

DATA BOOK

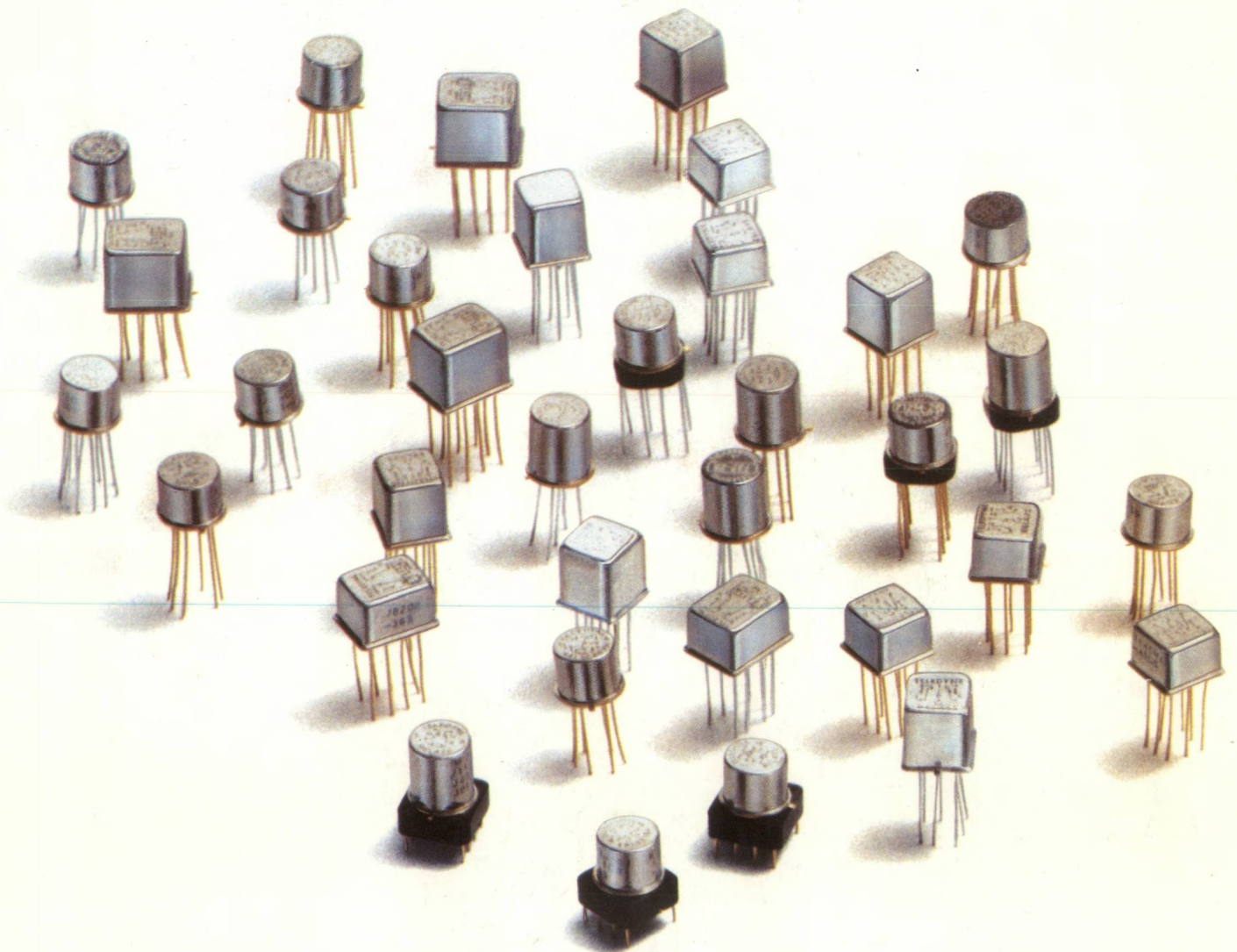

Featuring **TR²**™ Relays

Teledyne

Innovations in Switching Technology

The list of Teledyne innovations in switching technology continues to be the fastest growing and most extensive in the relay industry. Our list of relay innovations ranges from general purpose to sensitive to magnetic latching, from hybrids featuring diodes and transistors for TTL interfacing to units with internal FETS for direct CMOS operation, and include high temperature, high shock and high vibration relays for severe environmental uses. This Teledyne leadership in high quality design and production continues to extend across all switching applications: commercial and industrial as well as military and aerospace.

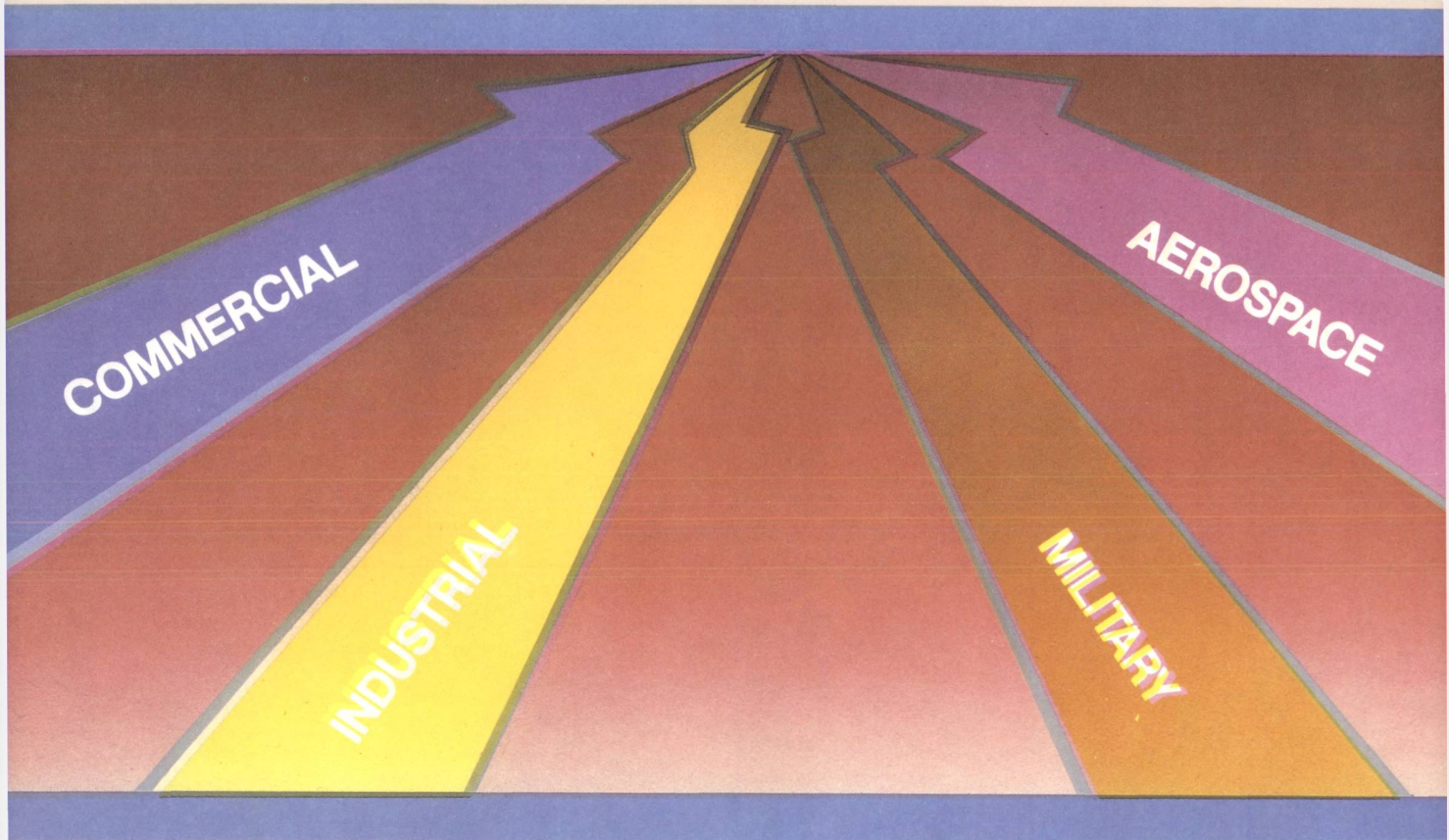

Commercial/Industrial

Commercial and industrial relays are manufactured using Teledyne-developed critical processes and controls. These devices are produced by blending specialized state of the art test and production capabilities of the main Teledyne plant in Hawthorne, California with international facilities. Thus, tight quality and management control is married to cost-effective production. The result is a line of highly reliable yet affordable relays.

Military/Aerospace

Military and aerospace products are assembled and produced in our 90,000 square foot, modern Hawthorne plant. This includes such critical operations as precision cleaning and vacuum baking in preparation for sealing, glass-to-metal seal production, noble metal plating and assembly in dedicated clean rooms.

Backing up these operations are an analytical laboratory staffed with metallurgical chemists, a radiation hardening program, NASA-based X-ray procedures, special ATE production systems, and Scanning Electron Microscope facilities.

100% electrical/environmental screening is also available for military applications, including MIL Spec and Hi Rel.

The Teledyne Quality Commitment

If all this emphasis on quality appears overly fastidious, it is. It has to be. We have built and enjoyed an unparalleled customer confidence over many years. But leaders can't rest on laurels. In order to maintain our confidence level as the industry leader, the customer has to be given assurance beyond question that any Teledyne relay is going to work — flawlessly.

FOREWARD

Once thought to be on the way to extinction when semiconductors were first invented, the venerable electromechanical relay is alive and thriving in an ultraminiature form invented and patented by Teledyne Relays.

Thirty years ago electromechanical relays were comparatively bulky devices that did not fit in with the new miniaturization of electronics that was being made possible by transistors and other new semiconductor devices. In fact, transistors themselves could function similar to relays, and for a while it looked as if all but very high power electromechanical relays might become obsolete. This has occurred to some extent for certain types of applications formerly dominated by relays. Though the role of relays has changed, the Teledyne T0-5 has kept pace with the semiconductor in meeting an ever increasing demand for reliable electromechanical switching necessary for use in many designs. In-process controls, and precision piece part fabrication techniques have been undergoing constant improvement over the years. The result is today's T0-5 relay, a relay that is as reliable as an equivalent solid state function; far smaller, and lower in cost.

THE MECHANICAL ADVANTAGE

Electromechanical relays do, however, offer a number of advantages that are difficult to duplicate with semiconductor devices. It was onto this stage that Teledyne entered some thirty years ago with the intent of miniaturizing relays and improving their performance and reliability to match that of the semiconductors that were beginning to dominate electronics. The company that Teledyne founded to carry out this development is known today as Teledyne Relays, and its T0-5 and Centigrid® relays are both unique and well-known throughout the world. They have become the industry standard.

FITTING IN WITH TRANSISTORS

Today, Teledyne Relays is one of the world's largest producers of miniature electromechanical relays. These products are widely used in aircraft avionics systems, communications equipment, satellites and space vehicles, and in a large number of military electronic programs.

ENTERING AN ULTRAMINIATURE WORLD

Putting a reliable, high performance electromechanical relay into the small confines of a T0-5 transistor case required an entirely new design and approach to manufacturing.

Conventional production machinery capable of automatically handling and assembling parts of microscopic dimensions did not exist when Teledyne Relays developed its T0-5 product line. Consequently, the company had to design, develop and engineer its own production machinery. One remarkable machine that is the result of this effort is capable of automatically performing 16 separate operations in the complete fabrication of the header assembly for the Centigrid® relay line.

Each of the parts on the T0-5 relay is fabricated to extremely close dimensional tolerances on highly specialized automated machinery, also designed and built by Teledyne Relays. Some of these parts are so minute — the armature hinge pins, for example — that it would take 3,600 of them to weigh one ounce. In spite of their size, these pins must be made to precise size with extremely fine surface finish so that the relay armature can pivot millions of times during its useful life without any chance of binding. Similarly, the insulated copper wire used to wind the electromagnet coil is approximately one-thousandth of an inch in diameter, or about one-third the thickness of a human hair.

Use of sophisticated production equipment, coupled with advanced cleaning and sealing techniques assure that T0-5 relay reliability standards are met on a consistent basis.

A FAMILY OF RELAYS

Teledyne Relays manufactures a number of types of T0-5 relays including a standard industrial/commercial line as well as high sensitivity types that can be actuated by a smaller input power. For even more sensitive response to low signal levels, Teledyne Relays offers transistor-driven models that incorporate a transistor chip inside the relay case. This further lowers input power requirements and conserves valuable space on the printed circuit boards, since a separate external transistor driver need not be used. Diodes are also frequently incorporated inside the cases of certain models for the suppression of voltage transients caused by switching the relay coil off, and for protection against polarity reversal, where these features are desirable.

Another specialized type of T0-5 relay is the latching type. Standard electromechanical relays require that the input circuit be energized as long as the output circuit is to be activated. A latching relay requires only a short electrical pulse to activate it from one state to another, where it remains until a second pulse changes it back to its original state. Latching relays are frequently used where it is important to conserve power since the input circuit need only be energized momentarily. The bi-stable operation makes them highly suitable for use where non-destructive memory is required.

T0-5 relays are made in standard industrial/commercial versions, in military versions that meet special military specifications, and in high reliability versions for critical aerospace and satellite applications. Special purpose models are also available for high shock, temperature and vibration environments.

THE CENTIGRID® LINE

Teledyne Relays' Centigrd® line utilizes the basic T0-5 relay mechanism, but is packaged in a low-profile square case that allows the terminal leads to be spaced on one-tenth inch centers. This design permits better compatibility with hole spacings on printed circuit boards and closer spacing of components.

HI-REL RELAYS

Teledyne's T0-5 and Centigrd® relays are used regularly in Hi-Rel space applications, in both manned and unmanned spacecraft. Our involvement in space dates back almost to the earliest days of the space program. Our T0-5 relays' small size, high force-to-mass ratio, tolerance for harsh radiation environments, coupled with low power consumption, make them ideal for spaceflight applications which have included missions to the edge of our solar system.

Teledyne regularly furnishes relays in accordance with specifications from NASA/Goddard, NASA/Jet Propulsion Lab, NASA/Marshall Spaceflight Center, the European Space Agency (ESA/SCC), Japan's NASDA, and numerous customer specifications which incorporate requirements of the proposed "S" level specification for T0-5 and Centigrd® type relays. Programs using these relays include:

Voyager, Insat, Goes, Intelsat, DSCS, Eutelsat, GPS, Mil-Star

Teledyne Relays offers Hi-Rel relays as a subset of its military product line. Our Hi-Rel program draws on the "inplace" engineering support, quality systems and production capability (which includes many automated processes) utilized in the high volume military and high-end commercial/industrial T0-5 relay production.

Special handling, additional processes and inspection steps, are employed in manufacturing and screening relays for Hi-Rel space applications. Each production lot of Hi-Rel relays receive 100% kit verification prior to kit release, 100% open electrical inspection, and 100% pre-cap visual inspection. In addition, a state-of-the-art small particle cleaning and inspection station with an in-line particle counter, using a Teledyne developed automated cleaning procedure, assures the ultimate in pre-cap cleanliness prior to sealing the completed relay.

Teledyne Relays' modern test lab facilities support our MIL-R-39016 and MIL-R-28776 qualification as well as performing the screening tests required for Hi-Rel applications. These include:

- **Asynchronous Miss Test • Particle Impact Noise Detection Test (PIND) • Shock**
- **Vibration — Sinusoidal and Random • Miss Test • Thermal Shock • Coil Continuity**
- **Acceleration • Radiographic Inspection • Load Banks for a Variety of Life Tests**

In addition, Teledyne has an in-house scanning electron microscope (SEM) to support performance of destructive physical analysis (DPA), and failure analysis.

The aerospace community was attracted to Teledyne's T0-5 relay technology because of its physical attributes, but it is the proven reliability and Teledyne Relay's dedication to supporting this demanding segment of the electronics business that has made Teledyne the industry standard for reliable relay switching in space for almost three decades. We welcome your inquiries regarding our relays for your spaceflight applications or other applications requiring the ultimate in switching innovation and reliability.

ANSWERING YOUR QUESTIONS

The Data Book you are holding contains detailed information for all of Teledyne Relays' T0-5 and Centigrd® relay product line. It should answer your questions regarding these devices. In the event it raises more questions, we welcome the opportunity to discuss them with you.

Our representative in your area has been selected for his demonstrated ability to assist with application problems. Feel free to contact him, or if you prefer, contact our home office to receive prompt factory applications engineering assistance. For prototype quantities, the nearest Teledyne Relay distributor is listed at the rear of the Data Book.

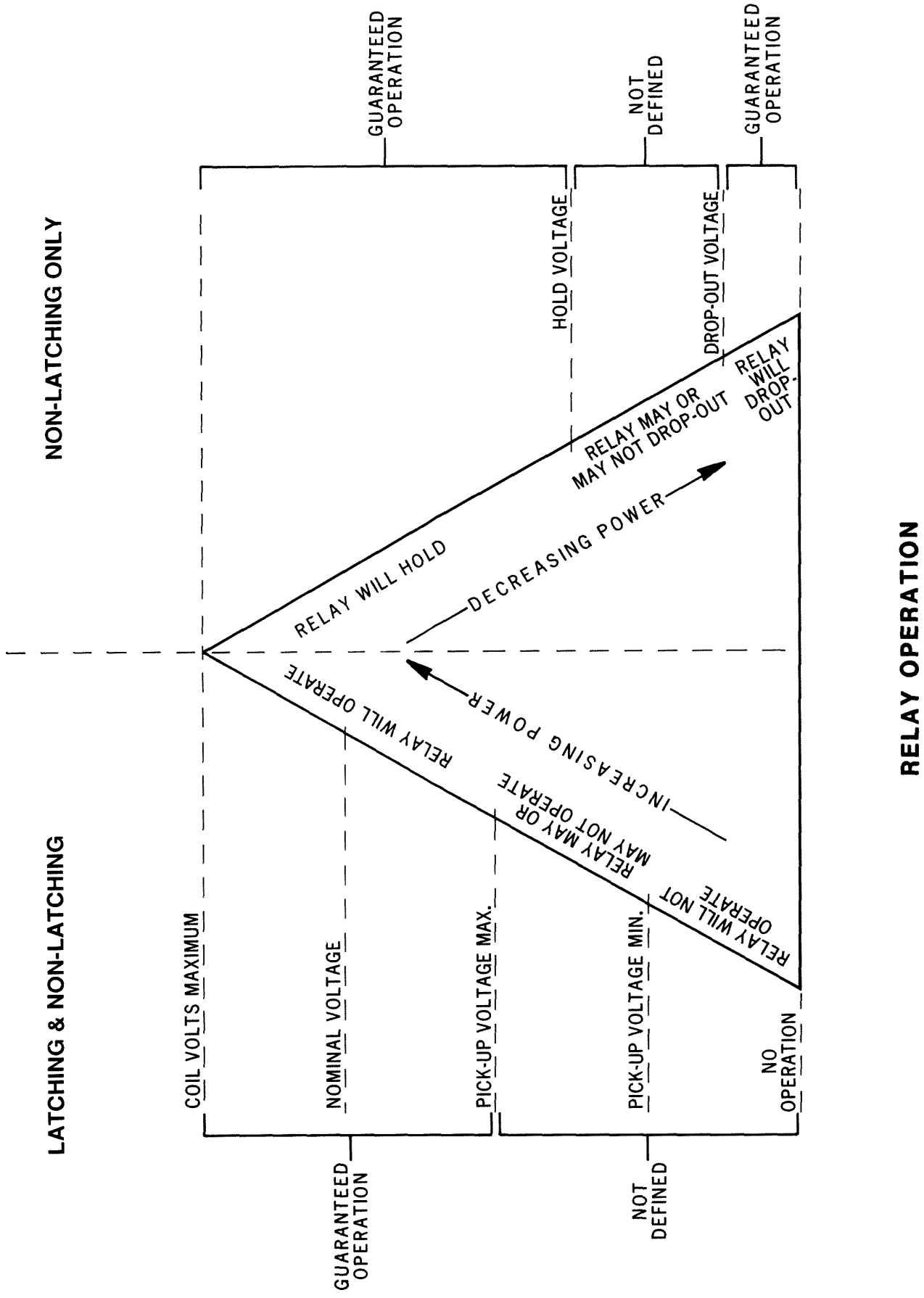

SCREENING AND RELIABILITY CHART

NOTES:

1. TELEDYNE WILL COMPLY WITH THE LATEST REVISION OF THE REFERENCED SPECIFICATIONS.
2. INSPECTION TEST (GROUP A) METHODS IN ACCORDANCE WITH MIL-R-28776 OR MIL-R-39016 AS APPLICABLE (NOTE 1) AND AS NOTED BELOW:

INSPECTION (Ref. MIL-R-39016)	INSPECTION (Ref. MIL-R-28776)	INSPECTION SAMPLE (100% unless otherwise noted)
<p>Subgroup 1 Level "A" only Screening, Internal Moisture Screening, Run-In (Room Temperature)</p> <p>Level "B" only Vibration (Sinusoidal) Screening, Internal Moisture Screening, Run-In (@ 125°C and -65°C)</p> <p>Subgroup 2 (Note 7) *Coil Resistance or Coil Current *Insulation Resistance *Dielectric Withstanding Voltage *Static Contact Resistance *Pickup, Hold and Dropout or Latch and Reset Voltage *Operate and Release Time *Contact Bounce (Level "A") Contact Stabilization Time (Level "B") *Coil Transient Suppression (for D and DD relays) *Diode Breakdown and Block Integrity Test (for DD relays, Note 6) Neutral Screen (for latching relays only)</p> <p>Subgroup 3 Solderability</p> <p>*Leak Test (Note 5) Visual and Mechanical Inspection</p>	<p>Subgroup 1 Level "A" only Screening, Internal Moisture Screening, Run-In (Room Temperature)</p> <p>Level "B" only Vibration (Sinusoidal) Screening, Internal Moisture Screening, Burn-In Screening, Run-In (@ 125°C and -65°C)</p> <p>Subgroup 2 (Note 7) *Coil Current *Insulation Resistance *Dielectric Withstanding Voltage [5 (60 Hz) cycles min.] *Static Contact Resistance *Pickup, Hold and Dropout Voltages *Turn-On Time and Turn-Off Time *Contact Bounce (Level "A") *Turn-On Current (for T relays) *Turn-On Voltage (for C relays) *Turn-Off Voltage Contact Stabilization Time (Level "B") *Coil Transient Suppression</p> <p>Subgroup 3 Solderability</p> <p>*Leak Test (Note 5) Visual and Mechanical Inspection</p>	<p>AQL 4.0 for Level "A" Internal Moisture only</p> <p>2 sample relays per Daily Solderability Inspection Lot</p> <p>2/lot for dimension and weight check</p>

*SCREENING PERFORMED WHEN NO RELIABILITY LEVEL IS SPECIFIED (TELEDYNE GENERIC PART NUMBER).

3. PERIODIC INSPECTIONS (GROUP B AND GROUP C) PER MIL-R-28776 OR MIL-R-39016 ARE NOT PERFORMED ON A REGULAR BASIS FOR RELIABILITY LEVEL A & B LEVEL RELAYS. FAILURE RATES ARE DERIVED FROM LIFE AND INTERMEDIATE CURRENT TESTS PERFORMED ON SIMILAR (JAN, A, B, AND CUSTOMER SCD) RELAY TYPES. VERIFICATION OF OTHER GROUP C REQUIREMENTS IS BY SIMILARITY TO JAN RELAY INSPECTIONS.

4.

RELIABILITY LEVEL	FAILURE RATE %/10,000 CYCLES
A	3.0
B	1.0

5. LEAK TEST FOR RELAYS WITH SPREADER PADS ARE PERFORMED IN ACCORDANCE WITH TELEDYNE RELAYS' INTERNAL PROCEDURES.
6. DIODE BREAKDOWN VOLTAGE TESTING IS PERFORMED DURING IN-PROCESS SCREENING OF THE DIODE.
7. TESTING SEQUENCE OPTIONAL.



TELEDYNE RELAYS DATA BOOK

Teledyne Relays Headquarters

12525 Daphne Ave.
Hawthorne, California 90250-3384
Telephone (213) 777-0077
TWX 910-321-4610
FAX 213-779-9161
EASYLINK 62952635
FSCM No. 11532

EASTERN REGIONAL OFFICE

Teledyne Relays
Cleveland Plaza
123 N. Union Avenue
Suite 306
Cranford, New Jersey 07016
(908) 272-0020
Easylink 62023363
FAX 908-272-7735

SOUTHEAST DISTRICT SALES OFFICE

Teledyne Relays
900 Fox Valley
Suite 206
Longwood, Florida 32779
(407) 682-9044
Easylink 62012265
FAX 407-682-7644

CENTRAL REGIONAL OFFICE

Teledyne Relays
11325 Pegasus Street
Suite W-201
Dallas, Texas 75238
(214) 348-0898
FAX 214-348-0915

NORTH CENTRAL DISTRICT SALES OFFICE

Teledyne Relays
290 Springfield Road
Suite 155
Bloomington, Illinois 60108
(708) 529-1060
Easylink 62023368
FAX 708-529-1120

WESTERN REGIONAL OFFICE

Teledyne Relays
5369 Camden Avenue
Suite 270
San Jose, California 95124
(408) 978-8898
FAX 408-978-8911

BELGIUM REGIONAL OFFICE

Teledyne Relays
181 Chaussee de la Hulpe
1170 Brussels
Belgium
(02) 673-99-88
TLX 84625881
Easylink 62912850
FAX 02-673-5847

GERMANY SALES OFFICE

Teledyne Relays
Abraham Lincoln Strasse 38-42
6200 Wiesbaden
Germany
0611-7636-0
TLX 4186846 TDYN D
FAX 0611-7636-155

FRANCE SALES OFFICE

Teledyne Relays
L'Arche Du Parc
738 Rue Yves Kermen
92658 Boulogne Billancourt Cedex
France
47-61-08-08
TLX 633005
Easylink 62912849
FAX 47-61-97-43

ENGLAND SALES OFFICE

Teledyne Relays
The Harlequin Centre
Southall Lane
Southall, Middlesex UB2 5NH
England
(081) 571-9596
TLX 935008
FAX 081-571-9439

JAPAN SALES OFFICE

Teledyne Relays
Taikoh No. 3 Bldg.
2-10-7 Shibuya, Shibuya-Ku
Tokyo 150
Japan
(3) 3797-6956
TLX 24335
FAX 3-3797-5255

TABLE OF CONTENTS

Section I **TR** Military Style Centigrid® and TO-5 Relays

Series	Description	Page
114	DPDT Centigrid®	8
116C	DPDT CMOS Compatible Centigrid®	11
122C	DPDT CMOS Compatible Magnetic Latching Centigrid®	14
134	DPDT Sensitive Centigrid®	17
136C	DPDT CMOS Compatible Sensitive Centigrid®	20
212	DPDT 2 Amp TO-5	23
411	SPDT TO-5	25
431	SPDT Sensitive TO-5	28
412	DPDT TO-5	31
432	DPDT Sensitive TO-5	35
421	SPDT Magnetic Latching	38
420/422	DPDT Magnetic Latching	41
400H	DPDT High Temperature	45
400K	DPDT High Shock	48
400V	DPDT High Vibration	51
RF120	DPDT Magnetic Latching R.F. Centigrid®	54
S114	DPDT Surface Mount Centigrid®	56
S134	DPDT Sensitive Surface Mount Centigrid®	59
	Special Packages	62
	Ground Pin Designator	64

Section II Military to Teledyne Qualified Part Number Cross Reference

Description	Page
MIL-R-28776	66
MIL-R-39016	68

Section III Commercial/Industrial Centigrid® and TO-5 Relays

Series	Description	Page
172	DPDT Centigrid®	81
S172	DPDT Surface Mount Centigrid®	83
712	DPDT TO-5	85
732	DPDT Sensitive TO-5	88
720/722	DPDT Magnetic Latching TO-5	91
RF170	DPDT Magnetic Latching R.F. Centigrid®	94

Section IV Appendix

Description	Page
Domestic Sales Representatives	97
Domestic Distributors	99
International Sales Representatives	101
International Distributors	102

Specifications published herein are subject to change without notice.

SECTION I



Military Style Centigrad® and TO-5 Relays

*Time Tested Relays/Time Tested Reliability

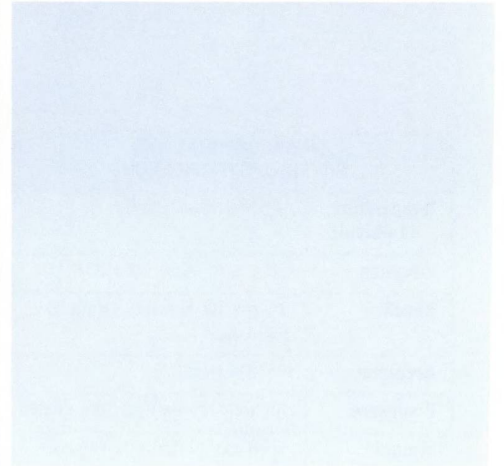
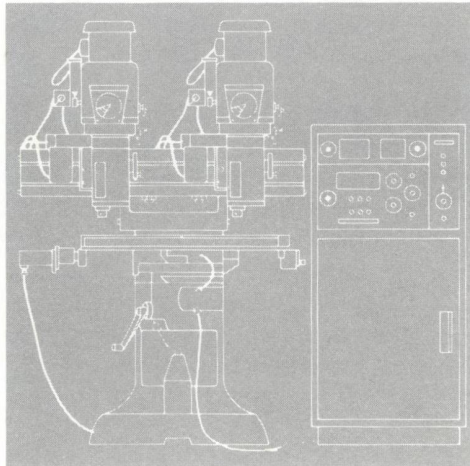
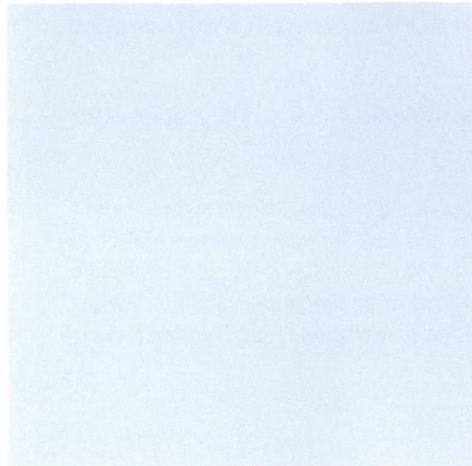
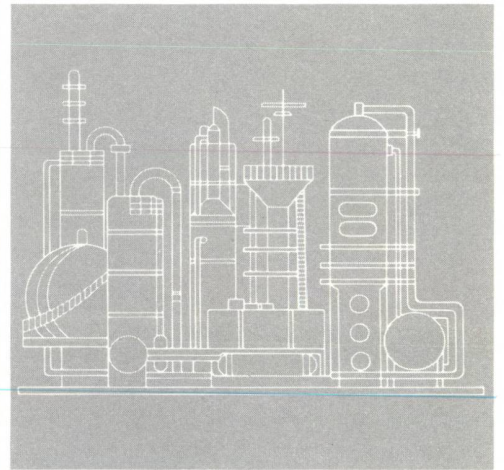
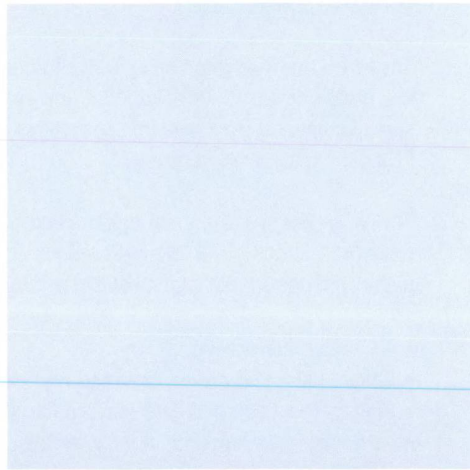
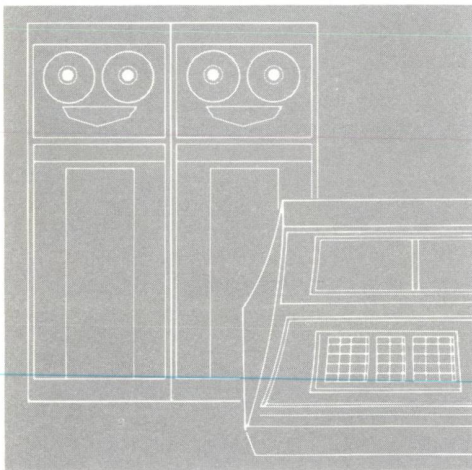
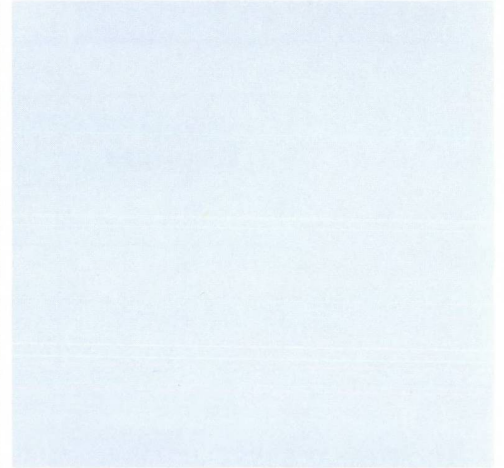
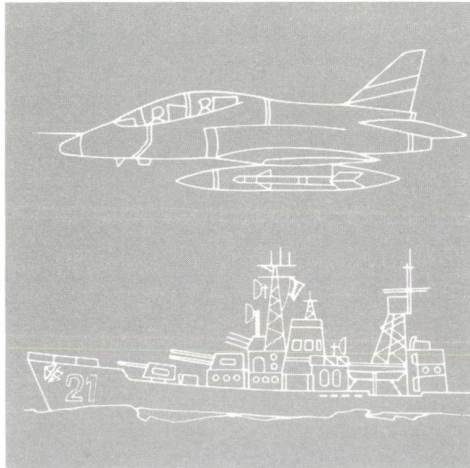
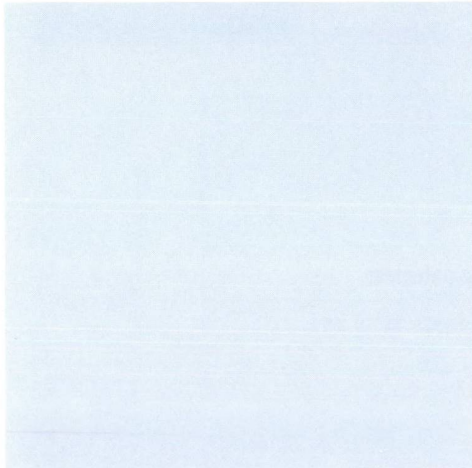

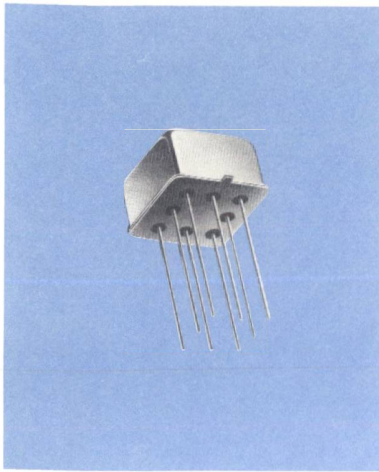

TELEDYNE RELAYS

CENTIGRID® MILITARY STYLE RELAY DPDT

SERIES
114



SERIES DESIGNATION	RELAY TYPE
114	DPDT basic relay
114D	DPDT relay with internal diode for coil transient suppression
114DD	DPDT relay with internal diodes for coil transient suppression and polarity reversal protection

INTERNAL CONSTRUCTION

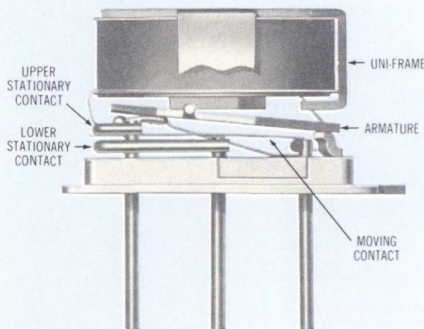

DESCRIPTION

The 114 series Centigrid® Relay is an ultraminiature, hermetically sealed, armature relay. Its low profile height (.275") and .100" grid spaced terminals, which precludes the need for spreader pads, make it ideal for applications where extreme packaging density and/or close PC board spacing are required.

The basic design and internal construction are similar to the Teledyne standard DPDT TO-5 relay (412 Series). The following unique construction features and manufacturing techniques provide overall high reliability and excellent resistance to environmental extremes:

- All welded construction.
- Unique uni-frame design providing high magnetic efficiency and mechanical rigidity.
- High force/mass ratios for resistance to shock and vibration.
- Advanced cleaning and sealing techniques provide maximum assurance of internal cleanliness.
- Precious metal alloy contact material with gold plating assures excellent high current and dry circuit switching capabilities.

The 114D and 114DD Series utilize internal discrete silicon diodes, with characteristics similar to 1N5315.

By virtue of its inherently low intercontact capacitance and contact circuit losses, the 114 relay has proven to be an excellent subminiature RF switch for frequency ranges well into the UHF spectrum. A typical RF application for the 114 relay is in hand held radio transceivers, wherein the combined features of good RF performance, small size, low coil power dissipation and high reliability make it the preferred relay for Transmit-Receive switching (see Figure 1).

ENVIRONMENTAL AND PHYSICAL SPECIFICATIONS

Temperature (Ambient)	-65°C to +125°C
Vibration	30 g's to 3000 Hz (Note 1)
Shock	75 g's for 6 msec. (Note 1) half-sine
Acceleration	75 g's (Note 1)
Enclosure	All welded, hermetically sealed
Weight	0.09 oz. (2.55 gms.) max.

GENERAL ELECTRICAL SPECIFICATIONS (-65°C to +125°C unless otherwise noted) (Notes 1 & 2)

Contact Arrangement	2 Form C (DPDT)	
Rated Duty	Continuous	
Contact Resistance	0.1 ohm max. before life; 0.2 ohm max. after life at 1A/28VDC (measured 1/8" from header)	
Contact Load Ratings (DC) (See Fig. 2 for other DC resistive voltage/current ratings)	Resistive: 1 Amp/28VDC Inductive: 200 mA/28VDC (320 mH) Lamp: 100 mA/28VDC Low Level: 10 to 50 μ A/10 to 50 mV	
Contact Load Ratings (AC)	Resistive: 250 mA/115VAC, 60 and 400Hz (Case not grounded) 100 mA/115VAC, 60 and 400Hz, (Case grounded)	
Contact Life Ratings	10,000,000 cycles (typical) at low level 1,000,000 cycles (typical) at 0.5A/28VDC resistive 100,000 cycles min. at all other loads specified above	
Contact Overload Rating	2A/28VDC Resistive (100 cycles min.)	
Contact Carry Rating	Contact factory	
Coil Operating Power	450 milliwatts typical at nominal rated voltage at 25°C	
Operate Time	2.0 msec. max. at nominal rated coil voltage	
Release Time	114 Series: 1.5 msec. max.	114D, 114DD Series: 4.0 msec. max.
Contact Bounce	1.5 msec. max.	
Intercontact Capacitance	0.4 pf. typical	
Insulation Resistance	10,000 megohms min. between mutually isolated terminals	
Dielectric Strength	Sea level: 500 VRMS/60 Hz.	70,000 ft.: 125 VRMS/60Hz.
Diode P.I.V. (114D, 114DD)	100 VDC, min.	
Negative Coil Transient (114D, 114DD)	1.0 VDC max.	

DETAILED ELECTRICAL SPECIFICATIONS (-65°C to +125°C unless otherwise noted) (Notes 1 & 2)

	GENERIC PART NUMBERS	➔	114-5	114-6	114-9	114-12	114-18	114-26
			114D-5 114DD-5	114D-6 114DD-6	114D-9 114DD-9	114D-12 114DD-12	114D-18 114DD-18	114D-26 114DD-26
Coil Voltage (VDC)	Nom.		5.0	6.0	9.0	12.0	18.0	26.5
	Max.		5.8	8.0	12.0	16.0	24.0	32.0
Coil Resistance (Ohms \pm 10% @ 25°C)	114, 114D		50	98	220	390	880	1560
	114DD (Note 3)		39	78	220	390	880	1560
Coil Current (mADC @ 25°C) (114DD Series)	Min.		93.2	58.3	33.0	25.6	17.5	14.8
	Max.		128.2	78.3	42.9	32.8	22.1	18.5
Pick-up Voltage (VDC, Max.)	114, 114D		3.5	4.5	6.8	9.0	13.5	18.0
	114DD		4.0	5.0	7.8	10.0	14.5	19.0
Drop-out Voltage (VDC)	114 & 114D	Min.	0.14	0.18	0.35	0.41	0.59	0.89
		Max.	2.3	3.2	4.9	6.5	10.0	13.0
	114DD	Min.	0.6	0.7	0.8	0.9	1.1	1.4
		Max.	2.8	3.4	5.3	6.5	10.0	13.0

PERFORMANCE CURVES (NOTE 2)

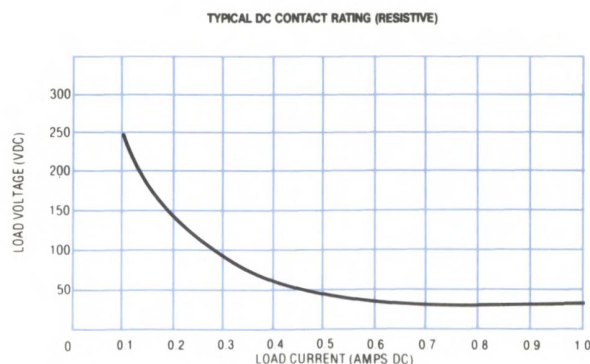
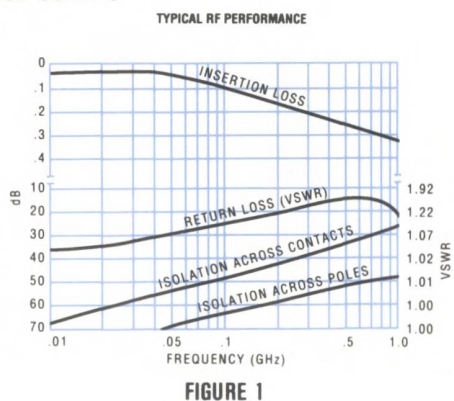

OUTLINE DIMENSIONS

CASE DETAIL

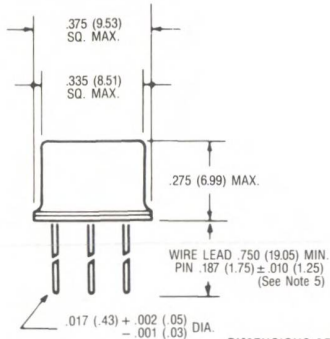

DIMENSIONS ARE SHOWN IN INCHES (MILLIMETERS)

TERMINAL LOCATIONS

(Viewed from Terminals. Numbers for Reference only)

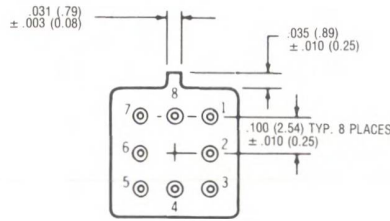

SCHEMATIC DIAGRAMS

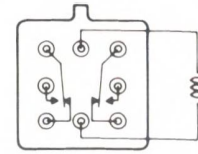

114

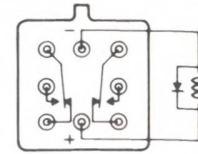

114D

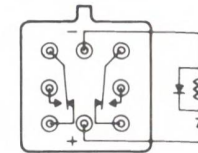

114DD

SCHEMATICS ARE VIEWED FROM TERMINALS

MOUNTING PAD

Relays can be supplied with a .014 in. thick mounting pad epoxied to the relay header. The pad (P/N 194-3) permits the relay to be spaced away from the mounting surface facilitating solder joint inspection. To order add M4 to Part Number. Example: 114M4-26.

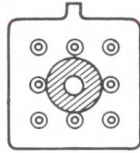

(TYPICAL INSTALLATION)

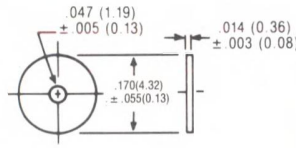

MOUNTING PAD

NOTES:

1. Max. height above mounting surface increased by 0.025 in. (0.64mm).
2. Material: Polyester film
3. Add 0.01 ohm to contact resistance with mounting pad.

MILITARY P/N TO TELEDYNE P/N COMPARISON CHART

REFERENCE M39016/17, /18, /19

SLASH & DASH	TELEDYNE PART NO.*	SLASH & DASH	TELEDYNE PART NO.*	SLASH & DASH	TELEDYNE PART NO.*	SLASH & DASH	TELEDYNE PART NO.*	SLASH & DASH	TELEDYNE PART NO.*	SLASH & DASH	TELEDYNE PART NO.*
/17-025	114S-5	/17-040	114M4-12	/18-025	114DS-5	/18-040	114DM4-12	/19-025	114DDS-5	/19-040	114DDM4-12
-026	-6	-041	-18	-026	-6	-041	-18	-026	-6	-041	-18
-027	-9	-042	-26	-027	-9	-042	-26	-027	-9	-042	-26
-028	-12	/17-043	114Z-5	-028	-12	/18-043	114DZ-5	-028	-12	/19-043	114DDZ-5
-029	-18	-044	-6	-029	-18	-044	-6	-029	-18	-044	-6
-030	-26	-045	-9	-030	-26	-045	-9	-030	-26	-045	-9
/17-031	114-5	-046	-12	/18-031	114D-5	-046	-12	/19-031	114DD-5	-046	-12
-032	-6	-047	-18	-032	-6	-047	-18	-032	-6	-047	-18
-033	-9	-048	-26	-033	-9	-048	-26	-033	-9	-048	-26
-034	-12	/17-049	114ZM4-5	-034	-12	/18-049	114DZM4-5	-034	-12	/19-049	114DDZM4-5
-035	-18	-050	-6	-035	-18	-050	-6	-035	-18	-050	-6
-036	-26	-051	-9	-036	-26	-051	-9	-036	-26	-051	-9
-037	114M4-5	-052	-12	/18-037	114DM4-5	-052	-12	/19-037	114DDM4-5	-052	-12
-038	-6	-053	-18	-038	-6	-053	-18	-038	-6	-053	-18
-039	-9	-054	-26	-039	-9	-054	-26	-039	-9	-054	-26

* Add reliability level designator A or B. See Teledyne Relays part numbering system and screening and reliability chart (Note 4).

NOTES:

1. Relays generally conform to the processes, performance and test requirements of MIL-R-39016. Minor variations in procedures, which do not effect performance or reliability, may be incorporated at the manufacturer's discretion.
2. Performance Characteristics are subject to change beyond those allowed by the applicable Military specification when testing is performed beyond the MIL-R-39016 rated life. "Typical" characteristics are based on available data and are best estimates. No on-going verification tests are performed.
3. For reference only. Coil resistance not directly measurable at relay terminals due to internal series semiconductor. 114DD only.
4. Screened hi-rel versions available on special order. Contact factory.
5. Unless otherwise specified, relays are supplied with standard 0.75" (19.05mm) minimum leads. For optional 0.187" (4.75mm) pin versions, add "S" to part number (i.e., 114-5 becomes 114S-5, 114D-5 becomes 114DS-5, etc.).

RELIABILITY LEVEL	FAILURE RATE %/10,000 CYCLES
A	3.0
B	1.0

TELEDYNE PART NUMBERING SYSTEM FOR MIL-STYLE RELAYS

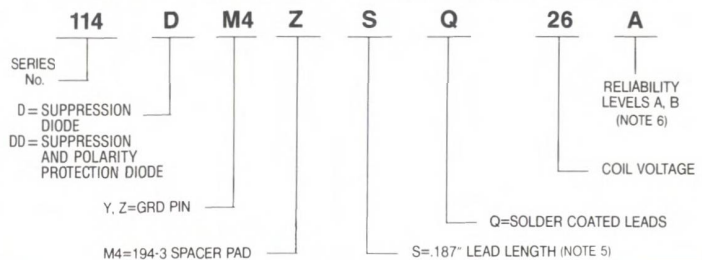

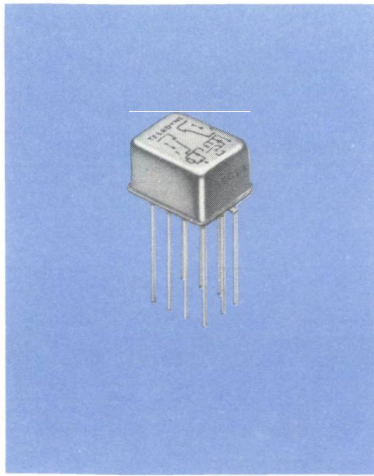

TELEDYNE RELAYS

CENTIGRID® MILITARY STYLE RELAY

DPDT

CMOS COMPATIBLE

SERIES
116C



SERIES DESIGNATION	RELAY TYPE
116C	DPDT general purpose relay with internal power MOS FET driver and diode coil suppression

INTERNAL CONSTRUCTION

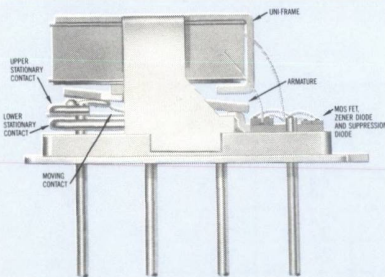

DESCRIPTION

The 116C Centigrid® relay is an ultraminiature, hermetically sealed, armature relay capable of being directly driven by most IC logic families. Its low profile height and .100" grid spaced terminals, which precludes the need for spreader pads, make it ideal for applications where extreme packaging density and/or close PC board spacing are required.

The basic concept and internal structure are similar to the Teledyne DPDT TO-5 relay (412 Series). Unique construction features and manufacturing techniques provide overall high reliability and excellent resistance to environmental extremes:

- All welded construction.
- Unique uni-frame design providing high magnetic efficiency and mechanical rigidity.
- High force/mass ratios for resistance to shock and vibration.
- Advanced cleaning and sealing techniques provide maximum assurance of internal cleanliness.
- Precious metal alloy contact material with gold plating assures excellent high current and dry circuit switching capabilities.

By virtue of its inherently low intercontact capacitance and contact circuit losses, the Centigrid® relay has proven to be an excellent subminiature RF switch for frequency ranges well into the UHF spectrum. A typical RF application for the Centigrid® relay is in hand held radio transceivers, wherein the combined features of good RF performance, small size, low coil power dissipation and high reliability make it the preferred relay for Transmit-Receive switching (see Figure 1).

The 116C Series utilizes an internal silicon diode for coil suppression, a Zener diode to protect the MOSFET gate input, and an N-channel enhancement mode MOSFET chip which enables direct relay interfacing with most Microprocessor and IC logic families (CMOS, TTL and MOS).

ENVIRONMENTAL AND PHYSICAL SPECIFICATIONS	
Temperature (Ambient)	-65°C to +125°C
Vibration	30 g's to 3000 Hz (Note 1)
Shock	75 g's for 6 msec. (Note 1) half-sine
Acceleration	75 g's (Note 1)
Enclosure	All welded, hermetically sealed
Weight	0.11 oz. (3.12 gms) max.

SERIES 116C

GENERAL ELECTRICAL SPECIFICATIONS (-65°C to +125°C unless otherwise noted) (Notes 1 & 2)

Contact Arrangement	2 Form C (DPDT)	
Rated Duty	Continuous	
Contact Resistance	0.1 ohm max. before life; 0.2 ohm max. after life at 1A/28VDC (measured 1/8" from header)	
Contact Load Ratings (DC) (See Fig. 2 for other DC resistive voltage/current ratings)	Resistive: 1 Amp/28VDC Inductive: 200 mA/28VDC (320 mH) Lamp: 100 mA/28VDC Low Level: 10 to 50 μ A/10 to 50 mV	
Contact Load Ratings (AC)	Resistive: 250 mA/115VAC, 60 and 400 Hz (Case not grounded) 100 mA/115VAC, 60 and 400 Hz, (Case grounded)	
Contact Life Ratings	10,000,000 cycles (typical) at low level 1,000,000 cycles (typical) at 0.5A/28VDC resistive 100,000 cycles min. at all other loads specified above	
Contact Overload Rating	2A/28VDC Resistive (100 cycles min.)	
Contact Carry Rating	Contact factory	
Operate Time	2.5 msec. max. at nominal rated coil voltage	
Release Time	4.0 msec. max.	
Contact Bounce	1.5 msec. max.	
Intercontact Capacitance	0.4 pf. typical	
Insulation Resistance	10,000 megohms min. between mutually isolated terminals (Note 3)	
Dielectric Strength	Sea level: 500 VRMS/60 Hz.	70,000 ft.: 125 VRMS/60 Hz. (Note 3)
Diode P.I.V. (VDC)	100 min.	
Negative Coil Transient (VDC)	1.0 max.	
Zener Voltage (VDC)	17 min. to 23 max.	
Zener Leakage Current (μA @ 15.2 VDC)	2.5 max.	
Power FET Characteristics	Gate Voltage to Turn Off (VDC, Max.)	0.5
-65°C to + 125°C	Gate Voltage to Turn On (VDC, Min.)	3.8 (Note 5)
	Drain-Source Voltage (VDC, Max.)	55

DETAILED ELECTRICAL SPECIFICATIONS (-65°C to +125°C unless otherwise specified) (Notes 1 & 2)

CHARACTERISTICS	GENERIC PART NUMBERS	GENERIC PART NUMBERS					
		116C-5	116C-6	116C-9	116C-12	116C-18	116C-26
Coil Voltage (VDC)	Nom.	5.0	6.0	9.0	12.0	18.0	26.5
	Max.	5.6	8.0	12.0	16.0	24.0	32.0
Coil Current (mA @ 25°C)	Max.	132.3	83.9	47.1	36.1	24.1	19.9
	Min.	96.5	60.3	33.1	24.9	16.1	12.9
Nominal Coil Operating Power @25°C (Milliwatts)		641	462	368	369	368	450
Pick-up Voltage (VDC) (Note 5)	Max.	4.0	4.9	7.3	9.8	14.6	19.5
Drop-out Voltage (VDC) (Note 5)	Min.	0.13	0.18	0.27	0.36	0.54	0.72
	Max.	2.3	3.2	4.9	6.5	9.8	13.0

PERFORMANCE CURVES (NOTE 2)

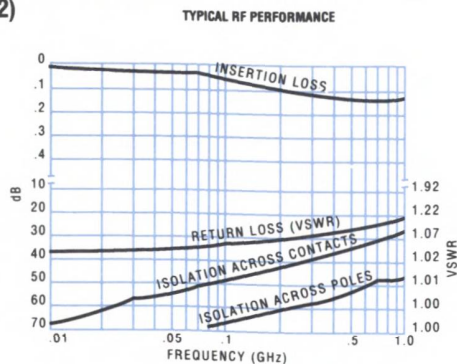

FIGURE 1

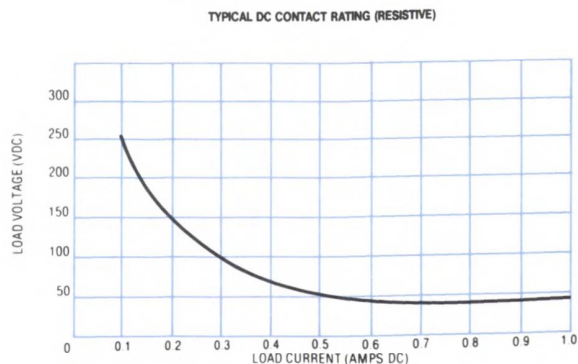
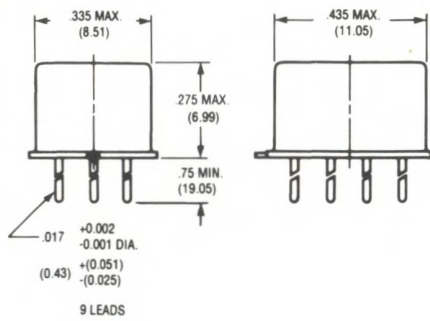

FIGURE 2

**OUTLINE DIMENSIONS
CASE DETAIL**



TERMINAL LOCATIONS

(Viewed from Terminals, Numbers for Reference only)

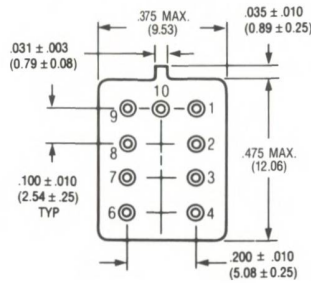

DIMENSIONS ARE SHOWN IN INCHES (MILLIMETERS)

SCHEMATIC DIAGRAM

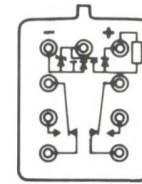

PIN 1: + SUPPLY
PIN 9: - SUPPLY
PIN 10: GATE

SCHEMATIC IS VIEWED FROM TERMINALS

MOUNTING PAD

Relays can be supplied with a .014 in. thick mounting pad epoxied to the relay header. The pad (P/N 194-19) permits the relay to be spaced away from the mounting surface facilitating solder joint inspection. To order add M9 to Part Number. Example: 116CM9-26.

- NOTES:**
1. Max. height above mounting surface increased by 0.025 in. (0.64mm)
 2. Material: Polyester film
 3. Add 0.01 ohm to contact resistance with mounting pad.

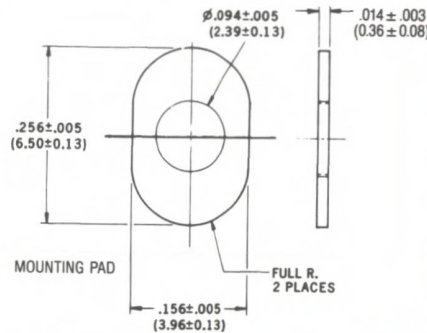
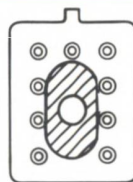

TYPICAL CMOS INTERFACE CIRCUIT

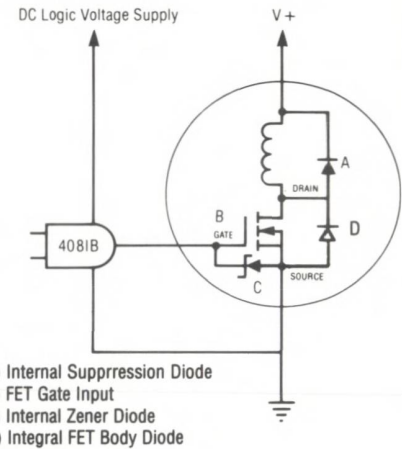

MILITARY P/N TO TELEDYNE P/N COMPARISON CHART REFERENCE M28776/6

SLASH & DASH	TELEDYNE PART NO.*	SLASH & DASH	TELEDYNE PART NO.*
/6-001	116C-5	/6-007	116CM9-5
-002	-6	-008	-6
-003	-9	-009	-9
-004	-12	-010	-12
-005	-18	-011	-18
-006	-26	-012	-26

*Add reliability level designator A or B. See Teledyne Relays part numbering system and screening and reliability chart (Note 4).

NOTES:

1. Relays generally conform to the processes, performance and test requirements of MIL-R-28776. Minor variations in procedures, which do not effect performance or reliability, may be incorporated at the manufacturer's discretion.
2. Performance Characteristics are subject to change beyond those allowed by the Military specification when testing is performed beyond the MIL-R-28776 rated life. "Typical" characteristics are based on available data and are best estimates. No on-going verification tests are performed.
3. Pins 9 and 10 must be shorted when testing for insulation resistance and Dielectric Strength.
4. Screened hi-rel versions available on special order. Contact factory.
5. Maximum rated gate voltage = 15VDC.

RELIABILITY LEVEL	FAILURE RATE %/10,000 CYCLES
A	3.0
B	1.0

TELEDYNE PART NUMBERING SYSTEM FOR MIL-STYLE RELAYS

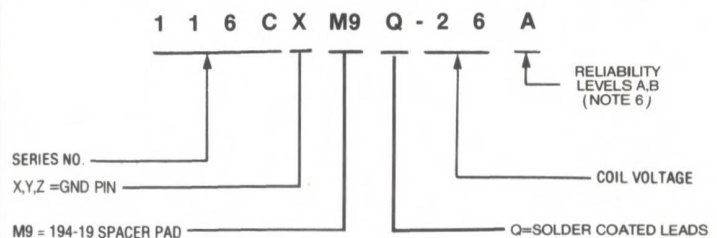

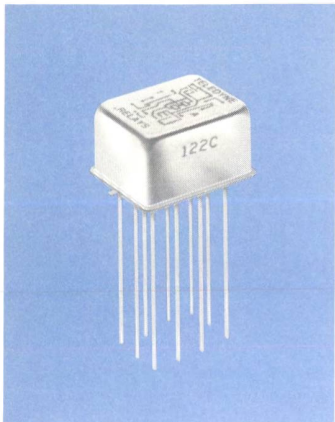

TELEDYNE RELAYS

CENTIGRID® MAGNETIC LATCHING MILITARY STYLE RELAY DPDT CMOS COMPATIBLE

SERIES
122C

SERIES DESIGNATION	RELAY TYPE
122C	DPDT general purpose magnetic latching relay with internal power MOSFET driver and diode coil transient suppression

DESCRIPTION

The 122C Centigrad® magnetic latching relay is an ultraminiature, hermetically sealed, armature relay capable of being directly driven by most IC logic families. Its low profile height and .100" grid spaced terminals, which precludes the need for spreader pads, make it ideal for applications where extreme packaging density and/or close PC board spacing are required.

The basic concept and internal structure are similar to the Teledyne TO-5 422 relay series. The 122C is capable of meeting the requirements of MIL-R-28776 and MIL-R-39016 as applicable. Unique construction features and manufacturing techniques provide overall high reliability and excellent resistance to environmental extremes:

- All welded construction.
- Unique uni-frame design providing high magnetic efficiency and mechanical rigidity.
- High force/mass ratios to withstand shock and vibration.
- Advanced cleaning and sealing techniques provide maximum assurance of internal cleanliness.
- Precious metal alloy contact material with gold plating assures excellent high current and dry circuit switching capabilities.

The 122C Series utilizes internal silicon diodes for coil suppression, Zener diodes to protect the MOSFET gate inputs, and N-channel enhancement-mode MOSFET chips, which enable direct relay interfacing with most microprocessor and IC logic families (CMOS, TTL and MOS).

The 122C magnetic latching relay is ideally suited for applications where power dissipation must be minimized. The relays can be operated with a short duration pulse: after contacts have transferred, no holding power is required.

The magnetic latching feature of the 122C Series provide a "memory" capability, since the relays will not reset upon removal of power.

By virtue of its inherently low intercontact capacitance and contact circuit losses, the Centigrad® relay has proven to be an excellent subminiature RF switch for frequency ranges well into the UHF spectrum. A typical RF application for the Centigrad® relay is in hand held radio transceivers, wherein the combined features of good RF performance, small size, low coil power dissipation, and high reliability make it the preferred relay for transmit-receive switching (see Figure 1).

PRINCIPLE OF OPERATION

Energizing Coil B produces a magnetic field opposing the holding flux of the permanent magnet in Circuit B. As this net holding force decreases, the attractive force in the air gap of Circuit A, which also results from the flux of the permanent magnet, becomes great enough to break the armature free of Core B, and snap it into a closed position against Core A. The armature then remains in this position upon removal of energy from Coil B, but will snap back to position B upon energizing Coil A. Since operation depends upon cancellation of a magnetic field, it is necessary to apply the correct polarity to the relay coils as indicated on the relay schematic.

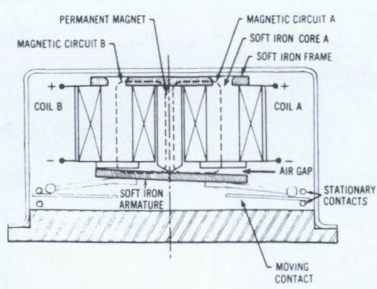

When latching relays are installed in equipment, the latch and reset coils should not be pulsed simultaneously. Coils should not be pulsed with less than the maximum set/reset voltage and the pulse width should be a minimum of three times the specified operate time of the relay. If these conditions are not followed, it is possible for the relay to be in the magnetically neutral position.

ENVIRONMENTAL AND PHYSICAL SPECIFICATIONS	
Temperature (Ambient)	-65°C to +125°C
Vibration	30 g's to 3000 Hz (Note 3)
Shock	100 g's for 6 msec. (Note 3) half-sine
Acceleration	75 g's (Note 3)
Enclosure	All welded, hermetically sealed
Weight	0.10 oz. (2.75 gms.) max.

GENERAL ELECTRICAL SPECIFICATIONS (-65°C to +125°C unless otherwise noted) (NOTES 1 AND 2)

Contact Arrangement		2 Form C (DPDT)
Rated Duty		Continuous
Contact Resistance		0.125 ohm max. before life; 0.225 ohm max. after life at 1A/28VDC, (measured 1/8" from header)
Contact Load Ratings (DC) (See Fig. 2 for other DC resistive voltage/current ratings)		Resistive: 1 Amp/28VDC Inductive: 200 mA/28VDC (320 mH) Lamp: 100 mA/28VDC Low Level: 10 to 50 μ A/10 to 50 mV
Contact Load Ratings (AC)		Resistive: 250 mA/115VAC, 60 and 400 Hz (Case not grounded) 100 mA/115VAC, 60 and 400 Hz, (Case grounded)
Contact Life Ratings		10,000,000 cycles (typical) at low level 1,000,000 cycles (typical) at 0.5A/28VDC resistive 100,000 cycles min. at all other loads specified above
Contact Overload Rating		2 A/28VDC Resistive (100 cycles min.)
Contact Carry Rating		Contact factory
Operate Time		1.5 msec. max. at nominal rated coil voltage at 25°C
Minimum Operate Pulse		4.5 msec. at nominal voltage
Contact Bounce		2.0 msec. max.
Intercontact Capacitance		0.4 pf. typical
Insulation Resistance		10,000 megohms min. between mutually isolated terminals (Note 5)
Dielectric Strength		Sea level: 500 VRMS/60 Hz 70,000 ft.: 125 VRMS/60 Hz (Note 5)
Negative Coil Transient (VDC)		1.0 max.
Diode P.I.V. (VDC)		100 min.
Zener Voltage (VDC)		17 min. to 23 max.
Zener Leakage Current @ 15.2 VDC (μA)		2.5 max.
Power FET Characteristics -65°C to +125°C	Gate Voltage to Turn Off (Vdc)	0.5 max.
	Gate Voltage to Turn On (VDC)	3.8 min. (Note 7)
	Drain-Source Voltage (VDC)	55 max.

DETAILED ELECTRICAL SPECIFICATIONS (-65°C to +125°C unless otherwise noted) (NOTE 2)

	GENERIC PART NUMBERS (NOTE 4)	122C-5	122C-6	122C-9	122C-12	122C-18	122C-26
		Coil Voltage (VDC)	Nom.	5.0	6.0	9.0	12.0
	Max.	5.6	8.0	12.0	16.0	24.0	32.0
Coil Current (mADC @ 25°C) (Note 6)	Max.	114.9	57.0	37.2	27.8	18.2	15.2
	Min.	82.2	41.6	27.4	20.5	13.7	11.4
Coil Operating Power @ 25°C and Rated Voltage (mW)	Nom.	505	296	288	287	286	351
Latch and Reset Voltage (VDC) (Note 7)	Max.	3.5	4.5	6.8	9.0	13.5	18.0

PERFORMANCE CURVES (NOTE 1)

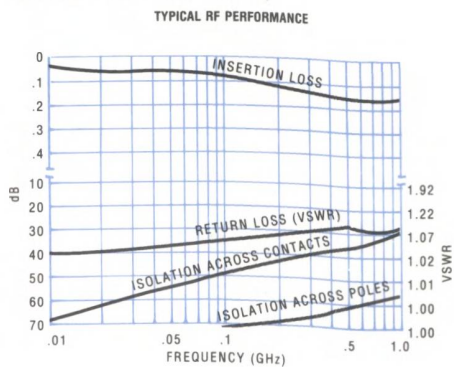

FIGURE 1

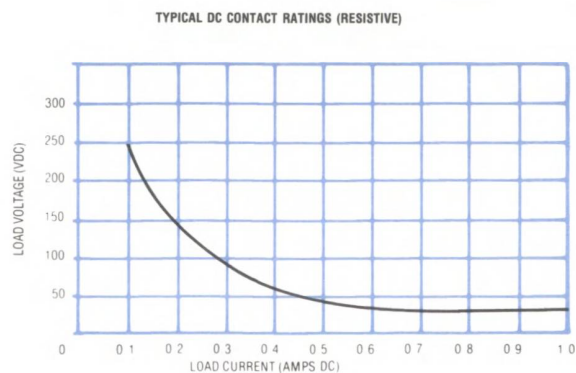
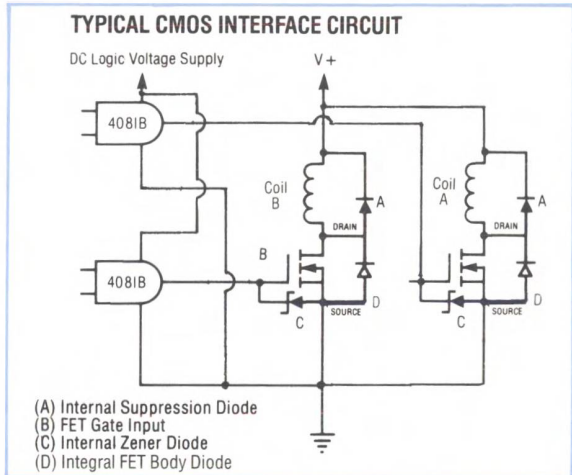
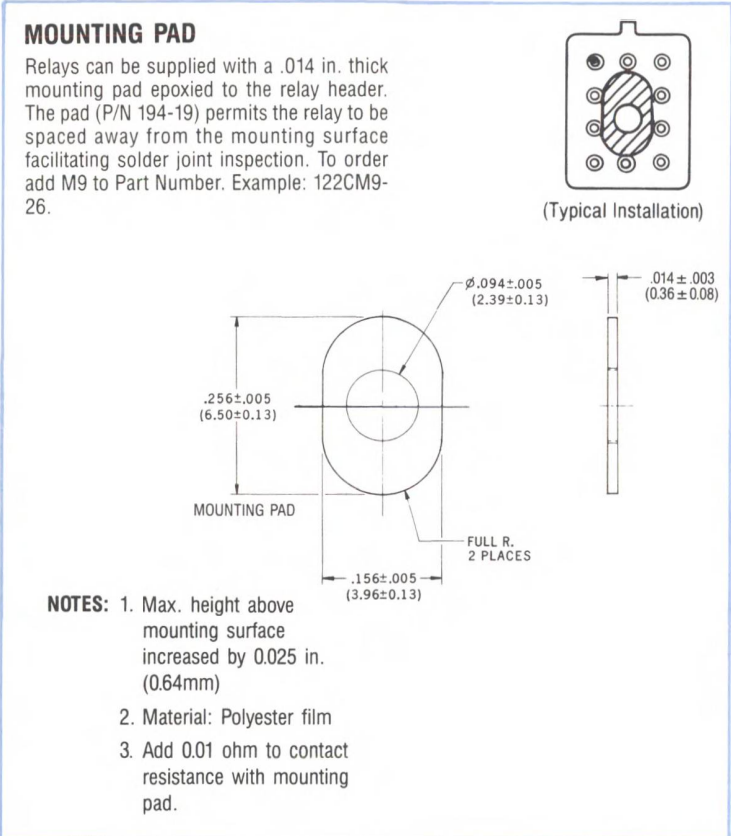
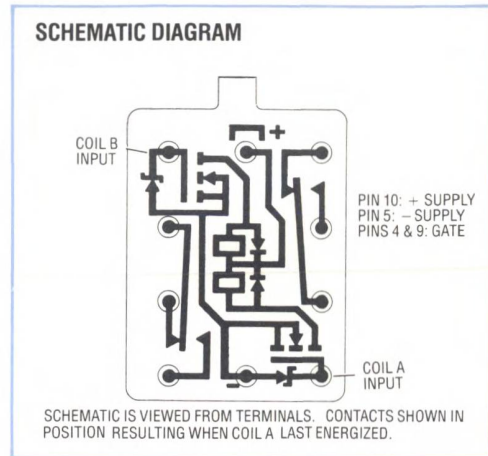
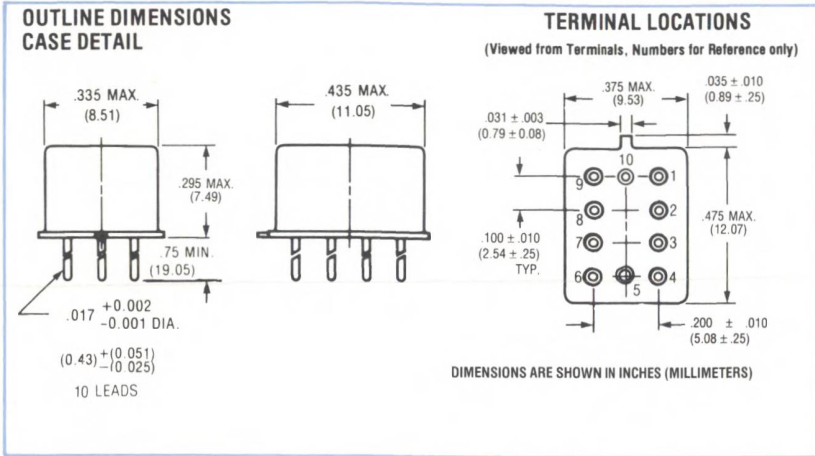
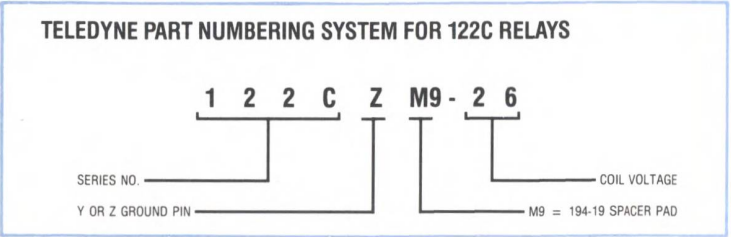

FIGURE 2

SERIES 122C



- ### NOTES
1. Characteristics shown as "typical" are based on available data and are best estimates. No on-going verification tests are performed.
 2. Characteristics are subject to change after life.
 3. Relays will exhibit no contact chatter in excess of 10 μsec or transfer in excess of 1 μsec.
 4. Screened hi-rel versions available on special order. Contact factory.
 5. Pins 4, 5 and 9 must be shorted when tested for Insulation Resistance and Dielectric Strength.
 6. Measured for 5 sec. maximum. Includes allowance for "on" resistance of MOSFET.
 7. Maximum rated gate voltage = 15 VDC.



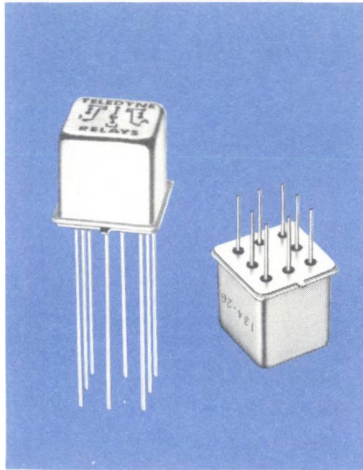

TELEDYNE RELAYS

CENTIGRID® MILITARY STYLE RELAY SENSITIVE DPDT

SERIES
134



SERIES DESIGNATION	RELAY TYPE
134	DPDT basic relay
134D	DPDT relay with internal diode for coil transient suppression
134DD	DPDT relay with internal diodes for coil transient suppression and polarity reversal protection

INTERNAL CONSTRUCTION

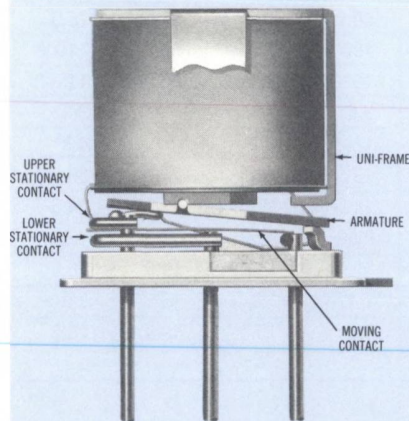

DESCRIPTION

The sensitive Centigrid® relay retains the same features as the standard Centigrid® with only a minimal increase in profile height (.375 in.). It provides a .100 in. grid spaced terminal pattern which precludes the need for spreader pads and, together with the low profile, is ideal for applications where high packaging density is important.

Unique construction features and manufacturing techniques provide excellent resistance to environmental extremes and overall high reliability.

- All welded construction.
- Unique uni-frame design providing high magnetic efficiency and mechanical rigidity.
- High force/mass ratios for resistance to shock and vibration.
- Advanced cleaning and sealing techniques provide maximum assurance of internal cleanliness.
- Precious metal alloy contact material with gold plating assures excellent high current and dry circuit switching capabilities.

The 134D and 134DD Series utilize internal discrete silicon diodes, with characteristics similar to 1N5315.

The sensitive Centigrid® relay features exceptionally high coil resistance thus providing for extremely low operating power (200 mw typical). The advantages of reduced heat dissipation and power supply demands are obvious.

By virtue of its inherently low intercontact capacitance and contact circuit losses, the 134 relay has proven to be an excellent subminiature RF switch for frequency ranges well into the UHF spectrum. A typical RF application for the Centigrid® relay is in hand held radio transceivers, wherein the combined features of good RF performance, small size, low coil power dissipation and high reliability make it the preferred relay for Transmit-Receive switching (see Figure 1).

ENVIRONMENTAL AND PHYSICAL SPECIFICATIONS

Temperature (Ambient)	-65°C to +125°C
Vibration	30 g's to 3000 Hz (Note 1)
Shock	75 g's for 6 msec. (Note 1) half-sine
Acceleration	75 g's (Note 1)
Enclosure	All welded, hermetically sealed
Weight	0.15 oz. (4.3 gms.) max.

SERIES 134

GENERAL ELECTRICAL SPECIFICATIONS (-65°C to +125°C unless otherwise noted) (Notes 1 & 2)

Contact Arrangement	2 Form C (DPDT)	
Rated Duty	Continuous	
Contact Resistance	0.1 ohm max. before life; 0.2 ohm max. after life at 1A/28VDC, (measured 1/8" from header)	
Contact Load Ratings (DC) (See Fig. 2 for other DC resistive voltage/current ratings)	Resistive: 1 Amp/28VDC Inductive: 200 mA/28VDC (320 mH) Lamp: 100 mA/28VDC Low Level: 10 to 50 μ A/10 to 50 mV	
Contact Load Ratings (AC)	Resistive: 250 mA/115VAC, 60 and 400Hz (Case not grounded) 100 mA/115VAC, 60 and 400 Hz (Case grounded)	
Contact Life Ratings	10,000,000 cycles (typical) at low level 1,000,000 cycles (typical) at 0.5A/28VDC resistive 100,000 cycles min. at all other loads specified above	
Contact Overload Rating	2A/28VDC Resistive (100 cycles min.)	
Contact Carry Rating	Contact factory	
Coil Operating Power	200 milliwatts typical at nominal rated voltage at 25°C	
Operate Time	4.0 msec. max. at nominal rated coil voltage	
Release Time	134 Series 2.0 msec. max.	134D, 134DD Series: 7.5 msec. max.
Contact Bounce	1.5 msec. max.	
Intercontact Capacitance	0.4 pf. typical	
Insulation Resistance	10,000 megohms min. between mutually isolated terminals	
Dielectric Strength	Sea level: 500 VRMS/60 Hz.	70,000 ft.: 125 VRMS/60Hz.
Diode P.I.V. (134D, 134DD)	100 VDC, min.	
Negative Coil Transient (134D, 134DD)	1.0 VDC max.	

DETAILED ELECTRICAL SPECIFICATIONS (-65°C to +125°C unless otherwise noted) (Notes 1 & 2)

	GENERIC PART NUMBERS	➔	134-5	134-6	134-9	134-12	134-18	134-26	134-36	134-48
			134D-5	134D-6	134D-9	134D-12	134D-18	134D-26	134D-36	134D-48
Coil Voltage (VDC)	Nom.		5.0	6.0	9.0	12.0	18.0	26.5	36.0	48.0
	Max.		7.5	10.0	15.0	20.0	30.0	40.0	57.0	75.0
Coil Resistance (Ohms \pm 10% @ 25°C)	134, 134D		100	200	400	800	1600	3200	6500	11000
	134DD (Note 3)		64	125	400	800	1600	3200	6500	11000
Coil Current (mADC @ 25°C) (134DD Series only)	Min.		56.8	36.3	18.1	12.5	9.6	7.2	4.9	3.9
	Max.		78.1	48.9	23.6	16.0	12.2	9.0	6.1	4.8
Pick-up Voltage (VDC, Max.)	134, 134D		3.5	4.5	6.8	9.0	13.5	18.0	27.0	36.0
	134DD		3.7	4.8	8.0	11.0	14.5	19.0	27.2	34.8
Drop-Out Voltage (VDC)	134 & 134D	Min.	0.12	0.18	0.35	0.41	0.59	0.89	1.25	1.60
		Max.	2.5	3.2	4.9	6.5	10.0	13.0	19.0	26.0
	134DD	Min.	0.7	0.8	0.9	1.0	1.1	1.3	1.7	2.0
		Max.	2.6	3.0	4.5	5.8	9.0	13.0	19.0	26.0

PERFORMANCE CURVES (NOTE 2)

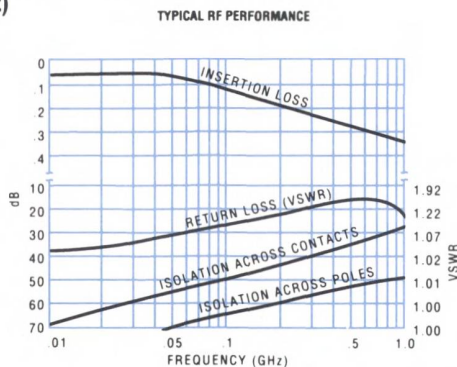

FIGURE 1

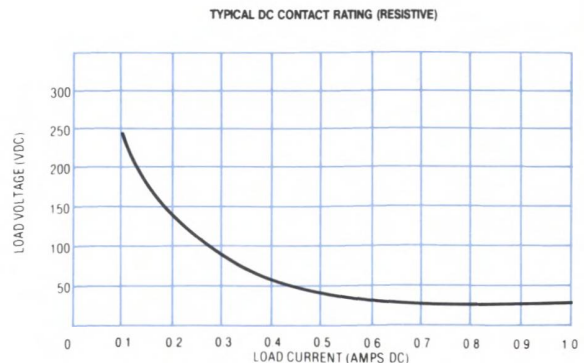
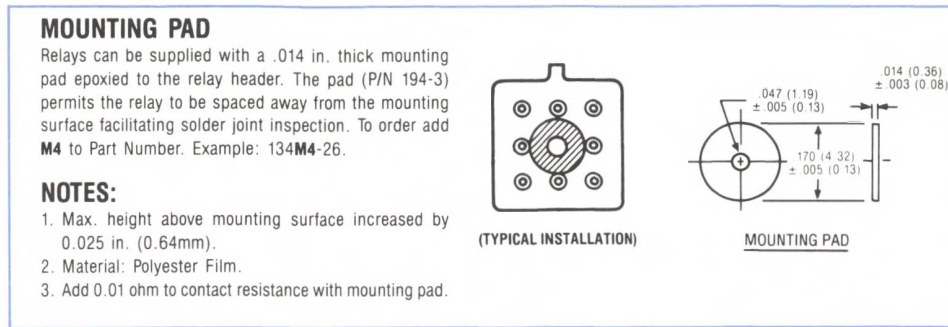
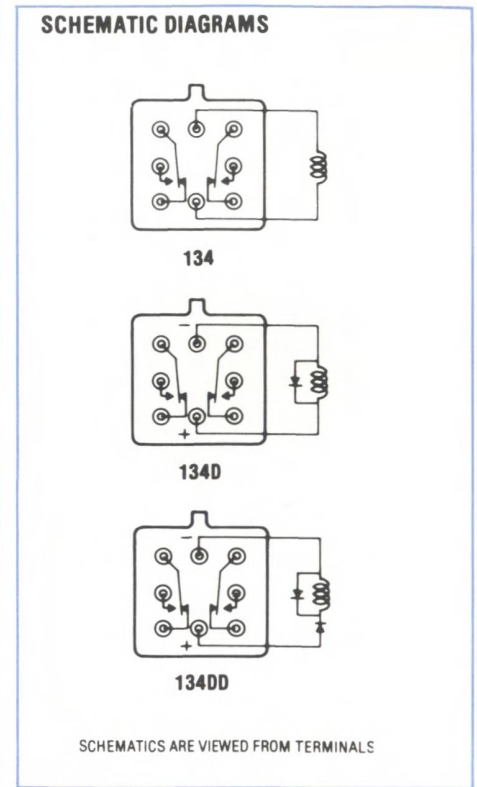
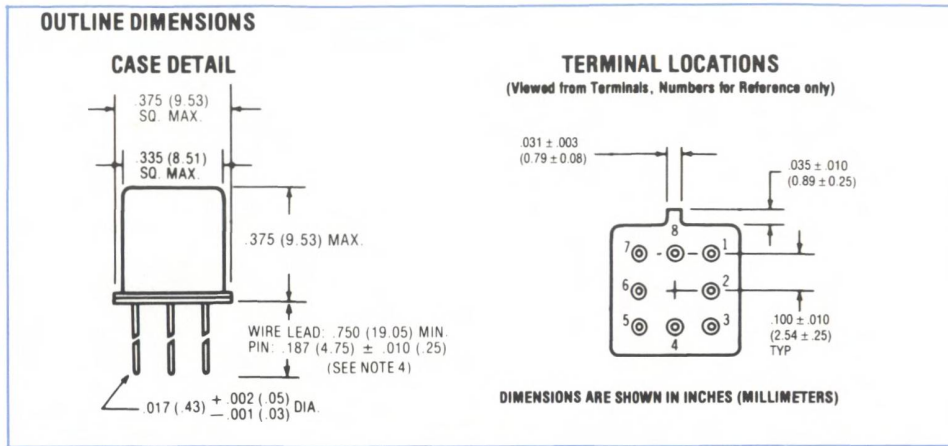

FIGURE 2



MILITARY P/N TO TELEDYNE P/N COMPARISON CHART

REFERENCE M39016/41, /42, /43

SLASH & DASH	TELEDYNE PART NO.*	SLASH & DASH	TELEDYNE PART NO.*	SLASH & DASH	TELEDYNE PART NO.*	SLASH & DASH	TELEDYNE PART NO.*	SLASH & DASH	TELEDYNE PART NO.*	SLASH & DASH	TELEDYNE PART NO.*
/41-033	134-5	/41-053	134M4-36	/42-033	134D-5	/42-053	134DM4-36	/43-033	134DD-5	/43-053	134DDM4-18
-034	-6	-054	-48	-034	-6	-054	-48	-034	-6	-054	-26
-035	-12	-055	-9	-035	-12	-055	-9	-035	-9	-055	-36
-036	-26	-056	-18	-036	-26	-056	-18	-036	-12	-056	-48
-037	-36	/41-057	134Z-5	-037	-36	/42-057	134DZ-5	-037	-18	/43-057	134DDZ-5
-038	-48	-058	-6	-038	-48	-058	-6	-038	-26	-058	-6
-039	-9	-059	-12	-039	-9	-059	-12	-039	-36	-059	-9
-040	-18	-060	-26	-040	-18	-060	-26	-040	-48	-060	-12
/41-041	134S-5	-061	-36	/42-041	134DS-5	-061	-36	/43-041	134DDS-5	-061	-18
-042	-6	-062	-48	-042	-6	-062	-48	-042	-6	-062	-26
-043	-12	-063	-9	-043	-12	-063	-9	-043	-9	-063	-36
-044	-26	-064	-18	-044	-26	-064	-18	-044	-12	-064	-48
-045	-36	/41-065	134ZM4-5	-045	-36	/42-065	134DZM4-5	-045	-18	/43-065	134DDZM4-5
-046	-48	-066	-6	-046	-48	-066	-6	-046	-26	-066	-6
-047	-9	-067	-12	-047	-9	-067	-12	-047	-36	-067	-9
-048	-18	-068	-26	-048	-18	-068	-26	-048	-48	-068	-12
/41-049	134M4-5	-069	-36	/42-049	134DM4-5	-069	-36	/43-049	134DDM4-5	-069	-18
-050	-6	-070	-48	-050	-6	-070	-48	-050	-6	-070	-26
-051	-12	-071	-9	-051	-12	-071	-9	-051	-9	-071	-36
-052	-26	-072	-18	-052	-26	-072	-18	-052	-12	-072	-48

*Add reliability level designator A or B. See Teledyne Relays part numbering system and screening and reliability chart (Note 5).

NOTES:

1. Relays generally conform to the processes, performance and test requirements of MIL-R-28776. Minor variations in procedures, which do not effect performance or reliability, may be incorporated at the manufacturer's discretion.
2. Performance Characteristics are subject to change beyond those allowed by the Military specification when testing is performed beyond the MIL-R-39016 rated life. "Typical" characteristics are based on available data and are best estimates. No on-going verification tests are performed.
3. For reference only. Coil resistance not directly measurable at relay terminals due to internal series semiconductor. 134DD only.
4. Unless otherwise specified, relays are supplied with standard .750" (19.05mm) minimum leads. For optional 0.187" (4.7mm) pin versions, add "S" to part number (i.e., 134-5 becomes 134S-5, 134D-5 becomes 134DS-5, etc.).
5. Screened hi-rel versions available on special order. Contact factory.

RELIABILITY LEVEL	FAILURE RATE %/10,000 CYCLES
A	3.0
B	1.0

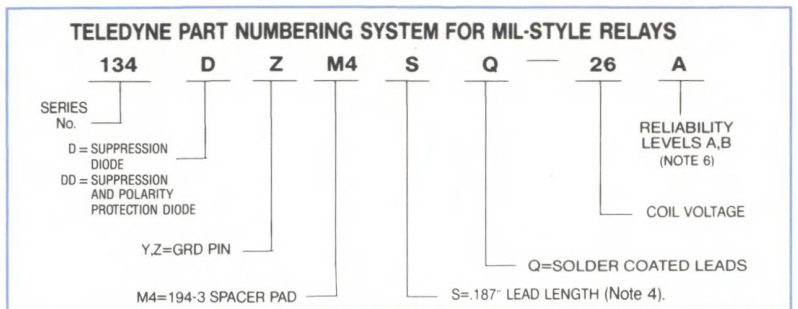

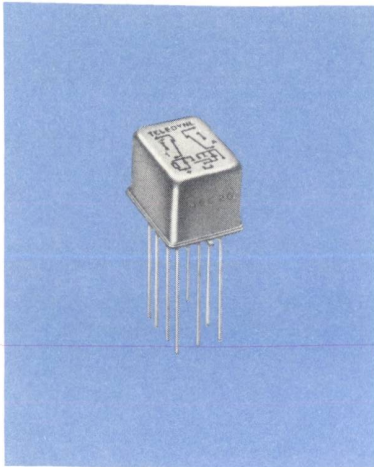

TELEDYNE RELAYS

CENTIGRID[®] MILITARY STYLE RELAY DPDT

SENSITIVE
CMOS COMPATIBLE

SERIES
136C



SERIES DESIGNATION	RELAY TYPE
136C	DPDT sensitive relay with internal power MOS FET driver and diode coil suppression

INTERNAL CONSTRUCTION

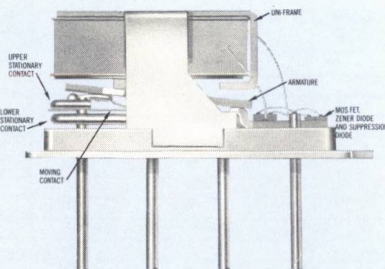

DESCRIPTION

The sensitive 136C Centigrid[®] relay is an ultraminiature, hermetically sealed, armature relay capable of being directly driven by most IC logic families. Its low profile height and .100" grid spaced terminals, which precludes the need for spreader pads, make it ideal for applications where extreme packaging density and/or close PC board spacing are required.

The basic concept and internal structure are similar to the Teledyne DPDT TO-5 relay (412 Series). Unique construction features and manufacturing techniques provide overall high reliability and excellent resistance to environmental extremes:

- All welded construction.
- Unique uni-frame design providing high magnetic efficiency and mechanical rigidity.
- High force/mass ratios for resistance to shock and vibration.
- Advanced cleaning and sealing techniques provide maximum assurance of internal cleanliness.
- Precious metal alloy contact material with gold plating assures excellent high current and dry circuit switching capabilities.

The sensitive 136C Centigrid[®] relay features exceptionally high coil resistance thus providing for extremely low operating power (200 mw typical). The advantages of reduced heat dissipation and power supply demands are obvious.

By virtue of its inherently low intercontact capacitance and contact circuit losses, the Centigrid[®] relay has proven to be an excellent subminiature RF switch for frequency ranges well into the UHF spectrum. A typical RF application for the Centigrid[®] relay is in hand held radio transceivers, wherein the combined features of good RF performance, small size, low coil power dissipation and high reliability make it the preferred relay for Transmit-Receive switching (see Figure 1).

The sensitive 136C Series utilizes an internal silicon diode for coil suppression, a Zener diode to protect the MOSFET gate input, and an N-channel enhancement mode MOSFET chip which enables direct relay interfacing with most Microprocessor and IC logic families (CMOS, TTL and MOS).

ENVIRONMENTAL AND PHYSICAL SPECIFICATIONS	
Temperature (Ambient)	-65°C to +125°C
Vibration	30 g's to 3000 Hz (Note 1)
Shock	75 g's for 6 msec. (Note 1) half-sine
Acceleration	75 g's (Note 1)
Enclosure	All welded, hermetically sealed
Weight	0.18 oz. (5.11 gms) max.

GENERAL ELECTRICAL SPECIFICATIONS (-65°C to +125°C unless otherwise noted) (Notes 1 & 2)

Contact Arrangement	2 Form C (DPDT)	
Rated Duty	Continuous	
Contact Resistance	0.1 ohm max. before life; 0.2 ohm max. after life at 1A/28VDC (measured 1/8" from header)	
Contact Load Ratings (DC) (See Fig. 2 for other DC resistive voltage/current ratings)	Resistive: 1 Amp/28VDC Inductive: 200 mA/28VDC (320 mH) Lamp: 100 mA/28VDC Low Level: 10 to 50 μ A/10 to 50 mV	
Contact Load Ratings (AC)	Resistive: 250 mA/115VAC, 60 and 400Hz (Case ungrounded) 100 mA/115VAC, 60 and 400 Hz (Case grounded)	
Contact Life Ratings	10,000,000 cycles (typical) at low level 1,000,000 cycles (typical) at 0.5A/28VDC resistive 100,000 cycles min. at all other loads specified above	
Contact Overload Rating	2A/28VDC Resistive (100 cycles min.)	
Contact Carry Rating	Contact factory	
Operate Time	4.0 msec. max. at nominal rated coil voltage	
Release Time	7.5 msec. max.	
Contact Bounce	1.5 msec. max.	
Intercontact Capacitance	0.4 pf. typical	
Insulation Resistance	10,000 megohms min. between mutually isolated terminals (Note 3)	
Dielectric Strength	Sea level: 500 VRMS/60 Hz.	70,000 ft.: 125 VRMS/60 Hz. (Note 3)
Diode P.I.V. (VDC)	100 min.	
Negative Coil Transient (VDC)	1.0 max.	
Zener Voltage (VDC)	17 min. to 23 max.	
Zener Leakage Current (μA @ 15.2 VDC)	2.5 max.	
Power FET	Gate Voltage to Turn Off (VDC, Max.)	0.5
Characteristics	Gate Voltage to Turn On (VDC, Min.)	3.8 (Note 5)
-65°C to + 125°C	Drain-Source Voltage (VDC, Max.)	55

DETAILED ELECTRICAL SPECIFICATIONS (-65°C to +125°C unless otherwise specified) (Notes 1 & 2)

CHARACTERISTICS	GENERIC PART NUMBERS	►					
		136C-5	136C-6	136C-9	136C-12	136C-18	136C-26
Coil Voltage (VDC)	Nom.	5.0	6.0	9.0	12.0	18.0	26.5
	Max.	5.6	8.0	12.0	16.0	24.0	32.0
Coil Current (mADC @25°C)	Max.	56.0	33.0	26.4	17.7	13.8	10.2
	Min.	43.0	27.0	17.8	11.3	8.4	5.8
Nominal Coil Operating Power @25°C (Milliwatts)		250	180	203	180	203	219
Pick-up Voltage (VDC) (Note 5)	Max.	4.0	4.9	7.3	9.8	14.6	19.5
Drop-out Voltage (Note 5) (VDC)	Min.	0.13	0.18	0.27	0.36	0.54	0.72
	Max.	2.3	3.2	4.9	6.5	9.8	13.0

PERFORMANCE CURVES (NOTE 2)

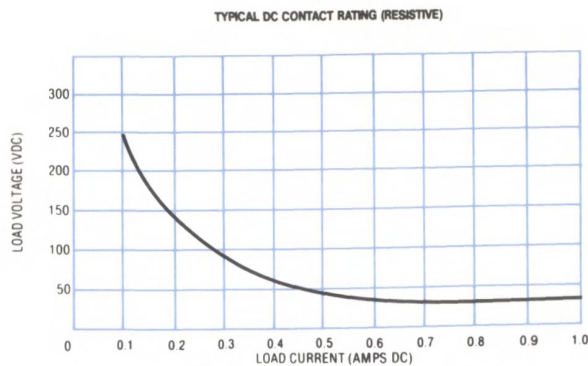
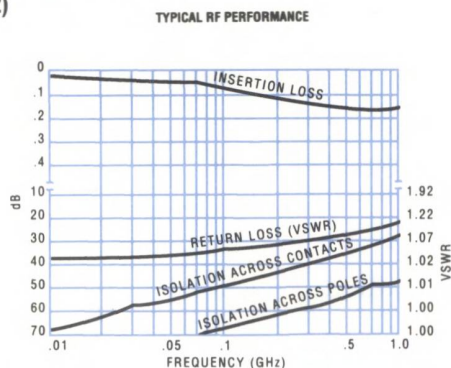

**OUTLINE DIMENSIONS
CASE DETAIL**

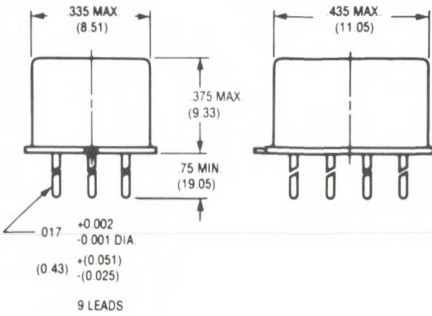

**TERMINAL LOCATIONS
(Viewed from Terminals. Numbers for Reference only)**

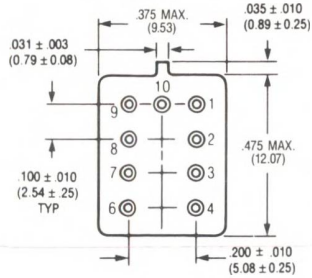

DIMENSIONS ARE SHOWN IN INCHES (MILLIMETERS)

SCHEMATIC DIAGRAM

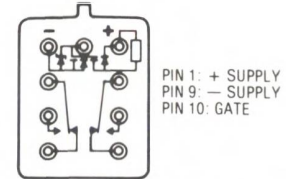

PIN 1: + SUPPLY
PIN 9: - SUPPLY
PIN 10: GATE

SCHEMATIC IS VIEWED FROM TERMINALS

MOUNTING PAD

Relays can be supplied with a .014 in. thick mounting pad epoxied to the relay header. The pad (P/N 194-19) permits the relay to be spaced away from the mounting surface facilitating solder joint inspection. To order add M9 to Part Number. Example: 136CM9-26.

- NOTES:**
1. Max. height above mounting surface increased by 0.025 in. (0.64mm)
 2. Material: Polyester film
 3. Add 0.01 ohm to contact resistance with mounting pad.

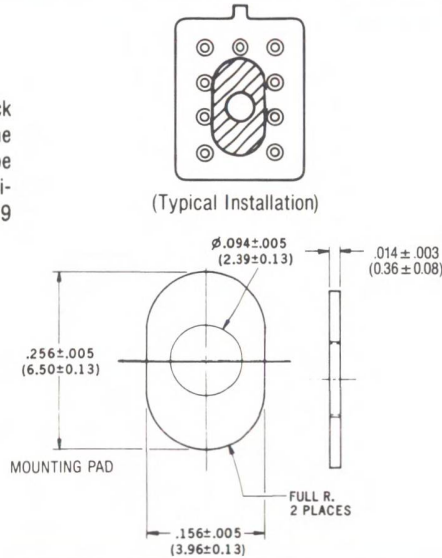

TYPICAL CMOS INTERFACE CIRCUIT

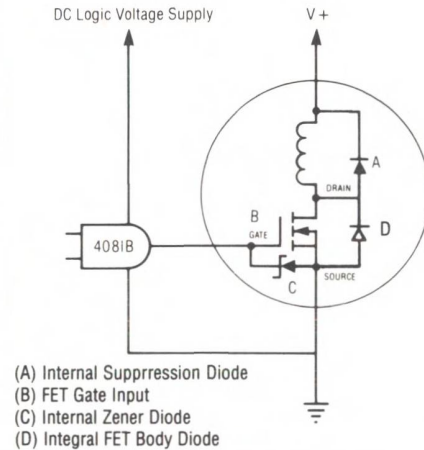

- (A) Internal Suppression Diode
(B) FET Gate Input
(C) Internal Zener Diode
(D) Integral FET Body Diode

MILITARY P/N TO TELEDYNE P/N COMPARISON CHART

REFERENCE M28776/7

SLASH & DASH	TELEDYNE PART NO.*	SLASH & DASH	TELEDYNE PART NO.*
/7-001	136C-5	/7-007	136CM9-5
-002	-6	-008	-6
-003	-9	-009	-9
-004	-12	-010	-12
-005	-18	-011	-18
-006	-26	-012	-26

* Add reliability level designator A or B. See Teledyne Relays part numbering system and screening and reliability chart (Note 4).

NOTES:

1. Relays generally conform to the processes, performance and test requirements of MIL-R-28776. Minor variations in procedures, which do not effect performance or reliability, may be incorporated at the manufacturer's discretion.
2. Performance Characteristics are subject to change beyond those allowed by the Military specification when testing is performed beyond the MIL-R-28776 rated life. "Typical" characteristics are based on available data and are best estimates. No on-going verification tests are performed.
3. Pins 9 and 10 must be shorted when testing for insulation resistance and Dielectric Strength.
4. Screened hi-rel versions available on special order. Contact factory.
5. Maximum rated gate voltage = 15VDC.

RELIABILITY LEVEL	FAILURE RATE %/10,000 CYCLES
A	30
B	10

TELEDYNE PART NUMBERING SYSTEM FOR MIL-STYLE RELAYS

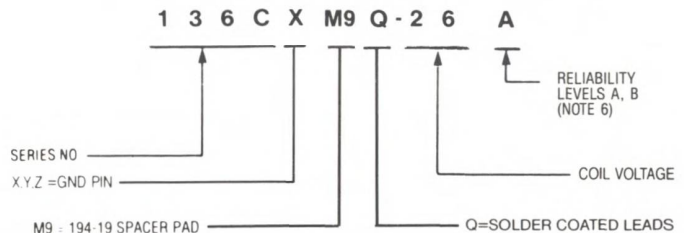

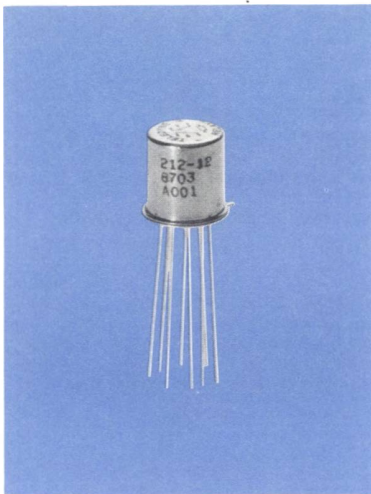

TELEDYNE RELAYS

HIGH CURRENT MILITARY STYLE TO-5 RELAYS

DPDT

SERIES

212

2 AMPERES

INTERNAL CONSTRUCTION

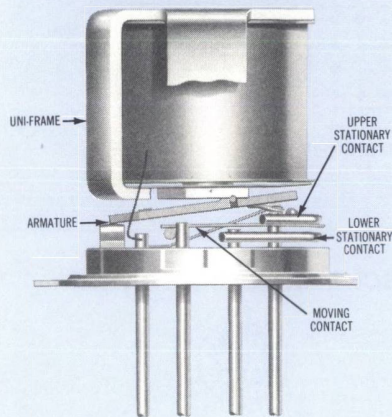

DESCRIPTION

The TO-5 relay, originally conceived and developed by Teledyne, has become the industry standard for reliable switching in electronic systems. Designed expressly for high density PC Board mounting, its small size and low coil power dissipation make the TO-5 relay the most versatile subminiature relay available.

The 212 Series utilizes the Teledyne Relays developed TELESIMUM™ contact system which is resistive load rated at 2 amperes and enables the relay to be used in applications switching lamps, inductors, capacitors, and small motors where current surges at turn-on or turn-off exceed the traditional 1 amp TO-5 relay contact rating.

Unique construction features and manufacturing techniques provide excellent resistance to environmental extremes and overall high reliability:

- All welded construction.
- Unique uni-frame design provides high magnetic efficiency and mechanical rigidity.
- High force/mass ratios for resistance to shock and vibration.
- Advanced cleaning and sealing techniques provide maximum assurance of internal cleanliness.

DETAILED ELECTRICAL SPECIFICATIONS (-65°C to +105°C unless otherwise specified) (NOTE 2)

GENERIC PART NUMBER (NOTE 4)		212-5	212-12	212-26
Coil Voltage (VDC)	Nom.	5.0	12.0	26.5
	Max.	5.5	13.2	29.2
Coil Resistance (Ohms)	±10% @ 25°C	28	200	800
Pick-up Voltage (VDC)	Max.	3.7	9.9	19.8
Must Drop-out Voltage (VDC)		.13	.36	.72
Hold Voltage (VDC)		2.5	6.7	13.4

ENVIRONMENTAL AND PHYSICAL SPECIFICATIONS

Temperature (Ambient)	-65°C to +105°C
Vibration	30 g's to 3000 Hz (Note 3)
Shock	75 g's for 6 msec. (Note 3) half-sine
Acceleration	75 g's (Note 3)
Enclosure	All welded, hermetically sealed
Weight	0.15 oz. (4.3 gms.) max.

SERIES 212

GENERAL ELECTRICAL SPECIFICATIONS (-65°C to +105°C unless otherwise noted) (NOTES 1 AND 2)	
Contact Arrangement	2 Form C (DPDT)
Rated Duty	Continuous
Contact Resistance (Note 6)	0.20 ohm before life; 0.35 ohm after life at 2A/28VDC, (measured 1/8" from header, at 500 mA/28VDC)
Contact Load Ratings (DC) (See Fig. 1 for other DC resistive ratings)	Resistive: 500 mA to 2 Amp/28VDC (Note 5) Inductive: 280 mA @ 320 mH Motor: 800 mA/28VDC Lamp: 200 mA/28VDC
Contact Load Ratings (AC)	Resistive: 500 mA/115VAC, 60 and 400 Hz (Case not grounded) 250 mA/115VAC, 60 and 400 Hz (Case grounded)
Contact Life Ratings	100,000 cycles min. at 2A/28VDC resistive 50,000 cycles min. at all other loads specified above
Contact Overload Rating	3 A/28VDC Resistive (100 cycles min.)
Contact Carry Rating	Contact factory
Coil Operating Power	820 milliwatts typical at nominal rated voltage at 25°C
Operate Time	4.5 msec. max. at nominal rated coil voltage at 25°C
Release Time	2.5 msec. max.
Contact Bounce	2.0 msec. max.
Insulation Resistance	10,000 megohms min. between mutually isolated terminals
Dielectric Strength	Sea level: 500 VRMS/60 Hz 70,000 ft.: 125 VRMS/60 Hz

PERFORMANCE CURVES (NOTE 1)

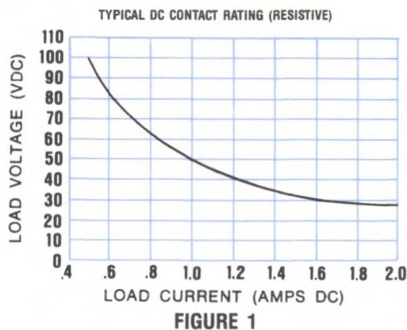

OUTLINE DIMENSIONS

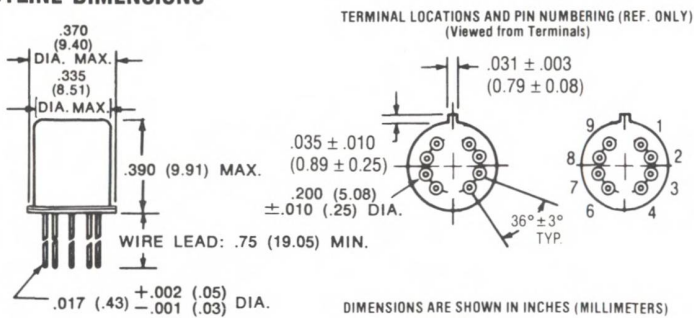

SPREADER PADS

Relays can be supplied with spreader pads installed and cemented in place. P/N 192-10 and 192-59 can be used with all 212 Series Relays. Relays supplied with 192-59 pad installed have leads trimmed to .130 in. (3.3mm) ± .010 (.25mm) below pad. To order, add M for the 192-10 pad, or M2 for the 192-59 pad (e.g., 212M2-26).

NOTES

1. Spreader Pads conform to MIL-M-38527.
2. Material: Diallyl phthalate.
3. Leads exit from holes indicated.
4. Tolerance: .XXX = ±.010 (0.22).
5. With M pad add .025 ohms. With M2 pad add .050 ohms.

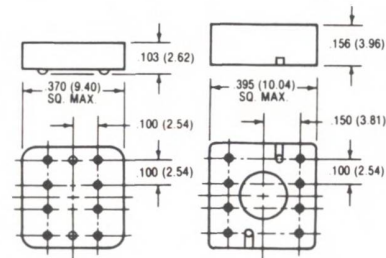

SCHEMATIC DIAGRAM



SCHEMATIC VIEWED FROM TERMINALS

TELEDYNE PART NUMBERING SYSTEM

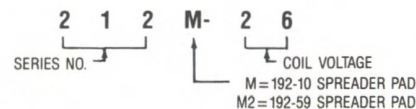

NOTES

1. Characteristics shown as "typical" are based on available data and are best estimates. No on-going verification tests are performed.
2. Characteristics are subject to change after life.
3. Relays will exhibit no contact chatter in excess of 10 μsec or transfer in excess of 1 μsec.
4. Screened hi-rel versions available on special order.
5. Not suitable for use below 500 mA resistive.
6. Values indicated are average maximums. Actual measured values may be slightly higher.

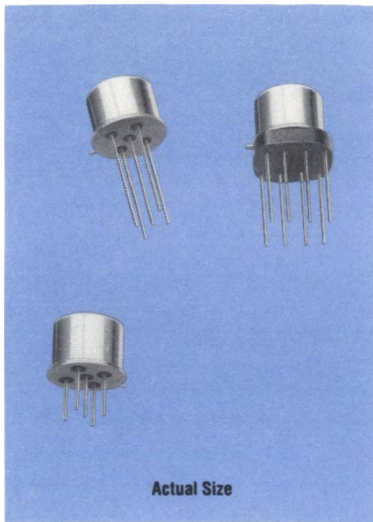

TELEDYNE RELAYS

MILITARY STYLE TO-5 RELAYS

SPDT

SERIES
411



SERIES DESIGNATION	RELAY TYPE
411	SPDT basic relay
411D	SPDT relay with internal diode for coil transient suppression
411DD	SPDT relay with internal diodes for coil transient suppression and polarity reversal protection
411T	SPDT relay with internal transistor driver and coil transient suppression diode

INTERNAL CONSTRUCTION

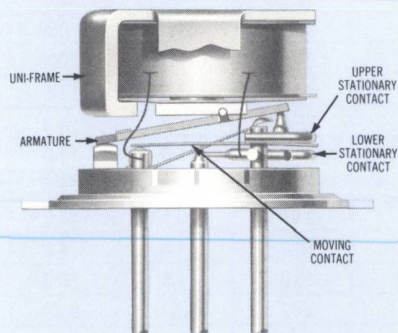

DESCRIPTION

The TO-5 relay, originally conceived and developed by Teledyne, has become the industry standard for low level switching from dry circuit to 1 ampere. Designed expressly for high density PC Board mounting, its small size and low coil power dissipation make the TO-5 relay the most versatile subminiature relay available.

Unique construction features and manufacturing techniques provide excellent resistance to environmental extremes and overall high reliability.

- All welded construction.
- Unique uni-frame design providing high magnetic efficiency and mechanical rigidity.
- High force/mass ratios for resistance to shock and vibration.
- Advanced cleaning and sealing techniques provide maximum assurance of internal cleanliness.
- Precious metal alloy contact material with gold plating assures excellent high current and dry circuit switching capabilities.

The 411D and 411DD Series utilize internal discrete silicon diodes, with characteristics similar to 1N5315. The hybrid 411T Series features a silicon diode and transistor chip (similar to 2N2222A). The integrated packaging of the relay with its associated semi-conductor devices greatly reduces PC Board floor space requirements as well as component installation costs.

By virtue of its inherently low intercontact capacitance and contact circuit losses, the TO-5 relay has proven to be an excellent subminiature RF switch for frequency ranges well into the UHF spectrum. A typical RF application for the TO-5 relay is in hand held radio transceivers, wherein the combined features of good RF performance, small size, low coil power dissipation and high reliability make it the preferred relay for T-R switching (see Figure 1).

ENVIRONMENTAL AND PHYSICAL SPECIFICATIONS

Temperature (Ambient)	-65°C to +125°C
Vibration	30 g's to 3000 Hz (Note 1)
Shock	75 g's for 6 msec. (Note 1) half-sine
Acceleration	75 g's (Note 1)
Enclosure	All welded, hermetically sealed
Weight	0.089 oz. (2.52 gms.) max.

SERIES 411

GENERAL ELECTRICAL SPECIFICATIONS (-65° to +125°C unless otherwise noted) (Notes 1 & 2)

Contact Arrangement	1 Form C (SPDT)	
Rated Duty	Continuous	
Contact Resistance	0.1 ohm max. before life; 0.2 ohm max. after life at 1A/28VDC (measured 1/8" from header)	
Contact Load Ratings (DC) (See Fig. 2 for other DC resistive voltage/current ratings)	Resistive: 1 Amp/28VDC Inductive: 200 mA/28VDC (320 mH) Lamp: 100 mA/28VDC Low Level: 10 to 50 μ A/10 to 50 mV	
Contact Load Ratings (AC)	Resistive: 250 mA/115VAC, 60 and 400Hz (Case not grounded) 100 mA/115VAC, 60 and 400 Hz (Case grounded)	
Contact Life Ratings	10,000,000 cycles (typical) at low level 1,000,000 cycles (typical) at 0.5A/28VDC resistive 100,000 cycles min. at all other loads specified above	
Contact Overload Rating	2 A/28VDC Resistive (100 cycles min.)	
Contact Carry Rating	Contact factory	
Coil Operating Power	300 milliwatts typical at nominal rated voltage at 25°C	
Operate Time	2.0 msec. max. at nominal rated coil voltage	
Release Time	411 Series: 1.5 msec max.	411D, 411DD, 411T Series: 4.0 msec. max.
Contact Bounce	1.5 msec. max.	
Intercontact Capacitance	0.4 pf. typical	
Insulation Resistance	10,000 megohms min. between mutually isolated terminals	
Dielectric Strength	Sea level: 500 VRMS/60 Hz.	70,000 ft.: 300 VRMS/60 Hz (411T: 125 VRMS/60 Hz)
Negative Coil Transient (VDC)	411D, 411DD, 411T	1.0 max.
Diode P.I.V. (VDC)	411D, 411DD, 411T	100 min.
411T Transistor Characteristics	Base Turn Off Voltage (VDC)	0.3 min.
	Emitter-base breakdown Voltage (BV_{EBO}) (@ 25°C) (VDC)	6.0 min.
	Collector-base breakdown Voltage (BV_{CBO}) (@ 25°C & I_c = 100 μA) (VDC)	80 min.

DETAILED ELECTRICAL SPECIFICATIONS (-65°C to +125°C unless otherwise noted) (Notes 1 & 2)

	GENERIC PART NUMBERS	411-5	411-6	411-9	411-12	411-18	411-26
		411D-5 411DD-5 411T-5	411D-6 411DD-6 411T-6	411D-9 411DD-9 411T-9	411D-12 411DD-12 411T-12	411D-18 411DD-18 411T-18	411D-26 411DD-26 411T-26
Coil Voltage (VDC)	Nom.	5.0	6.0	9.0	12.0	18.0	26.5
	Max.	6.0	8.0	12.0	16.0	24.0	32.0
Coil Resistance (Ohms \pm 10% @ 25°C)	411, 411D, 411T (Note 3)	63	125	280	500	1130	2000
	411DD (Note 3)	50	98	280	500	1130	2000
Coil Current (mA DC @ 25°C) (411DD Series)	Min.	72.7	46.3	25.9	20.0	13.6	11.5
	Max.	100	62.4	33.7	25.6	17.2	14.4
Coil Current (mA DC @ 25°C) (411T Series)	(Note 7) Min.	66.6	42.0	28.0	20.9	13.8	11.5
	Max.	89.6	55.5	38.1	28.1	18.8	15.5
Pick-up Voltage (VDC, Max.)	411, 411D	3.7	4.5	6.8	9.0	13.5	18.0
	411DD	4.5	5.5	7.8	10.0	14.5	19.0
	411T (Note 7)	3.9	5.2	7.8	10.0	14.5	19.0
Base Current to Turn On (mA DC, Max.) (411T Series) (Note 7)		2.38	1.60	1.07	0.80	0.53	0.40
Drop-out Voltage (VDC) (See Note 7 for 411T Series)	Min.	0.15	0.18	0.35	0.40	0.58	0.89
	Max.	2.4	2.8	4.2	5.6	8.4	10.4

PERFORMANCE CURVES (NOTE 2)

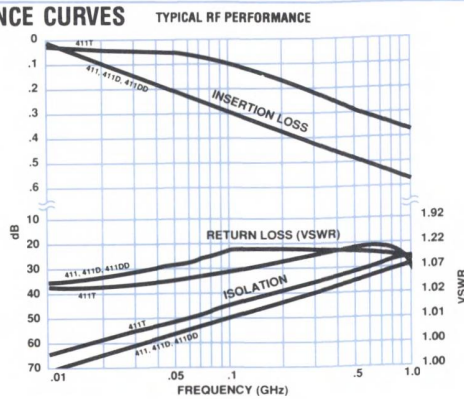

FIGURE 1

TYPICAL DC CONTACT RATING (RESISTIVE)

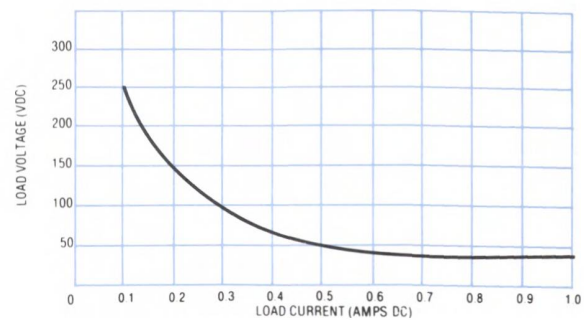
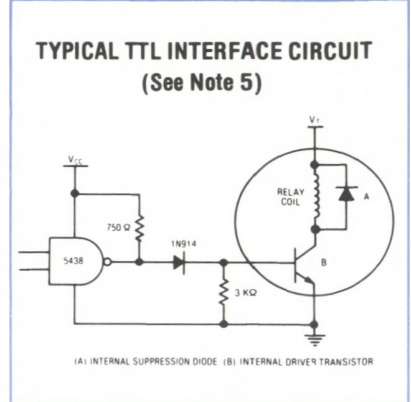
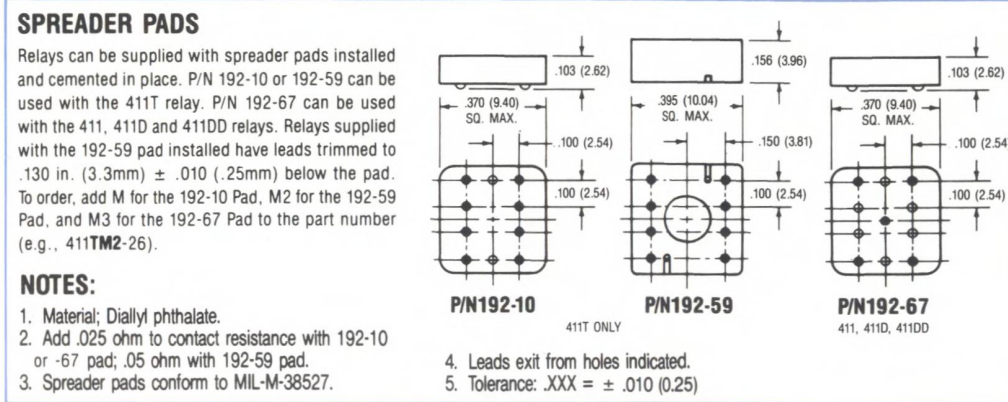
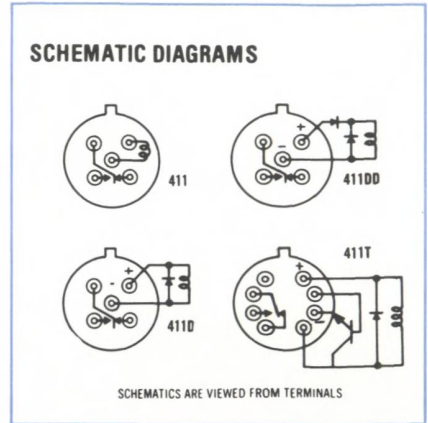
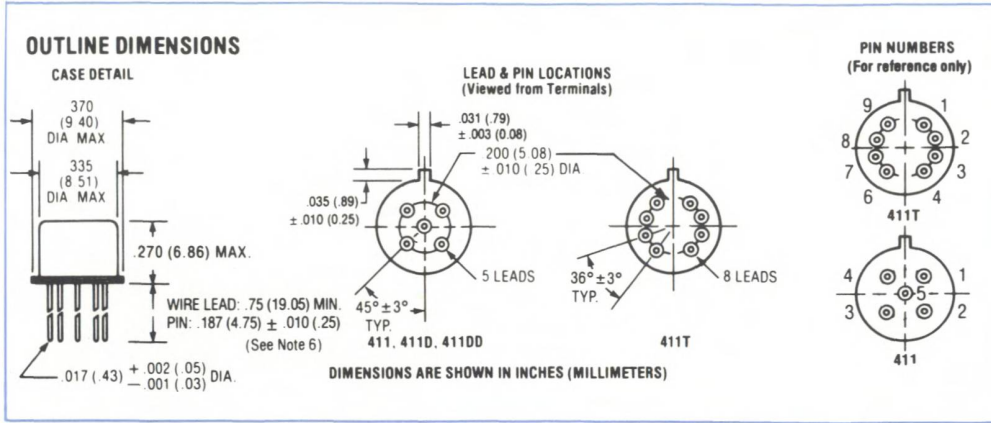

FIGURE 2



MILITARY P/N TO TELEDYNE P/N COMPARISON CHART

REFERENCE M39016/7, /23, /24 REFERENCE M28776/5

SLASH & DASH	TELEDYNE PART NO.*	SLASH & DASH	TELEDYNE PART NO.*	SLASH & DASH	TELEDYNE PART NO.*	SLASH & DASH	TELEDYNE PART NO.*
/7-013	**	/23-013	**	/24-013	**	/5-013	**
-015	**	-014	**	-014	**	-014	**
-017	**	-015	**	-015	**	-015	**
-019	**	-016	**	-016	**	-016	**
-021	**	-017	**	-017	**	-017	**
-023	**	-018	**	-018	**	-018	**
/7-014	411S-5	/23-019	411DS-5	/24-019	411DDS-5	/5-019	411TS-5
-016	-6	-020	-6	-020	-6	-020	-6
-018	-9	-021	-9	-021	-9	-021	-9
-020	-12	-022	-12	-022	-12	-022	-12
-022	-18	-023	-18	-023	-18	-023	-18
-024	-26	-024	-26	-024	-26	-024	-26
/7-025	411-5	/23-025	411D-5	/24-025	411DD-5	/5-025	411T-5
-026	-6	-026	-6	-026	-6	-026	-6
-027	-9	-027	-9	-027	-9	-027	-9
-028	-12	-028	-12	-028	-12	-028	-12
-029	-18	-029	-18	-029	-18	-029	-18
-030	-26	-030	-26	-030	-26	-030	-26
/7-031	411M-5	/23-031	411DM-5	/24-031	411DDM-5	/5-031	411TM-5
-032	-6	-032	-6	-032	-6	-032	-6
-033	-9	-033	-9	-033	-9	-033	-9
-034	-12	-034	-12	-034	-12	-034	-12
-035	-18	-035	-18	-035	-18	-035	-18
-036	-26	-036	-26	-036	-26	-036	-26

NOTES:

1. Relays generally conform to the processes, performance and test requirements of MIL-R-39016 or MIL-R-28776, as applicable. Minor variations in procedures, which do not effect performance or reliability, may be incorporated at the manufacturer's discretion.
2. Performance Characteristics are subject to change beyond those allowed by the applicable Military specification when testing is performed beyond the MIL-R-39016 or MIL-R-28776 rated life. "Typical" characteristics are based on available data and are best estimates. No on-going verification tests are performed.
3. For reference only. Coil resistance not directly measurable at relay terminals due to internal series semiconductor. 411DD and 411T only.
4. Screened hi-rel versions available on special order. Contact factory.
5. Circuit is typical for all 411T Series. Values shown are for 411T-5 relay, and apply over full operating temperature range.
6. Unless otherwise specified, relays are supplied with standard 0.75" (19.05mm) minimum leads. For optional 0.187" (4.75mm) pin versions, add "S" to part number (i.e., 411-5 becomes 411S-5).
7. Limit base-emitter current to 15 mA DC.

RELIABILITY LEVEL	FAILURE RATE %/10,000 CYCLES
A	3.0
B	1.0

*Add reliability level designator A or B. See Teledyne Relays part numbering system and screening and reliability chart (Note 4).
 **Not recommended for new design. See Note 6.

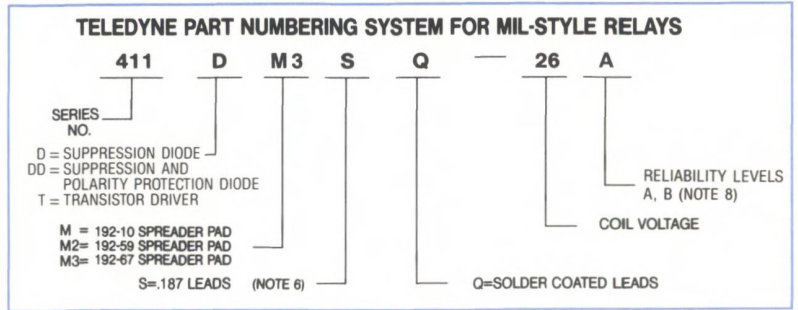

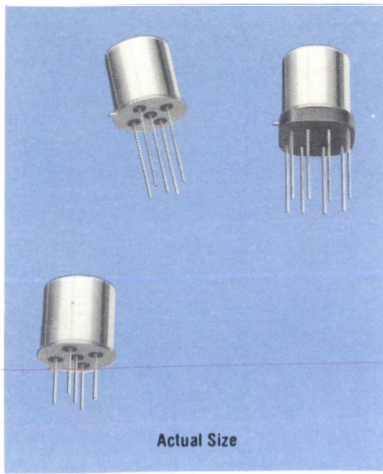

TELEDYNE RELAYS

MILITARY STYLE TO-5 RELAYS

SENSITIVE SPDT

SERIES
431
TRTM

SERIES DESIGNATION	RELAY TYPE
431	SPDT basic relay
431D	SPDT relay with internal diode for coil transient suppression
431DD	SPDT relay with internal diodes for coil transient suppression and polarity reversal protection
431T	SPDT relay with internal transistor driver and coil transient suppression diode

INTERNAL CONSTRUCTION

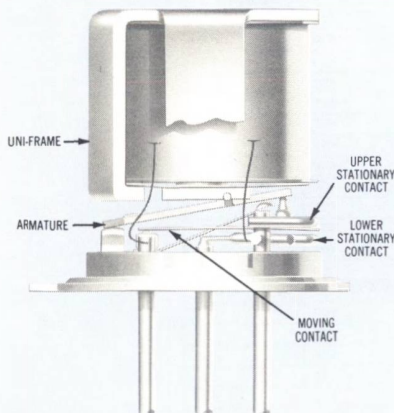

DESCRIPTION

The TO-5 relay, originally conceived and developed by Teledyne, has become the industry standard for low level switching from dry circuit to 1 ampere. Designed expressly for high density PC Board mounting, its small size and low coil power dissipation make the TO-5 relay the most versatile subminiature relay available.

Unique construction features and manufacturing techniques provide excellent resistance to environmental extremes and overall high reliability.

- All welded construction.
- Unique uni-frame design providing high magnetic efficiency and mechanical rigidity.
- High force/mass ratios for resistance to shock and vibration.
- Advanced cleaning and sealing techniques provide maximum assurance of internal cleanliness.
- Precious metal alloy contact material with gold plating assures excellent high current and dry circuit switching capabilities.

The 431D and 431DD Series utilize internal discrete silicon diodes, with characteristics similar to 1N5315. The hybrid 431T Series features a silicon diode and transistor chip (similar to 2N2222A). The integrated packaging of the relay with its associated semi-conductor devices greatly reduces PC Board floor space requirements as well as component installation costs.

By virtue of its inherently low intercontact capacitance and contact circuit losses, the TO-5 relay has proven to be an excellent subminiature RF switch for frequency ranges well into the UHF spectrum. A typical RF application for the TO-5 relay is in hand held radio transceivers, wherein the combined features of good RF performance, small size, low coil power dissipation and high reliability make it the preferred relay for T-R switching (see Figure 1).

ENVIRONMENTAL AND PHYSICAL SPECIFICATIONS

Temperature (Ambient)	-65°C to +125°C
Vibration	30 g's to 3000 Hz (Note 1)
Shock	75 g's for 6 msec. (Note 1) half-sine
Acceleration	75 g's (Note 1)
Enclosure	All welded, hermetically sealed
Weight	0.109 oz. (3.09 gms.) max.

GENERAL ELECTRICAL SPECIFICATIONS (-65°C to +125°C unless otherwise noted) (Notes 1 & 2)

Contact Arrangement	1 Form C (SPDT)	
Rated Duty	Continuous	
Contact Resistance	0.1 ohm max. before life; 0.2 ohm max. after life at 1A/28VDC (measured 1/8" from header)	
Contact Load Ratings (DC) (See Fig. 2 for other DC resistive voltage/current ratings)	Resistive: 1 Amp/28VDC Inductive: 200 mA/28VDC (320 mH) Lamp: 100 mA/28VDC Low Level: 10 to 50 μ A/10 to 50 mV	
Contact Load Ratings (AC)	Resistive: 250 mA/115VAC, 60 and 400 Hz (Case not grounded) 100 mA/115VAC, 60 and 400 Hz (Case grounded)	
Contact Life Ratings	10,000,000 cycles (typical) at low level 1,000,000 cycles (typical) at 0.5A/28VDC resistive 100,000 cycles min. at all other loads specified above	
Contact Overload Rating	2A/28VDC Resistive (100 cycles min.)	
Contact Carry Rating	Contact factory	
Coil Operating Power	150 milliwatts typical at nominal rated voltage at 25°C	
Operate Time	431, 431D, 431DD Series: 4.0 msec. max. at nominal rated coil voltage	431T: 3.5 msec. (Note 7)
Release Time	431 Series: 2.5 msec. max.	431D, 431DD 431T Series: 7.5 msec. max.
Contact Bounce	1.5 msec. max.	
Intercontact Capacitance	0.4 pf. typical	
Insulation Resistance	10,000 megohms min. between mutually isolated terminals	
Dielectric Strength	Sea Level: 500 VRMS/60 Hz	70,000 ft.: 300 VRMS/60 Hz (431T: 125 VRMS/60 Hz)
Negative Coil Transient (VDC) (431D, 431DD, 431T)	1.0 max.	
Diode P.I.V.(VDC) (431D, 431DD, 431T)	100 min.	
431T Transistor Characteristics	Base Turn-Off Voltage (VDC)	0.3 min.
	Emitter-base breakdown Voltage (BV_{EB0}) (@25°C) (VDC)	6.0 min.
	Collector-base breakdown Voltage (BV_{CB0}) (@25°C & I_c = 100μA) (VDC)	80 min.

DETAILED ELECTRICAL SPECIFICATIONS (-65°C to +125°C unless otherwise noted) (Notes 1 & 2)

	GENERIC PART NUMBERS	➔	431-5	431-6	431-9	431-12	431-18	431-26	431-32	431-40
			431D-5 431DD-5 431T-5	431D-6 431DD-6 431T-6	431D-9 431DD-9 431T-9	431D-12 431DD-12 431T-12	431D-18 431DD-18 431T-18	431D-26 431DD-26 431T-26	431D-32 431DD-32 431T-32	431D-40 431DD-40 431T-40
Coil Voltage (VDC)	Nom.		5.0	6.0	9.0	12.0	18.0	26.5	32.0	40.0
	Max.		8.0	11.0	16.0	22.0	33.0	45.0	57.0	75.0
Coil Resistance (Ohms \pm 10% AT 25°C)	431, 431D, 431T (Note 3)		125	255	630	1025	2300	4000	6500	11,000
	431DD (Note 3)		100	200	630	1025	2300	4000	6500	11,000
Coil Current (mA DC AT 25°C) (431DD Series)		Min.	36.3	22.7	11.5	9.7	6.7	5.7	4.3	3.2
		Max.	50.0	30.6	15.0	12.5	8.5	7.2	5.4	4.0
Coil Current (mA DC AT 25°C) (431T Series)	(Note 7)	Min.	34.7	21.2	11.8	10.1	6.7	5.7	4.2	3.1
		Max.	47.8	27.7	16.8	13.6	9.1	7.7	5.8	4.3
Pick-up Voltage (VDC, Max.)	431, 431D		3.7	4.5	6.8	9.0	13.5	18.0	24.0	30.0
	431DD		4.5	5.5	7.8	10.0	14.5	19.0	26.0	27.0
	431T (Note 7)		3.6	4.8	7.8	10.0	14.5	19.0	24.0	30.0
Base Current to Turn On (mA DC, Max.) (431T Series)			1.2	0.78	0.48	0.39	0.26	0.20	0.16	0.13
Drop-out Voltage	431, 431D, 431T (Note 7)	Min.	0.15	0.18	0.35	0.41	0.58	0.89	1.0	1.3
		Max.	2.0	2.8	4.2	5.6	8.4	10.4	15.0	18.7
	431DD	Min.	0.15	0.18	0.35	0.40	0.58	0.89	0.95	1.28
		Max.	2.4	2.8	4.2	5.6	8.4	10.4	12.6	15.7

PERFORMANCE CURVES (NOTE 2)

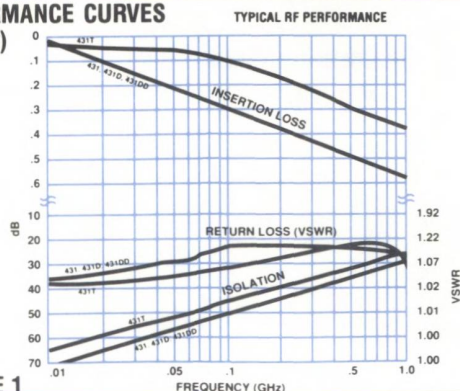

FIGURE 1

TYPICAL DC CONTACT RATING (RESISTIVE)

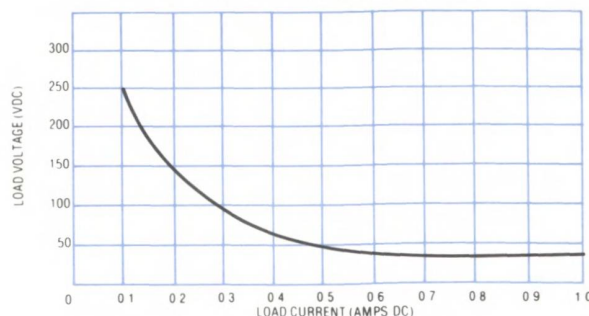
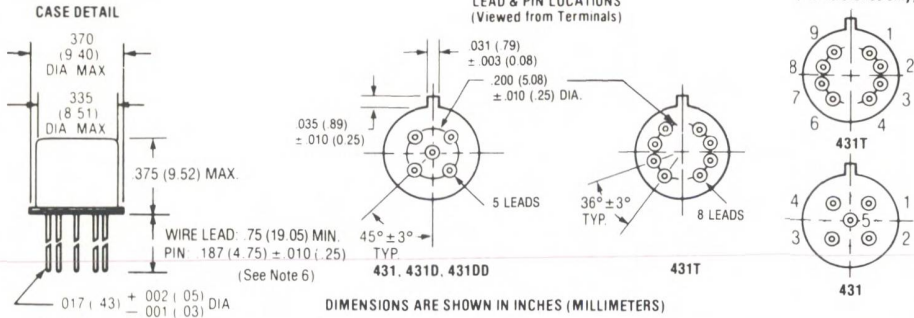
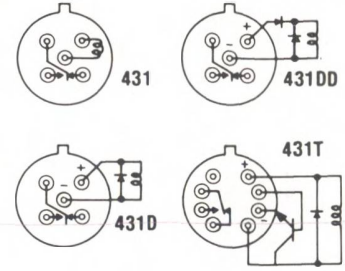

FIGURE 2

OUTLINE DIMENSIONS



SCHEMATIC DIAGRAMS



SCHEMATICS ARE VIEWED FROM TERMINALS

SPREADER PADS

Relays can be supplied with spreader pads installed and cemented in place. P/N 192-10 or 192-59 can be used with the 431T relay. P/N 192-67 can be used with the 431, 431D and 431DD relays. Relays supplied with the 192-59 pad installed have leads trimmed to .130 in. (3.3mm) ± .010 (.25mm) below the pad. To order, add M for the 192-10 Pad, M2 for the 192-59 Pad, and M3 for the 192-67 Pad to the part number (e.g., 431TM2-26).

NOTES:

1. Material: Diallyl phthalate.
2. Add .025 ohm to contact resistance with 192-10 or -67 pad; .05 ohm with 192-59 pad.
3. Spreader pads conform to MIL-M-38527.
4. Leads exit from holes indicated.
5. Tolerance: .XXX = ±.010 (0.25)

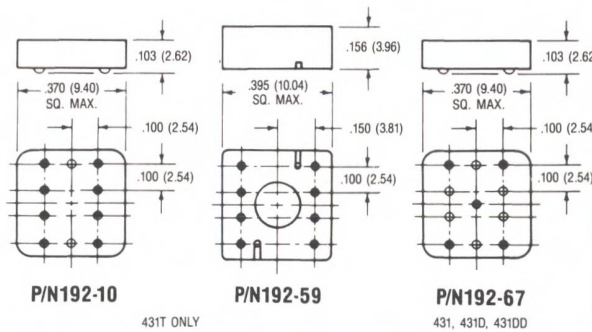

TYPICAL TTL INTERFACE CIRCUIT (See Note 5)

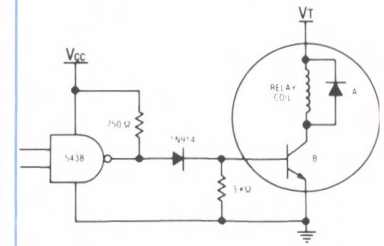

(A) INTERNAL SUPPRESSION DIODE
(B) INTERNAL DRIVER TRANSISTOR

MILITARY P/N TO TELEDYNE P/N COMPARISON CHART
REFERENCE M39016/10, /25, /26

SLASH & DASH	TELEDYNE PART NO.*	SLASH & DASH	TELEDYNE PART NO.*	SLASH & DASH	TELEDYNE PART NO.*	SLASH & DASH	TELEDYNE PART NO.*	SLASH & DASH	TELEDYNE PART NO.*	SLASH & DASH	TELEDYNE PART NO.*
/10-017	**	/10-041	431M-5	/25-033	431D-5	/26-025	431DD-5	/4-017	**	/4-041	431TM-5
-019	**	-042	-6	-034	-6	-026	-6	-018	**	-042	-6
-021	**	-043	-12	-035	-12	-027	-12	-019	**	-043	-9
-023	**	-044	-26	-036	-26	-028	-26	-020	**	-044	-12
-025	**	-045	-32	-037	-32	-029	-32	-021	**	-045	-18
-027	**	-046	-40	-038	-40	-030	-40	-022	**	-046	-26
-029	**	-047	-9	-039	-9	-031	-9	-023	**	-047	-32
-031	**	-048	-18	-040	-18	-032	-18	-024	**	-048	-40
/10-018	431S-5	/25-017	**	/25-041	431DM-5	/26-033	431DD-5	/4-025	431TS-5		
-020	-6	-018	**	-042	-6	-034	-6	-026	-6		
-022	-12	-019	**	-043	-12	-035	-12	-027	-9		
-024	-26	-020	**	-044	-26	-036	-26	-028	-12		
-026	-32	-021	**	-045	-32	-037	-32	-029	-18		
-028	-40	-022	**	-046	-40	-038	-40	-030	-26		
-030	-9	-023	**	-047	-9	-039	-9	-031	-32		
-032	-18	-024	**	-048	-18	-040	-18	-032	-40		
/10-033	431-5	/25-025	431DS-5	/26-017	**	/26-041	431DDM-5	/4-033	431T-5		
-034	-6	-026	-6	-018	**	-042	-6	-034	-6		
-035	-12	-027	-12	-019	**	-043	-12	-035	-9		
-036	-26	-028	-26	-020	**	-044	-26	-036	-12		
-037	-32	-029	-32	-021	**	-045	-32	-037	-18		
-038	-40	-030	-40	-022	**	-046	-40	-038	-26		
-039	-9	-031	-9	-023	**	-047	-9	-039	-32		
-040	-18	-032	-18	-024	**	-048	-18	-040	-40		

REFERENCE M28776/4

*Add reliability level designator A or B. See Teledyne Relays part numbering system and screening and reliability chart (Note 4).

**Not recommended for new design. See Note 6.

NOTES:

1. Relays generally conform to the processes, performance and test requirements of MIL-R-39016 or MIL-R-28776, as applicable. Minor variations in procedures, which do not effect performance or reliability, may be incorporated at the manufacturer's discretion.
2. Performance Characteristics are subject to change beyond those allowed by the applicable Military specification when testing is performed beyond the MIL-R-39016 or MIL-R-28776 rated life. "Typical" characteristics are based on available data and are best estimates. No on-going verification tests are performed.
3. For reference only. Coil resistance not directly measurable at relay terminals due to internal series semiconductor. 431DD and 431T only.
4. Screened hi-rel versions available on special order. Contact factory.
5. Circuit is typical for all 431T Series. Values shown are for 431T-5 relay, and apply over full operating temperature range.
6. Unless otherwise specified, relays are supplied with standard 0.75" (19.05mm) minimum leads. For optional 0.187" (4.75mm) pin versions, add "S" to part number (i.e., 431-5 becomes 431S-5, 431D-5 becomes 431DS-5, etc.).
7. Limit base-emitter current to 15 mA DC.

RELIABILITY LEVEL	FAILURE RATE %/10,000 CYCLES
A	3.0
B	1.0

TELEDYNE PART NUMBERING SYSTEM FOR MIL-STYLE RELAYS

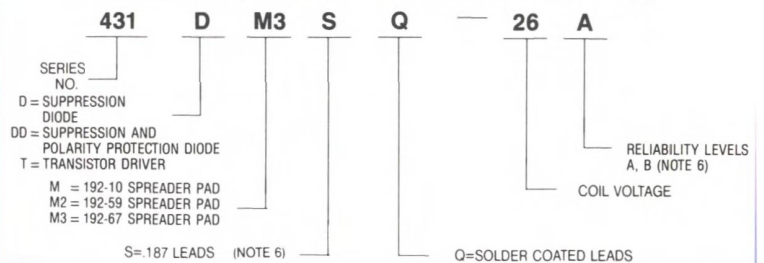

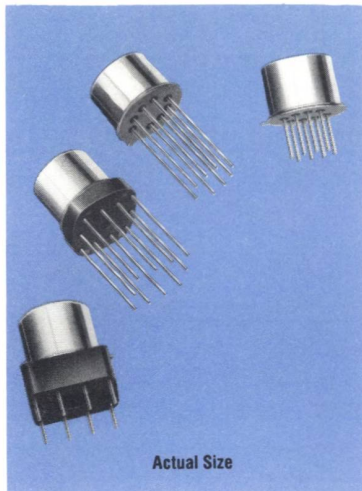

TELEDYNE RELAYS

MILITARY STYLE TO-5 RELAYS

DPDT

SERIES
412

TRTM

SERIES DESIGNATION	RELAY TYPE
412	DPDT basic relay
412D	DPDT relay with internal diode for coil transient suppression
412DD	DPDT relay with internal diodes for coil transient suppression and polarity reversal protection
412T	DPDT relay with internal transistor driver and coil transient suppression diode

INTERNAL CONSTRUCTION

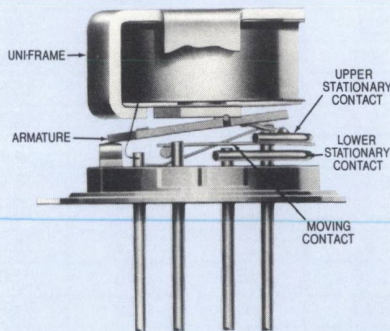

DESCRIPTION

The TO-5 relay, originally conceived and developed by Teledyne, has become the industry standard for low level-switching from dry circuit to 1 ampere. Designed expressly for high density PC Board mounting, its small size and low coil power dissipation make the TO-5 relay the most versatile subminiature relay available.

Unique construction features and manufacturing techniques provide excellent resistance to environmental extremes and overall high reliability.

- All welded construction.
- Unique uni-frame design providing high magnetic efficiency and mechanical rigidity.
- High force/mass ratios for resistance to shock and vibration.
- Advanced cleaning and sealing techniques provide maximum assurance of internal cleanliness.
- Precious metal alloy contact material with gold plating assures excellent high current and dry circuit switching capabilities.

The 412D and 412DD Series utilize internal discrete silicon diodes, with characteristics similar to 1N5315. The hybrid 412T Series features a silicon diode and transistor chip (similar to 2N2222A). The integrated packaging of the relay with its associated semi-conductor devices greatly reduces PC Board floor space requirements as well as component installation costs.

By virtue of its inherently low intercontact capacitance and contact circuit losses, the TO-5 relay has proven to be an excellent subminiature RF switch for frequency ranges well into the UHF spectrum. A typical RF application for the TO-5 relay is in hand held radio transceivers, wherein the combined features of good RF performance, small size, low coil power dissipation and high reliability make it the preferred relay for T-R switching (see Figure 1).

ENVIRONMENTAL AND PHYSICAL SPECIFICATIONS

Temperature (Ambient)	-65°C to +125°C
Vibration	30 g's to 3000 Hz (Note 1)
Shock	75 g's for 6 msec. (Note 1) half-sine
Acceleration	75 g's (Note 1)
Enclosure	All welded, hermetically sealed
Weight	0.09 oz. (2.55 gms.) max.

SERIES 412

GENERAL ELECTRICAL SPECIFICATIONS (-65°C to + 125°C unless otherwise noted) (Notes 1 & 2)

Contact Resistance	0.1 ohm max. before life; 0.2 ohm max. after life at 1A/28VDC (measured 1/8" from header)		
Contact Load Ratings (DC) (See Fig. 2 for other DC resistive voltage/current ratings)	Resistive: 1 Amp/28VDC Inductive: 200 mA/28VDC (320 mH) Lamp: 100 mA/28VDC Low Level: 10 to 50 μ A/10 to 50 mV		
Contact Load Ratings (AC)	Resistive: 250 mA/115VAC, 60 and 400Hz (Case not grounded) 100 mA/115VAC, 60 and 400 Hz (Case grounded)		
Contact Life Ratings	10,000,000 cycles (typical) at low level 1,000,000 cycles (typical) at 0.5A/28VDC resistive 100,000 cycles min. at all other loads specified above		
Contact Overload Rating	2A/28VDC Resistive (100 cycles min.)		
Contact Carry Rating	Contact factory		
Coil Operating Power	450 milliwatts typical at nominal rated voltage at 25°C		
Operate Time	2.0 msec. max. at nominal rated coil voltage		
Release Time	412 Series: 1.5 msec. max.	412D, 412DD Series: 4.0 msec. max.	412T: 7.5 msec. max.
Contact Bounce	1.5 msec. max.		
Intercontact Capacitance	0.4 pf. typical		
Insulation Resistance	10,000 megohms min. between mutually isolated terminals		
Dielectric Strength	Sea level: 500 VRMS/60 Hz.	70,000 ft.: 125 VRMS/60 Hz.	
Negative Coil Transient (VDC)	412D, 412DD, 412T	1.0 max.	
Diode P.I.V. (VDC)	412D, 412DD, 412T	100 min.	
412T Transistor Characteristics	Base Turn Off Voltage (VDC)	0.3 min.	
	Emitter-base breakdown Voltage (BV_{EB0}) (@25°C) (VDC)	6.0 min.	
	Collector-base breakdown Voltage (BV_{CB0}) (@25°C & I_c = 100 μA) (VDC)	80 min.	

DETAILED ELECTRICAL SPECIFICATIONS (-65° to +125°C unless otherwise noted) (Notes 1 & 2)

GENERIC PART NUMBERS	➔	412-5	412-6	412-9	412-12	412-18	412-26	
		412D-5 412DD-5 412T-5	412D-6 412DD-6 412T-6	412D-9 412DD-9 412T-9	412D-12 412DD-12 412T-12	412D-18 412DD-18 412T-18	412D-26 412DD-26 412T-26	
Coil Voltage (VDC)	Nom.	5.0	6.0	9.0	12.0	18.0	26.5	
	Max.	5.8	8.0	12.0	16.0	24.0	32.0	
Coil Resistance (Ohms \pm 10% @ 25°C)	412, 412D, 412T (Note 3)	50	98	220	390	880	1560	
	412DD (Note 3)	39	78	220	390	880	1560	
Coil Current (mADC @ 25°C) (412DD Series)	Min.	93.2	58.3	33.0	25.6	17.5	14.8	
	Max.	128.2	78.3	42.9	32.8	22.1	18.5	
Coil Current (mADC @ 25°C) (412T Series)	(Note 7) Min.	82.2	52.9	35.3	26.6	17.9	14.7	
	Max.	112.1	69.9	47.4	35.8	24.0	19.8	
Pick-up Voltage (VDC, Max.)	412, 412D	3.5	4.5	6.8	9.0	13.5	18.0	
	412DD	3.9	5.2	7.8	10.0	14.5	19.0	
	412T (Note 7)	3.5	4.5	6.8	9.0	13.5	18.0	
Base Current to Turn On (mADC, Max.) (412T Series) (Note 7)		3.00	2.04	1.36	1.03	0.68	0.50	
Drop-out Voltage (VDC)	412, 412D, 412T (Note 7)	Min.	0.14	0.18	0.35	0.41	0.59	0.89
		Max.	2.3	3.2	4.9	6.5	10.0	13.0
	412DD	Min.	0.6	0.7	0.8	0.9	1.1	1.4
		Max.	2.8	3.4	5.3	6.5	10.0	13.0

PERFORMANCE CURVES (NOTE 2)

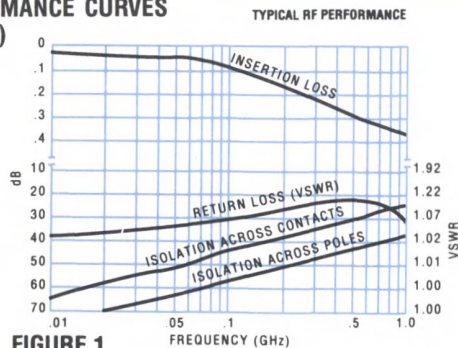

FIGURE 1

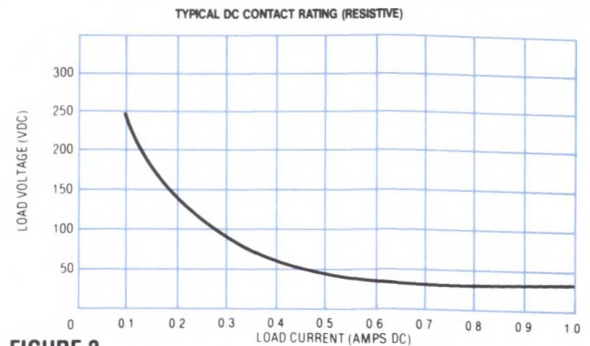
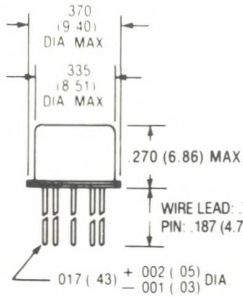
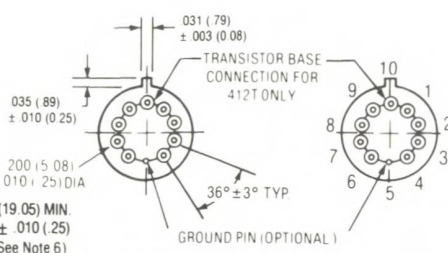

FIGURE 2

OUTLINE DIMENSIONS



TERMINAL LOCATIONS AND PIN NUMBERING (REF. ONLY)
(Viewed from Terminals)



DIMENSIONS ARE SHOWN IN INCHES (MILLIMETERS)

SCHEMATIC DIAGRAMS

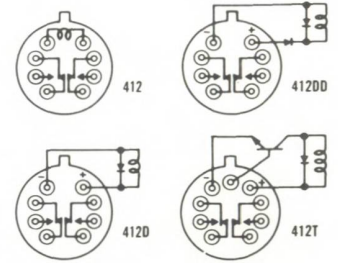

SCHEMATICS ARE VIEWED FROM TERMINALS

SPREADER PADS

Relays can be supplied with spreader pads installed and cemented in place. P/N 192-10 can be used with all 412, 412D, 412DD and 412T Series Relays; P/N 192-59 is limited to 8 pins and therefore will not accommodate the 412T Series Relay. Relays supplied with the 192-59 pad installed have lead trimmed to .130" (3.3mm) ± .010 (.25mm) below pad. To order, add M for the 192-10 pad or M2 for the 192-59 pad to the part number (e.g., 412DM2-26).

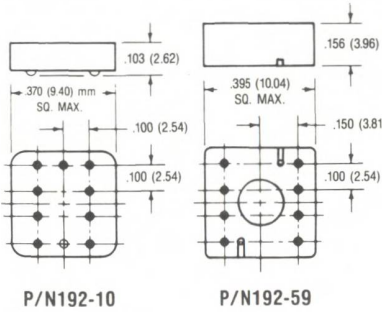

NOTES:

1. Material: Diallyl Phthalate.
2. Add .025 ohm to contact resistance with 192-10 pad; .05 ohm with 192-59 pad.
3. Spreader Pads conform to MIL-M-38527.
4. Leads exit from holes indicated.
5. Tolerance: .XXX = ±.010 (0.25)

TYPICAL TTL INTERFACE CIRCUIT
(See Note 5)

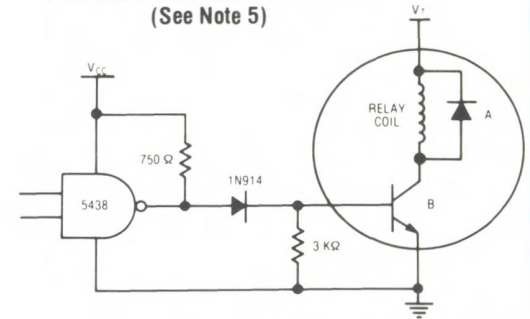

(A) INTERNAL SUPPRESSION DIODE (B) INTERNAL DRIVER TRANSISTOR

MILITARY P/N TO TELEDYNE P/N COMPARISON CHART

REFERENCE M39016/9, /15, /20

REFERENCE M28776/1

SLASH & DASH	TELEDYNE PART NO.*	SLASH & DASH	TELEDYNE PART NO.*	SLASH & DASH	TELEDYNE PART NO.*	SLASH & DASH	TELEDYNE PART NO.*	SLASH & DASH	TELEDYNE PART NO.*	SLASH & DASH	TELEDYNE PART NO.*
/9-013	**	/9-085	412Y-5	/15-036	412DS-9	/15-106	412DM-5	/20-052	412DD-12	/1-013	**
-014	**	-086	-6	-037	-12	/15-113	412YM-6	-053	-18	-014	**
-015	**	-087	-9	-038	-18	-114	-9	-054	-26	-015	**
-016	**	-088	-12	-039	-26	-115	-12	/20-061	412DDM-5	-016	**
-017	**	-089	-18	-040	-5	-116	-18	-062	-6	-017	**
-018	**	-090	-26	/15-065	**	-117	-26	-063	-9	-018	**
-051	**	-091	-30	-066	**	-118	-5	-064	-12	/1-019	412TS-5
/9-019	412S-5	/9-099	412Y-5	-067	**	/15-125	412DM2-6	-065	-18	-020	-6
-020	-6	-100	-6	-068	**	-126	-9	-066	-26	-021	-9
-021	-9	-101	-9	-069	**	-127	-12	/20-073	412DDM2-5	-022	-12
-022	-12	-102	-12	-070	**	-128	-18	-074	-6	-023	-18
-023	-18	-103	-18	/15-077	412D-6	-129	-26	-075	-9	-024	-26
-024	-26	-104	-26	-078	-9	-130	-5	-076	-12	/1-025	412T-5
-052	-30	-105	-30	-079	-12	/20-007	**	-077	-18	-026	-6
/9-057	412-5	/9-106	412M2-5	-080	-18	-008	**	-078	-26	-027	-9
-058	-6	-107	-6	-081	-26	-009	**	/20-079	412DDY-5	-028	-12
-059	-9	-108	-9	-082	-5	-010	**	-080	-6	-029	-18
-060	-12	-109	-12	/15-089	412DY-6	-011	**	-081	-9	-030	-26
-061	-18	-110	-18	-090	-9	-012	**	-082	-12	/1-031	412TM-5
-062	-26	-111	-26	-091	-12	/20-037	412DDS-5	-083	-18	-032	-6
-063	-30	-112	-30	-092	-18	-038	-6	-084	-26	-033	-9
/9-071	412M-5	/15-029	**	-093	-26	-039	-9	/20-091	412DDYM-5	-034	-12
-072	-6	-030	**	-094	-5	-040	-12	-092	-6	-035	-18
-073	-9	-031	**	/15-101	412DM-6	-041	-18	-093	-9	-036	-26
-074	-12	-032	**	-102	-9	-042	-26	-094	-12		
-075	-18	-033	**	-103	-12	/20-049	412DD-5	-095	-18		
-076	-26	-034	**	-104	-18	-050	-6	-096	-26		
-077	-30	/15-035	412DS-6	-105	-26	-051	-9				

*Add reliability level designator A or B. See Teledyne Relays part numbering system and screening and reliability chart (Note 4).
**Not recommended for new design. See Note 6.

NOTES:

1. Relays generally conform to the processes, performance and test requirements of MIL-R-39016 or MIL-R-28776, as applicable. Minor variations in procedures, which do not effect performance or reliability, may be incorporated at the manufacturer's discretion.
2. Performance Characteristics are subject to change beyond those allowed by the applicable Military specification when testing is performed beyond the MIL-R-39016 or MIL-R-28776 rated life. "Typical" characteristics are based on available data and are best estimates. No on-going verification tests are performed.
3. For reference only. Coil resistance not directly measurable at relay terminals due to internal series semiconductor. 412DD and 412T only.
4. Screened hi-rel versions available on special order. Contact factory.
5. Circuit is typical for all 412T Series. Values shown are for 412T-5 relay, and apply over full operating temperature range.
6. Unless otherwise specified, relays are supplied with standard 0.75" (19.05mm) minimum leads. For optional 0.187" (4.75mm) pin versions, add "S" to part number (i.e., 412-5 becomes 412S-5, 412D-5 becomes 412DS-5, etc.).
7. Limit base-emitter current to 15 mADC.

RELIABILITY LEVEL	FAILURE RATE %/10,000 CYCLES
A	3.0
B	1.0

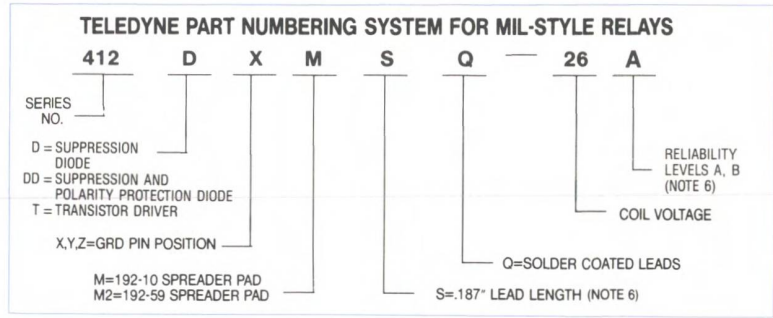

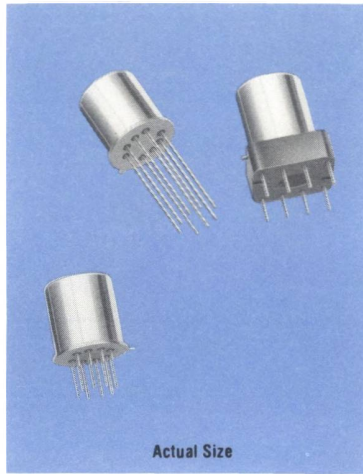

TELEDYNE RELAYS

MILITARY STYLE TO-5 RELAYS

DPDT

SERIES
432



SERIES DESIGNATION	RELAY TYPE
432	DPDT basic relay
432D	DPDT relay with internal diode for coil transient suppression
432DD	DPDT relay with internal diodes for coil transient suppression and polarity reversal protection
432T	DPDT relay with internal transistor driver and coil transient suppression diode

INTERNAL CONSTRUCTION

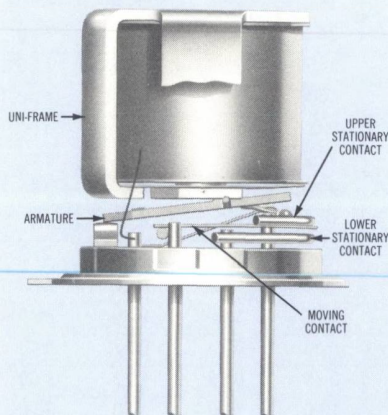

DESCRIPTION

The TO-5 relay, originally conceived and developed by Teledyne, has become the industry standard for low level switching from dry circuit to 1 ampere. Designed expressly for high density PC Board mounting, its small size and low coil power dissipation make the TO-5 relay the most versatile subminiature relay available.

Unique construction features and manufacturing techniques provide excellent resistance to environmental extremes and overall high reliability.

- All welded construction.
- Unique uni-frame design providing high magnetic efficiency and mechanical rigidity.
- High force/mass ratios for resistance to shock and vibration.
- Advanced cleaning and sealing techniques provide maximum assurance of internal cleanliness.
- Precious metal alloy contact material with gold plating assures excellent high current and dry circuit switching capabilities.

The 432D and 432DD Series utilize internal discrete silicon diodes, with characteristics similar to 1N5315. The hybrid 432T Series features a silicon diode and transistor chip (similar to 2N2222A). The integrated packaging of the relay with its associated semi-conductor devices greatly reduces PC Board floor space requirements as well as component installation costs.

By virtue of its inherently low intercontact capacitance and contact circuit losses, the TO-5 relay has proven its worth as an RF switch for frequencies well into the UHF spectrum (see Figure 1). In addition, the sensitive 432 Series relay features exceptionally high coil resistance thus providing for extremely low operating power (200 milliwatts typical at room temperature). The advantages of reduced heat dissipation and power supply demands are obvious.

ENVIRONMENTAL AND PHYSICAL SPECIFICATIONS	
Temperature (Ambient)	-65°C to +125°C
Vibration	30 g's to 3000 Hz (Note 1)
Shock	75 g's for 6 msec. (Note 1) half-sine
Acceleration	75 g's (Note 1)
Enclosure	All welded, hermetically sealed
Weight	0.159 oz. (4.50 gms.) max.

GENERAL ELECTRICAL SPECIFICATIONS (-65°C to +125°C unless otherwise noted) (Notes 1 & 2)

Contact Arrangement	2 Form C (DPDT)	
Rated Duty	Continuous	
Contact Resistance	0.1 ohm max. before life; 0.2 ohm max. after life at 1A/28VDC (measured 1/8" from header)	
Contact Load Ratings (DC) (See Fig. 2 for other DC resistive voltage/current ratings)	Resistive: 1 Amp/28VDC Inductive: 200 mA/28VDC (320 mH) Lamp: 100 mA/28VDC Low Level: 10 to 50 μ A/10 to 50 mV	
Contact Load Ratings (AC)	Resistive: 250 mA/115VAC, 60 and 400Hz (Case not grounded) 100 mA/115VAC, 60 and 400 Hz (Case grounded)	
Contact Life Ratings	10,000,000 cycles (typical) at low level 1,000,000 cycles (typical) at 0.5A/28VDC resistive 100,000 cycles min. at all other loads specified above	
Contact Overload Rating	2A/28VDC Resistive (100 cycles min.)	
Contact Carry Rating	Contact factory	
Coil Operating Power	200 milliwatts typical at nominal rated voltage at 25°C	
Operate Time	4.0 msec. max. at nominal rated coil voltage	
Release Time	432 Series: 2.0 msec. max.	432D, 432DD, 432T Series: 7.5 msec. max.
Contact Bounce	1.5 msec. max.	
Intercontact Capacitance	0.4 pf. typical	
Insulation Resistance	10,000 megohms min. between mutually isolated terminals	
Dielectric Strength	Sea Level: 500 VRMS/60 Hz	70,000 ft.: 125 VRMS/60 Hz
Negative Coil Transient (VDC) 432D, 432DD, 432T	1.0 max.	
Diode P.I.V.(VDC) 432D, 432DD, 432T	100 min.	
432T Transistor Characteristics	Base Turn-Off Voltage (VDC)	0.3 min.
	Emitter-base breakdown Voltage (BV_{EB0}) (@25°C) (VDC)	6.0 min.
	Collector-base breakdown Voltage (BV_{CB0}) (@25°C & I_c = 100μA) (VDC)	80 min.

DETAILED ELECTRICAL SPECIFICATIONS (-65° to +125°C unless otherwise noted) (Notes 1 & 2)

	GENERIC PART NUMBERS	➔	432-5	432-6	432-9	432-12	432-18	432-26	432-36	432-48
			432D-5 432DD-5 432T-5	432D-6 432DD-6 432T-6	432D-9 432DD-9 432T-9	432D-12 432DD-12 432T-12	432D-18 432DD-18 432T-18	432D-26 432DD-26 432T-26	432D-36 432DD-36 432T-36	432D-48 432DD-48 432T-48
Coil Voltage (VDC)	Nom.		5.0	6.0	9.0	12.0	18.0	26.5	36.0	48.0
	Max.		7.5	10.0	15.0	20.0	30.0	40.0	57.0	75.0
Coil Resistance (Ohms \pm 10% at 25°C)	432, 432D, 432T (Note 3)		100	200	400	850	1600	3300	6500	11,000
	432DD (Note 3)		64	125	400	850	1600	3300	6500	11,000
Coil Current (mADC at 25°C) (432DD Series)	(Note 7)	Min.	56.8	36.3	18.1	11.7	9.6	7.0	4.9	3.9
		Max.	78.1	48.9	23.6	15.0	12.2	8.8	6.1	4.8
Coil Current (mADC at 25°C) (432T Series)	(Note 7)	Min.	43.5	26.4	19.7	12.2	9.7	6.9	4.8	3.7
		Max.	59.3	35.4	25.8	16.7	13.1	9.5	6.4	5.1
Pick-up Voltage (VDC, Max.)	432, 432D		3.5	4.5	6.8	9.0	13.5	18.0	27.0	36.0
	432DD		3.7	4.8	8.0	11.0	14.5	19.0	27.2	34.8
	432T (Note 7)		3.6	4.8	7.8	11.0	14.5	19.0	27.0	36.0
Base Current to Turn On (mADC, Max.) (432T Series) (Note 7)			1.50	1.00	0.75	0.47	0.38	0.24	0.17	0.13
Drop-out Voltage (VDC)	432, 432D, 432T (Note 7)	Min.	0.14	0.18	0.35	0.41	0.59	0.89	1.25	1.60
		Max.	2.5	3.2	4.9	6.5	10.0	13.0	19.0	26.0
	432DD	Min.	0.7	0.8	0.9	1.0	1.1	1.3	1.7	2.0
		Max.	2.6	3.0	4.5	5.8	9.0	13.0	19.0	26.0

PERFORMANCE CURVES (NOTE 2)

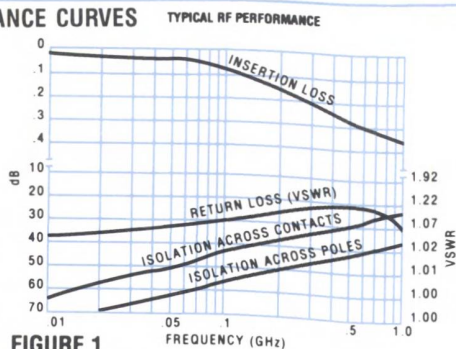

FIGURE 1

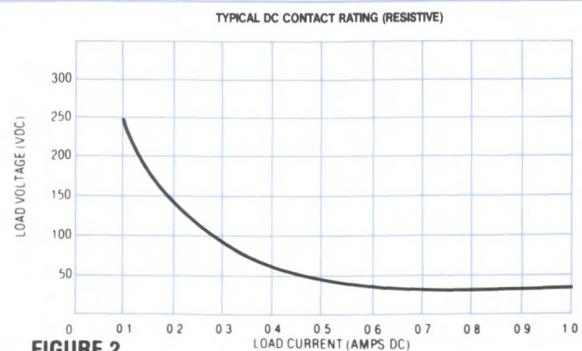
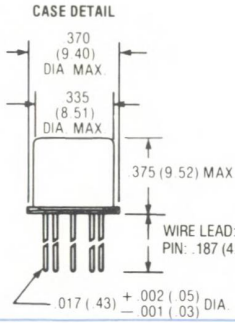
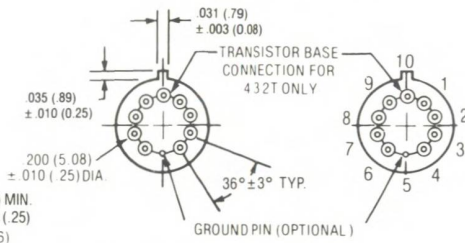

FIGURE 2

OUTLINE DIMENSIONS



TERMINAL LOCATIONS AND PIN NUMBERING (REF. ONLY)
(Viewed from Terminals)



DIMENSIONS ARE SHOWN IN INCHES (MILLIMETERS)

SCHEMATIC DIAGRAMS

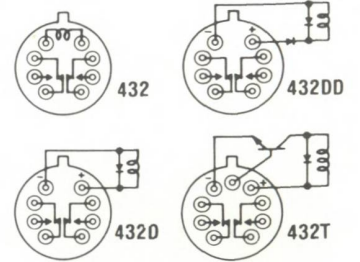

SCHEMATICS ARE VIEWED FROM TERMINALS

SPREADER PADS

Relays can be supplied with spreader pads installed and cemented in place. P/N 192-10 can be used with all 432, 432D, 432DD and 432T Series Relays; P/N 192-59 is limited to 8 pins and therefore will not accommodate the 432T Series Relay. Relays supplied with the 192-59 pad installed have leads trimmed to .130 in. (3.3mm) ± .010 (.25mm) below pad. To order, add M for the 192-10 pad or M2 for the 192-59 pad to the part number (e.g., 432DM2-26).

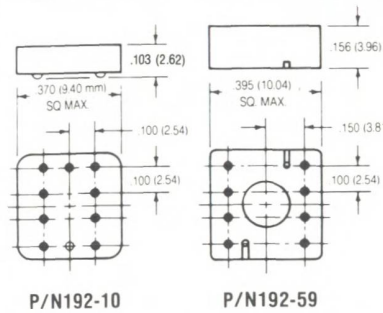

NOTES:

1. Material: Diallyl Phthalate.
2. Add .025 ohm to contact resistance with 192-10 pad; .05 ohm with 192-59 pad.

3. Spreader Pads conform to MIL-M-38527.
4. Leads exit from holes indicated.
5. Tolerance: .XXX = ± .010 (0.25)

TYPICAL TTL INTERFACE CIRCUIT
(See Note 5)

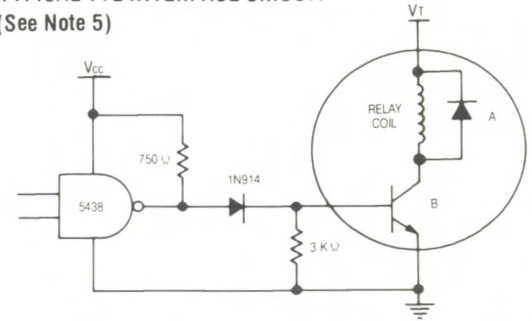

(A) INTERNAL SUPPRESSION DIODE (B) INTERNAL DRIVER TRANSISTOR

MILITARY P/N TO TELEDYNE P/N COMPARISON CHART

REFERENCE M39016/11, /16, /21

REFERENCE M28776/3

SLASH & DASH	TELEDYNE PART NO.*	SLASH & DASH	TELEDYNE PART NO.*	SLASH & DASH	TELEDYNE PART NO.*	SLASH & DASH	TELEDYNE PART NO.*	SLASH & DASH	TELEDYNE PART NO.*	SLASH & DASH	TELEDYNE PART NO.*
/11-017	**	/11-041	432M-5	/16-033	432D-5	/21-019	432DD-5	/3-017	**	/3-041	432TM-5
-019	**	-042	-6	-034	-6	-020	-6	-018	**	-042	-6
-021	**	-043	-12	-035	-12	-021	-9	-019	**	-043	-9
-023	**	-044	-26	-036	-26	-022	-12	-020	**	-044	-12
-025	**	-045	-36	-037	-36	-023	-18	-021	**	-045	-18
-027	**	-046	-48	-038	-48	-024	-26	-022	**	-046	-26
-029	**	-047	-9	-039	-9	-031	-36	-023	**	-047	-36
-031	**	-048	-18	-040	-18	-032	-48	-024	**	-048	-48
/11-018	432S-5	/16-017	**	/16-041	432DM-5	/21-033	432DD-5	/3-025	432TS-5		
-020	-6	-018	**	-042	-6	-034	-6	-026	-6		
-022	-12	-019	**	-043	-12	-035	-9	-027	-9		
-024	-26	-020	**	-044	-26	-036	-12	-028	-12		
-026	-36	-021	**	-045	-36	-037	-18	-029	-18		
-028	-48	-022	**	-046	-48	-038	-26	-030	-26		
-030	-9	-023	**	-047	-9	-039	-36	-031	-36		
-032	-18	-024	**	-048	-18	-040	-48	-032	-48		
/11-033	432S-5	/16-025	432DS-5	/21-007	**	/21-041	432DDM-5	/3-033	432T-5		
-034	-6	-026	-6	-008	**	-042	-6	-034	-6		
-035	-12	-027	-12	-009	**	-043	-9	-035	-9		
-036	-26	-028	-26	-010	**	-044	-12	-036	-12		
-037	-36	-029	-36	-011	**	-045	-18	-037	-18		
-038	-48	-030	-48	-012	**	-046	-26	-038	-26		
-039	-9	-031	-9	-029	**	-047	-36	-039	-36		
-040	-12	-032	-18	-030	**	-048	-48	-040	-48		

*Add reliability level designator A or B. See Teledyne Relays part numbering system and screening and reliability chart (Note 4).

**Not recommended for new design. See Note 6.

NOTES:

1. Relays generally conform to the processes, performance and test requirements of MIL-R-39016 or MIL-R-28776, as applicable. Minor variations in procedures, which do not effect performance or reliability, may be incorporated at the manufacturer's discretion.
2. Performance Characteristics are subject to change beyond those allowed by the applicable Military specification when testing is performed beyond the MIL-R-39016 or MIL-R-28776 rated life. "Typical" characteristics are based on available data and are best estimates. No on-going verification tests are performed.
3. For reference only. Coil resistance not directly measurable at relay terminals due to internal series semiconductor. 432DD and 432T only.
4. Screened hi-rel versions available on special order. Contact factory.
5. Circuit is typical for all 432T Series. Values shown are for 432T-5 relay, and apply over full operating temperature range.
6. Unless otherwise specified, relays are supplied with standard 0.75" (19.05mm) minimum leads. For optional 0.187" (4.75mm) pin versions, add 'S' to part number (i.e., 432S-5 becomes 432DS-5, etc.).
7. Limit base-emitter current to 15 mADC.

RELIABILITY LEVEL	FAILURE RATE %/10,000 CYCLES
A	3.0
B	1.0

TELEDYNE PART NUMBERING SYSTEM FOR MIL-STYLE RELAYS

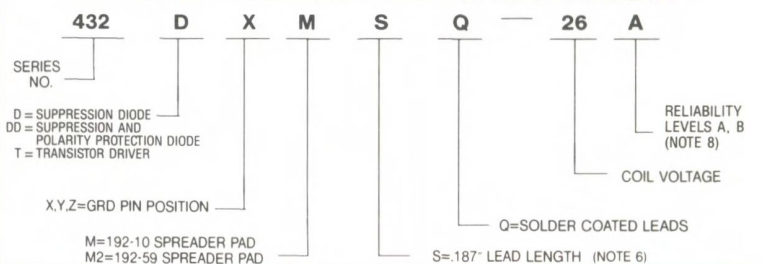

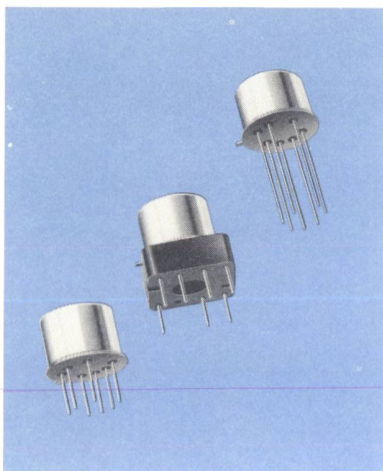

TELEDYNE RELAYS

MILITARY STYLE TO-5 RELAYS

SPDT MAGNETIC LATCHING

SERIES
421



SERIES DESIGNATION	RELAY TYPE
421	SPDT basic relay
421D	SPDT relay with internal diode for coil transient suppression
421DD	SPDT relay with internal diodes for coil transient suppression and polarity reversal protection

DESCRIPTION

The TO-5 relay, originally conceived and developed by Teledyne, has become the industry standard for low level switching from dry circuit to 0.5 ampere. Designed expressly for high density PC Board mounting, its small size and low coil power dissipation make the TO-5 relay the most versatile subminiature relay available.

Unique construction features and manufacturing techniques provide excellent resistance to environmental extremes and overall high reliability.

- All welded construction.
- Unique uni-frame design providing high magnetic efficiency and mechanical rigidity.
- High force/mass ratios for resistance to shock and vibration.
- Advanced cleaning and sealing techniques provide maximum assurance of internal cleanliness.
- Precious metal alloy contact material with gold plating assures excellent high current and dry circuit switching capabilities.

The 421D and 421DD Series utilize internal discrete silicon diodes, with characteristics similar to 1N5315.

By virtue of its inherently low intercontact capacitance and contact circuit losses, the TO-5 relay has proven to be an excellent subminiature RF switch for frequency ranges well into the UHF spectrum. A typical RF application for the TO-5 relay is in hand held radio transceivers, wherein the combined features of good RF performance, small size, low coil power dissipation and high reliability make it the preferred relay for Transmitter-Receiver switching (see Figure 1).

The 421 Series magnetic latching relays are ideally suited for applications where power dissipation must be minimized. The relays can be operated with a short duration pulse. After contacts have transferred, no holding power is required.

The magnetic latching feature of the 421 Series provides a "memory" capability, since the relays will not reset upon removal of power.

PRINCIPLE OF OPERATION

Energizing Coil B produces a magnetic field opposing the holding flux of the permanent magnet in Circuit B. As this net holding force decreases, the attractive force in the air gap of Circuit A, which also results from the flux of the permanent magnet, becomes great enough to break the armature free of Core B, and snap it into a closed position against Core A. The armature then remains in this position upon removal of power from Coil B, but will snap back into position B upon energizing Coil A. Since operation depends upon cancellation of a magnetic field, it is necessary to apply the correct polarity to the relay coils as indicated on the relay schematic.

When latching relays are installed in equipment, the latch and reset coils should not be pulsed simultaneously. Coils should not be pulsed with less than the nominal coil voltage and the pulse width should be a minimum of three times the specified operate time of the relay. If these conditions are not followed, it is possible for the relay to be in the magnetically neutral position.

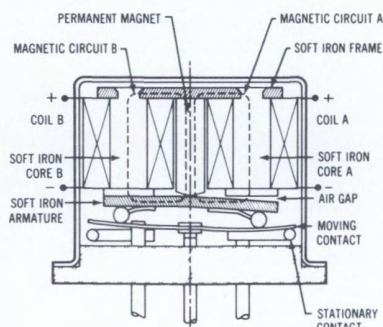

ENVIRONMENTAL AND PHYSICAL SPECIFICATIONS

Temperature (Ambient)	-65°C to +125°C
Vibration	30 g's to 3000 Hz (Note 1)
Shock	100 g's for 6 msec. (Note 1) half-sine
Acceleration	75 g's (Note 1)
Enclosure	All welded, hermetically sealed
Weight	0.089 oz. (2.52 gms.) max.

GENERAL ELECTRICAL SPECIFICATIONS (-65°C to +125°C unless otherwise noted) (Notes 1 & 2)

Contact Arrangement	1 Form C (SPDT)	
Rated Duty	Continuous	
Contact Resistance	0.125 ohm max. before life; 0.225 ohm max. after life at 0.5A/28VDC (measured 1/8" from header)	
Contact Load Ratings (DC) (See Fig. 2 for other DC resistive voltage/current ratings)	Resistive: 1 Amp/28VDC Inductive: 200 mA/28VDC (320 mH) Lamp: 100 mA/28VDC Low Level: 10 to 50 μ A/10 to 50 mV	
Contact Load Ratings (AC)	Resistive: 250 mA/115VAC, 60 and 400Hz (Case not grounded) 100 mA/115VAC, 60Hz and 400Hz (Case grounded)	
Contact Life Ratings	10,000,000 cycles (typical) at low level 100,000 cycles min. at all other loads specified above	
Contact Overload Rating	1A/28VDC Resistive (100 cycles min.)	
Contact Carry Rating	Contact factory	
Coil Operating Power	290 milliwatts typical at nominal rated voltage at 25°C	
Operate Time	1.5 msec. max. at nominal rated coil voltage	
Contact Bounce	1.5 msec. max.	
Minimum Operate Pulse	4.5 msec. @ nominal voltage	
Intercontact Capacitance	0.4 pf. typical	
Insulation Resistance	10,000 megohms min. between mutually isolated terminals	
Dielectric Strength	Sea level: 500 VRMS/60 Hz.	70,000 ft.: 125 VRMS/60 Hz.
Diode P.I.V. 421D,421DD	100 VDC, min.	
Negative Coil Transient 421D,421DD	1.0 VDC max.	

DETAILED ELECTRICAL SPECIFICATIONS (-65°C to +125°C unless otherwise noted) (Notes 1 & 2)

	GENERIC PART NUMBERS	➔	421-5	421-6	421-9	421-12	421-18	421-26
			421D-5 421DD-5	421D-6 421DD-6	421D-9 421DD-9	421D-12 421DD-12	421D-18 421DD-18	421D-26 421DD-26
Coil Voltage (VDC)	Nom.		5.0	6.0	9.0	12.0	18.0	26.5
	Max.		6.0	8.0	12.0	16.0	24.0	32.0
Coil Resistance (Ohms \pm 10% @25°C)	421,421D		61	120	280	500	1130	2000
	421DD (Note 3)		48	97	280	500	1130	2000
Coil Current (mADC @ 25°C) 421DD Series only	Min.		78.0	45.8	25.7	19.6	13.4	11.2
	Max.		111.8	63.0	34.9	26.7	18.8	15.2
Set & Reset Voltage (VDC, Max.)	421		3.5	4.5	6.8	9.0	13.5	18.0
	421D		3.7	4.5	6.8	9.0	13.5	18.0
	421DD		4.5	5.5	7.8	10.0	14.5	19.0

PERFORMANCE CURVES (NOTE 2)

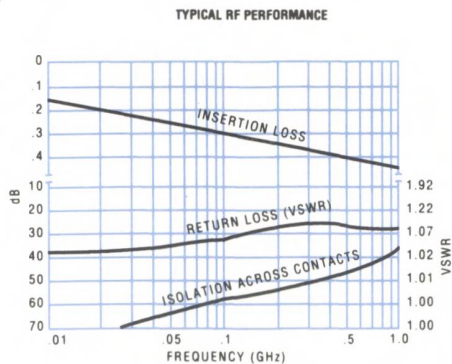

FIGURE 1

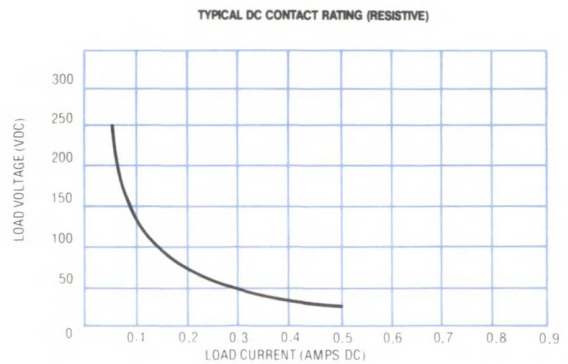
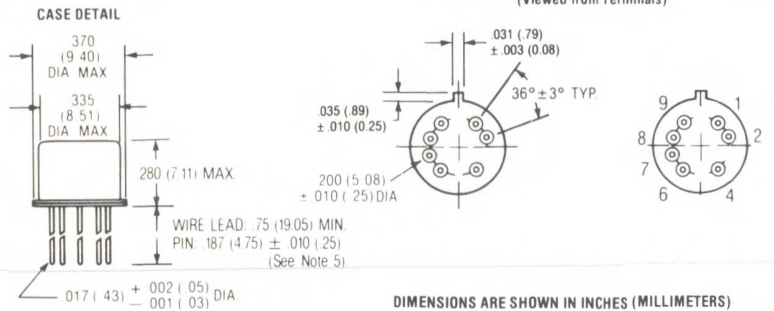

FIGURE 2

OUTLINE DRAWINGS



DIMENSIONS ARE SHOWN IN INCHES (MILLIMETERS)

SPREADER PADS

Relays can be supplied with spreader pads installed and cemented in place. Relays supplied with 192-59 pad installed have leads trimmed to .130 in. (.3.3mm) ± .010 (.25mm) below pad. To order, add M for the 192-10 pad or M2 for the 192-59 pad to the part number (e.g., 421DM2-26).

NOTES:

1. Material: Diallyl phthalate.
2. Add .025 ohm to contact resistance with 192-10 pad; .05 ohm with 192-59 pad.
3. Spreader pads conform to MIL-M-38527.
4. Leads exit from holes indicated.
5. Tolerance: .XXX = ± .010 (0.25)

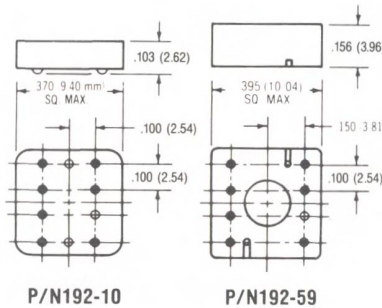

SCHEMATIC DIAGRAMS

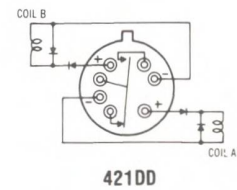
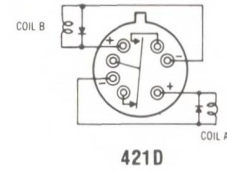
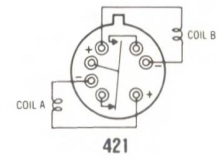

SCHEMATICS ARE VIEWED FROM TERMINALS
COIL A LAST ENERGIZED

MILITARY P/N TO TELEDYNE P/N COMPARISON CHART
REFERENCE M39016/8, /27, /28

SLASH & DASH	TELEDYNE PART NO.*	SLASH & DASH	TELEDYNE PART NO.*	SLASH & DASH	TELEDYNE PART NO.*	SLASH & DASH	TELEDYNE PART NO.*
/8-013	**	/8-031	421M-5	/27-025	421D-5	/28-019	421DDS-5
-015	**	-032	-6	-026	-6	-020	-6
-017	**	-033	-9	-027	-9	-021	-9
-019	**	-034	-12	-028	-12	-022	-12
-021	**	-035	-18	-029	-18	-023	-18
-023	**	-036	-26	-030	-26	-024	-26
/8-014	421S-5	/27-013	**	/27-031	421DM-5	/28-025	421DD-5
-016	-6	-014	**	-032	-6	-026	-6
-018	-9	-015	**	-033	-9	-027	-9
-020	-12	-016	**	-034	-12	-028	-12
-022	-18	-017	**	-035	-18	-029	-18
-024	-26	-018	**	-036	-26	-030	-26
/8-025	421-5	/27-019	421DS-5	/28-013	**	/28-031	421DDM-5
-026	-6	-020	-6	-014	**	-032	-6
-027	-9	-021	-9	-015	**	-033	-9
-028	-12	-022	-12	-016	**	-034	-12
-029	-18	-023	-18	-017	**	-035	-18
-030	-26	-024	-26	-018	**	-036	-26

*Add reliability level designator A or B. See Teledyne Relays part numbering system and screening and reliability chart (Note 4).
**Not recommended for new design. See Note 5.

NOTES:

1. Relays generally conform to the processes, performance and test requirements of MIL-R-39016. Minor variations in procedures, which do not effect performance or reliability, may be incorporated at the manufacturer's discretion.
2. Performance Characteristics are subject to change beyond those allowed by the applicable Military specification when testing is performed beyond the MIL-R-39016 rated life. "Typical" characteristics are based on available data and are best estimates. No on-going verification tests are performed.
3. For reference only. Coil resistance not directly measurable at relay terminals due to internal series semiconductor. 421DD only.
4. Screened hi-rel versions available on special order. Contact factory.
5. Unless otherwise specified, relays are supplied with standard 0.75" (19.05mm) minimum leads. For optional 0.187" (4.75mm) pin versions, add "S" to part number (i.e., 421-5 becomes 421S-5. 421D-5 becomes 421DS-5, etc.).

RELIABILITY LEVEL	FAILURE RATE %/10,000 CYCLES
A	3.0
B	1.0

TELEDYNE PART NUMBERING SYSTEM FOR MIL-STYLE RELAYS

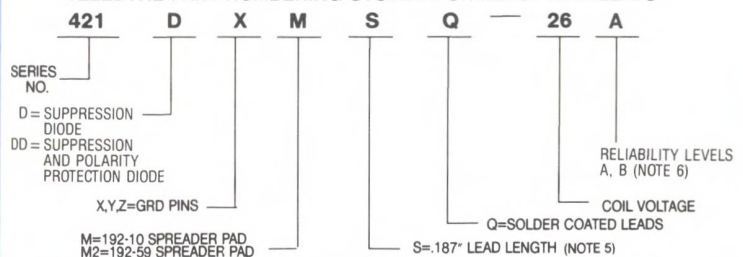

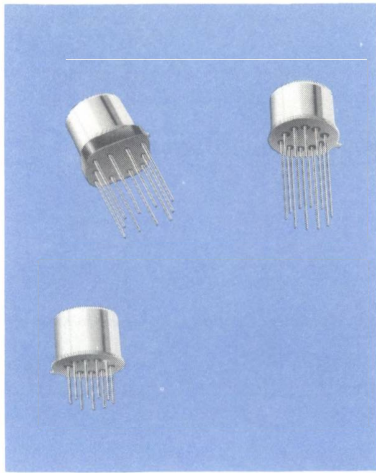

TELEDYNE RELAYS

MAGNETIC LATCHING MILITARY STYLE TO-5 RELAY DPDT

SERIES
420/422



SERIES DESIGNATION	RELAY TYPE
420/422	DPDT basic relay
420D/422D	DPDT relay with internal diode for coil transient suppression
420DD/422DD	DPDT relay with internal diodes for coil transient suppression and polarity reversal protection

DESCRIPTION

The TO-5 relay, originally conceived and developed by Teledyne, has become the industry standard for low level switching from dry circuit to 1 ampere. Designed expressly for high density PC Board mounting, its small size and low coil power dissipation make the TO-5 relay the most versatile subminiature relay available.

Unique construction features and manufacturing techniques provide excellent resistance to environmental extremes and overall high reliability.

- All welded construction.
- Unique uni-frame design providing high magnetic efficiency and mechanical rigidity.
- High force/mass ratios for resistance to shock and vibration.
- Advanced cleaning and sealing techniques provide maximum assurance of internal cleanliness.
- Precious metal alloy contact material with gold plating assures excellent high current and dry circuit switching capabilities.

The 420D/422D and 420DD/422DD Series utilize discrete silicon diodes, with characteristics similar to 1N5315.

By virtue of its inherently low intercontact capacitance and contact circuit losses, the TO-5 relay has proven to be an excellent subminiature RF switch for frequency ranges well into the UHF spectrum. A typical RF application for the TO-5 relay is in hand held radio receivers, wherein the combined features of good RF performance, small size, low coil power dissipation and high reliability make it the preferred relay for transmitter-receiver switching (See Figure 1).

The 420/422 Series magnetic latching relays are ideally suited for applications where power dissipation must be minimized. The relays can be operated with a short duration pulse. After contacts have transferred, no holding power is required.

The magnetic latching feature of the 420/422 Series provides a 'memory' capability, since the relays will not reset upon removal of power.

PRINCIPLE OF OPERATION

Energizing Coil B produces a magnetic field opposing the holding flux of the permanent magnet in Circuit B. As this net holding force decreases, the attractive force in the air gap of Circuit A, which also results from the flux of the permanent magnet, becomes great enough to break the armature free of Core B, and snap it into a closed position against Core A. The armature then remains in this position upon removal of power from Coil B, but will snap back to position B upon energizing Coil A. Since operation depends upon cancellation of a magnetic field, it is necessary to apply the correct polarity to the relay coils as indicated on the relay schematic.

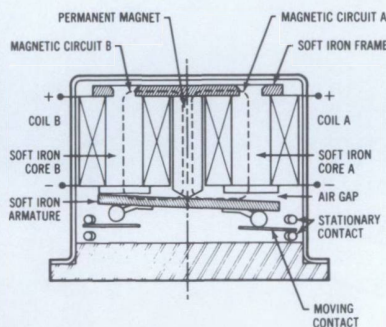

When latching relays are installed in equipment, the latch and reset coils should not be pulsed simultaneously. Coils should not be pulsed with less than the nominal coil voltage and the pulse width should be a minimum of three times the specified operate time of the relay. If these conditions are not followed, it is possible for the relay to be in the magnetically neutral position.

ENVIRONMENTAL AND PHYSICAL SPECIFICATIONS

Temperature (Ambient)	-65°C to +125°C
Vibration	30 g's to 3000 Hz (Note 1)
Shock	100 g's for 6 msec. (Note 1) half-sine
Acceleration	75 g's (Note 1)
Enclosure	All welded, hermetically sealed
Weight	0.10 oz. (2.84 gms.) max.

SERIES 420/422

GENERAL ELECTRICAL SPECIFICATIONS (-65°C to +125°C unless otherwise noted) (Notes 1 & 2)

Contact Arrangement	2 Form C (DPDT)	
Rated Duty	Continuous	
Contact Resistance	0.125 ohm max. before life; 0.225 ohm max. after life at 1A/28VDC (measured 1/8" from header)	
Contact Load Ratings (DC) (See Fig. 2 for other DC resistive voltage/current ratings)	Resistive: 1 Amp/28VDC Inductive: 200 mA/28VDC (320 mH) Lamp: 100 mA/28VDC Low Level: 10 to 50 μ A/10 to 50 mV	
Contact Load Ratings (AC)	Resistive: 250 mA/115VAC, 60 and 400Hz (Case not grounded) 100 mA/115VAC, 60 and 400 Hz (Case grounded)	
Contact Life Ratings	10,000,000 cycles (typical) at low level 1,000,000 cycles (typical) at 0.5A/28VDC resistive 100,000 cycles min. at all other loads specified above	
Contact Overload Rating	2A/28VDC Resistive (100 cycles min.)	
Contact Carry Rating	Contact factory	
Coil Operating Power	290 milliwatts typical at nominal rated voltage at 25°C	
Operate Time	420/422, 420D/422D	1.5 msec. max. at nominal rated coil voltage
	420DD/422DD	2.0 msec. max. at nominal rated coil voltage
Contact Bounce	2.0 msec. max.	
Minimum Operate Pulse	4.5 msec. at nominal voltage	
Intercontact Capacitance	0.4 pf. typical	
Insulation Resistance	10,000 megohms min. between mutually isolated terminals	
Dielectric Strength	Sea level: 500 VRMS/60 Hz.	70,000 ft.: 125 VRMS/60 Hz.
Diode P.I.V. 420D/422D, 420DD/422DD	100 VDC, min.	
Negative Coil Transient 420D/422D, 420DD/422DD	1.0 VDC max.	

DETAILED ELECTRICAL SPECIFICATIONS (-65° to +125°C unless otherwise noted) (Notes 1 & 2)

	GENERIC PART NUMBERS	420/422-5	420/422-6	420/422-9	420/422-12	420/422-18	420/422-26
		420D/422D-5 420DD/422DD-5	420D/422D-6 420DD/422DD-6	420D/422D-9 420DD/422DD-9	420D/422D-12 420DD/422DD-12	420D/422D-18 420DD/422DD-18	420D/422D-26 420DD/422DD-26
Coil Voltage (VDC)	Nom.	5.0	6.0	9.0	12.0	18.0	26.5
	Max.	6.0	8.0	12.0	16.0	24.0	32.0
Coil Resistance (Ohms \pm 10% @ 25°C)	420/422, 420D/422D	61	120	280	500	1130	2000
	420DD/422DD (See Note 3)	48	97	280	500	1130	2000
Coil Current (mA DC AT 25°C) 420DD/422DD only	Min.	75.8	46.9	26.0	20.0	13.7	11.6
	Max.	104.2	63.0	33.7	25.5	17.2	14.4
Set & Reset Voltage (VDC, Max.)	420/422						
	420D/422D	3.5	4.5	6.8	9.0	13.5	18.0
	420DD/422DD	4.5	5.5	7.8	10.0	14.5	19.0

**PERFORMANCE CURVES
(NOTE 2)**

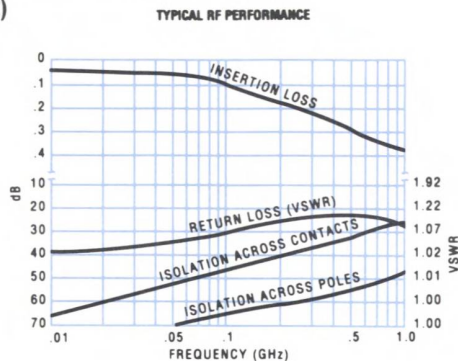

FIGURE 1

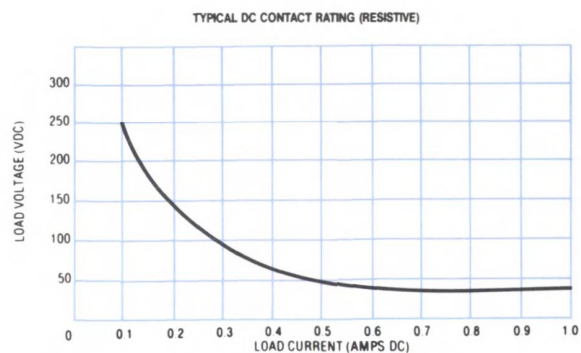
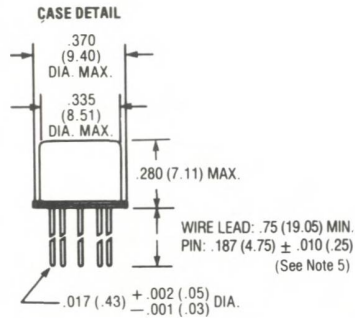
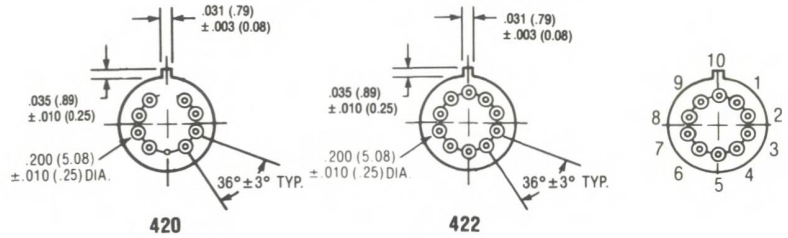

FIGURE 2

OUTLINE DIMENSIONS



TERMINAL LOCATIONS AND PIN NUMBERING (REF. ONLY)
(Viewed from Terminals)



DIMENSIONS ARE SHOWN IN INCHES (MILLIMETERS)

SPREADER PADS

Relays can be supplied with a spreader pad installed and cemented in place. To order, add M for the 192-10 pad to the part number (e.g. 420DM-26).

NOTES:

1. Material; Diallyl phthalate.
2. Add .025 ohm to contact resistance with 192-10 pad.
3. Spreader Pads conform to MIL-M-38527.
4. Leads exit from holes indicated.
5. Tolerance: .XXX = ±.010 (0.25)

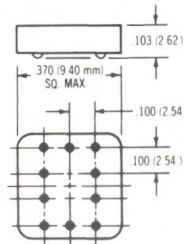

P/N192-10

SCHEMATIC DIAGRAMS

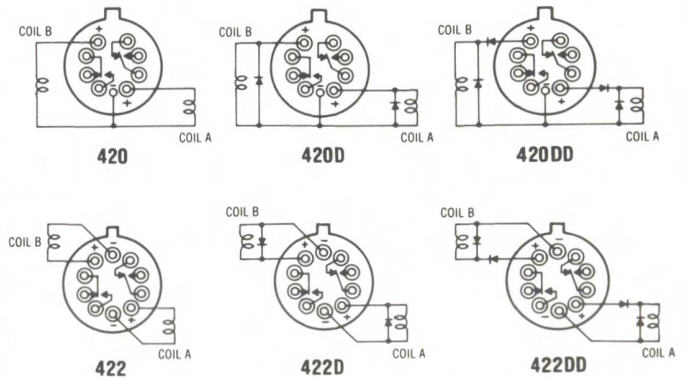

SCHEMATICS ARE VIEWED FROM TERMINALS.
CONTACTS SHOWN IN POSITION RESULTING WHEN COIL A LAST ENERGIZED.

MILITARY P/N TO TELEDYNE P/N COMPARISON CHART

REFERENCE M39016/12, /29, /30

SLASH & DASH	TELEDYNE PART NO.*	SLASH & DASH	TELEDYNE PART NO.*	SLASH & DASH	TELEDYNE PART NO.*	SLASH & DASH	TELEDYNE PART NO.*	SLASH & DASH	TELEDYNE PART NO.*	SLASH & DASH	TELEDYNE PART NO.*
/12-025	**	/12-055	422-5	/29-031	**	/29-061	420DM-6	/30-037	420DD-6	/30-067	422DDM-5
-026	**	-056	-6	-032	**	-062	-9	-038	-9	-068	-6
-027	**	-057	-9	-033	**	-063	-12	-039	-12	-069	-9
-028	**	-058	-12	-034	**	-064	-18	-040	-18	-070	-12
-029	**	-059	-18	-035	**	-065	-26	-041	-26	-071	-18
-030	**	-060	-26	-036	**	-066	-5	-042	-5	-072	-26
/12-031	**	/12-061	420M-5	/29-037	420DS-6	/29-067	422DM-5	/30-043	422DD-5	/30-073	422DDX-12
-032	**	-062	-6	-038	-9	-068	-6	-044	-6	-074	-5
-033	**	-063	-9	-039	-12	-069	-9	-045	-9	-075	-6
-034	**	-064	-12	-040	-18	-070	-12	-046	-12	-076	-9
-035	**	-065	-18	-041	-26	-071	-18	-047	-18	-077	-18
-036	**	-066	-26	-042	-5	-072	-26	-048	-26	-078	-26
/12-037	420S-5	/12-067	422M-5	/29-043	422DS-5	/29-073	422DX-12	/30-049	420DD-6		
-038	-6	-068	-6	-044	-6	-074	-5	-050	-9		
-039	-9	-069	-9	-045	-9	-075	-6	-051	-12		
-040	-12	-070	-12	-046	-12	-076	-9	-052	-18		
-041	-18	-071	-18	-047	-18	-077	-18	-053	-26		
-042	-26	-072	-26	-048	-26	-078	-26	-054	-5		
/12-043	422S-5	/12-073	422X-5	/29-049	420D-6	/30-025	**	/30-055	422DD-5		
-044	-6	-074	-6	-050	-9	-026	**	-056	-6		
-045	-9	-075	-9	-051	-12	-027	**	-057	-9		
-046	-12	-076	-12	-052	-18	-028	**	-058	-12		
-047	-18	-077	-18	-053	-26	-029	**	-059	-18		
-048	-26	-078	-26	-054	-5	-030	**	-060	-26		
/12-049	420-5	/29-025	**	/29-055	422D-5	/30-031	**	/30-061	420DDM-6		
-050	-6	-026	**	-056	-6	-032	**	-062	-9		
-051	-9	-027	**	-057	-9	-033	**	-063	-12		
-052	-12	-028	**	-058	-12	-034	**	-064	-18		
-053	-18	-029	**	-059	-18	-035	**	-065	-26		
-054	-26	-030	**	-060	-26	-036	**	-066	-5		

*Add reliability level designator A or B. See Teledyne Relays part numbering system and screening and reliability chart (Note 4).

**Not recommended for new design. See Note 5.

NOTES:

1. Relays generally conform to the processes, performance and test requirements of MIL-R-39016. Minor variations in procedures, which do not effect performance or reliability, may be incorporated at the manufacturer's discretion.
2. Performance Characteristics are subject to change beyond those allowed by the Military specification when testing is performed beyond the MIL-R-39016 rated life. "Typical" characteristics are based on available data and are best estimates. No on-going verification tests are performed.
3. For reference only. Coil resistance not directly measurable at relay terminals due to internal series semiconductor. 420DD and 422DD only.
4. Screened hi-rel versions available on special order. Contact factory.
5. Unless otherwise specified, relays are supplied with standard 0.75" (19.05mm) minimum leads. For optional 0.187" (4.75mm) pin versions, add "S" to part number (i.e., 422-5 becomes 422S-5, 422DS-5, etc.).

RELIABILITY LEVEL	FAILURE RATE %/10,000 CYCLES
A	3.0
B	1.0

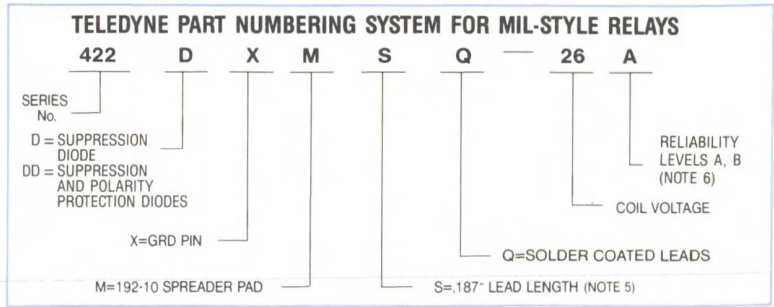

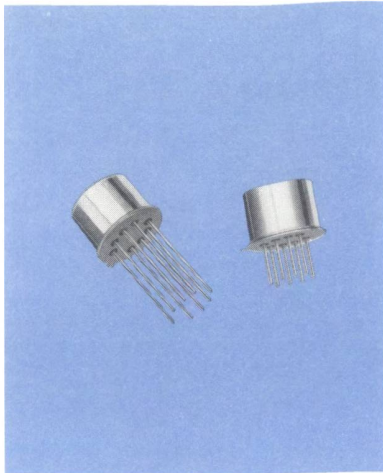

TELEDYNE RELAYS

HIGH TEMPERATURE (200°) MILITARY STYLE TO-5 RELAY DPDT

**SERIES
412H
422H
432H**

SERIES DESIGNATION	RELAY TYPE
412H	DPDT high temperature relay
422H	DPDT high temperature magnetic latching relay
432H	DPDT sensitive high temperature relay

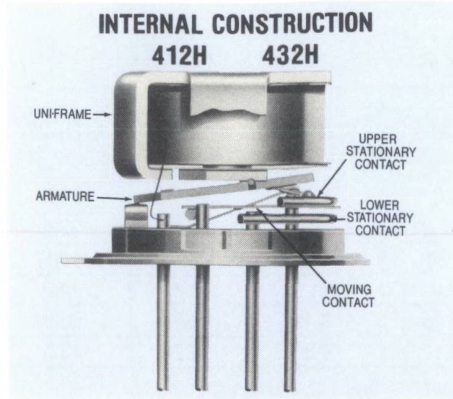

412H ENVIRONMENTAL AND 432H PHYSICAL SPECIFICATIONS	
Temperature (Ambient)	-65°C to +200°C
Vibration	30 g's to 3000 Hz (Note 3)
Shock	75 g's 6 msec. (Note 3) half-sine
Acceleration	75 g's (Note 3)
Enclosure	All welded, hermetically sealed
Weight	412H: 0.09 oz. (2.55 gms.) max. 432H: 0.15 oz. (4.25 gms.) max.

422H ENVIRONMENTAL AND PHYSICAL SPECIFICATIONS	
Temperature (Ambient)	-65°C to +200°C
Vibration	30 g's to 3000 Hz (Note 3)
Shock	100 g's 6 msec. (Note 3) half-sine
Acceleration	75 g's (Note 3)
Weight	0.10 oz. (2.84 gms.) max.

DESCRIPTION

The TO-5 relay, originally conceived and developed by Teledyne, has become the industry standard for low level switching from dry circuit to 1 ampere. Designed expressly for high density PC Board mounting, its small size and low coil dissipation make the TO-5 relay the most versatile subminiature relay available.

The High Temperature Series of TO-5 Relays are designed for reliable operation in elevated ambient temperatures up to 200°C. Special material selection and processing provide assurance of freedom from contact contamination and mechanical malfunctioning that might otherwise be caused by ambient temperature conditions in excess of maximum military temperature limits:

Typical applications are:

- Aircraft avionics and control systems
- Missile control systems
- Spaceflight systems
- Oil exploration (down hole) instrumentation
- High Temperature industrial and process control instrumentation

By virtue of its inherently low intercontact capacitance and contact circuit losses, the TO-5 relay has proven to be an excellent subminiature RF switch for frequency ranges well into the UHF spectrum. (see Figure 1 and 2).

PRINCIPLE OF OPERATION 422H

Energizing Coil B produces a magnetic field opposing the holding flux of the permanent magnet in Circuit B. As this net holding force decreases, the attractive force in the air gap of circuit A, which also results from the flux of the permanent magnet, becomes great enough to break the armature free of Core B, and snap it into a closed position against Core A. The armature then remains in this position upon removal of power from Coil B, but will snap back to position B upon energizing Coil A. Since operation depends upon cancellation of a magnetic field, it is necessary to apply the correct polarity to the relay coils as indicated on the relay schematic.

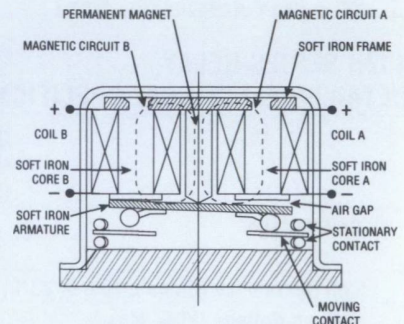

When latching relays are installed in equipment, the latch and reset coils should not be pulsed simultaneously. Coils should not be pulsed with less than the nominal coil voltage and the pulse width should be a minimum of three times the specified operate time of the relay. If these conditions are not followed, it is possible for the relay to be in the magnetically neutral position.

SERIES 412H/422H/432H

GENERAL ELECTRICAL SPECIFICATIONS (-65°C to + 200°C unless otherwise noted) (NOTES 1 AND 2)

Contact Arrangement	2 Form C (DPDT)		
Rated Duty	Continuous		
Contact Resistance	412H/432H: 0.125 ohms max. before life; 0.225 ohms max. after life @ 1A/28VDC, 422H: 0.15 ohms max. before life; .25 ohms max. after life/1A/28VDC } (measured 1/8" below header)		
Contact Load Rating (DC) (See Fig. 3 for other DC resistive voltage/current ratings)	Resistive: 1 Amp/28VDC Inductive: 200 mA/28VDC (320 mH) Lamp: 100 mA/28VDC Low Level: 10 to 50µA/10 to 50 mV		
Contact Load Ratings (AC) (Note8)	Resistive: 250 mA/115VAC, 60 and 400 Hz (Case not grounded) 100 mA/115VAC, 60 and 400 Hz, (Case grounded)		
Contact Life Ratings (Note 8)	10,000,000 cycles (typical) at low level 1,000,000 cycles (typical) at 0.5A/28VDC resistive 100,000 cycles min. at all other loads specified above		
Contact Overload Rating	2 A/28VDC Resistive (100 cycles min.)		
Contact Carry Rating	Contact factory		
Coil Operating Power (Note 6)	412H: 450 mW. typ. @ 25°C	422H: 290 mW typ. @ 25°C	432H: 200 mW typ. @ 25°C
Operate Time (Note 6)	412H: 2.0 msec. max.	422H: 1.5 msec. max.	432H: 4.0 msec. max.
Release Time (Note 6 & 7)	2.0 msec. max.		
Contact Bounce	1.5 msec. max.		
Intercontact Capacitance	0.4 pf. typical		
Insulation Resistance	10,000 megohms min. between mutually isolated terminals		
Dielectric Strength	Sea level: 500 VRMS/60 Hz	70,000 ft.: 125 VRMS/60Hz.	
Minimum Operate Pulse	4.5 msec @ Nominal Rated Voltage (422H only)		

412H SERIES RELAY

DETAILED ELECTRICAL SPECIFICATIONS (-65° to + 200°C unless otherwise noted) (NOTE 2)

GENERIC PART NUMBERS (NOTE 5)		412H-5	412H-6	412H-9	412H-12	412H-18	412H-26
Coil Voltage	Nom.	5.0	6.0	9.0	12.0	18.0	26.5
	Max.	5.8	8.0	12.0	16.0	24.0	32.0
Coil Resistance (Ohms ± 10% @ 25°C)		50	98	220	390	880	1560
Pick-up Voltage (VDC, Max.)		4.7	5.9	9.0	11.9	17.8	24.0
Drop-out Voltage (VDC)	Min.	0.14	0.18	0.35	0.41	0.59	0.89
	Max.	2.4	3.4	5.1	6.8	10.2	13.5

422H SERIES RELAY

DETAILED ELECTRICAL SPECIFICATIONS (-65° to + 200°C unless otherwise noted) (NOTE 2)

GENERIC PART NUMBERS (NOTE 5)		422H-5	422H-6	422H-9	422H-12	422H-18	422H-26
Coil Voltage (VDC)	Nom.	5.0	6.0	9.0	12.0	18.0	26.5
	Max.	5.8	8.0	12.0	16.0	24.0	32.0
Coil Resistance (Ohms ± 10% @ 25°C)		61	120	280	500	1130	2000
Set & Reset Voltage (VDC, Max.)		4.7	5.9	9.0	11.9	17.8	24.0

432H SERIES RELAY

DETAILED ELECTRICAL SPECIFICATIONS (-65° to + 200°C unless otherwise noted) (NOTE 2)

GENERIC PART NUMBERS (NOTE 5)		432H-5	432H-6	432H-9	432H-12	432H-18	432H-26
Coil Voltage	Nom.	5.0	6.0	9.0	12.0	18.0	26.5
	Max.	5.8	8.0	12.0	16.0	24.0	32.0
Coil Resistance (Ohms ± 10% @ 25°C)		100	200	400	850	1600	3300
Pick-up Voltage (VDC, Max.)		4.7	5.9	9.0	11.9	17.8	24.0
Drop-out Voltage (VDC)	Min.	0.14	0.18	0.35	0.41	0.59	0.89
	Max.	2.4	3.4	5.1	6.8	10.2	13.5

PERFORMANCE CURVES (NOTE 1)

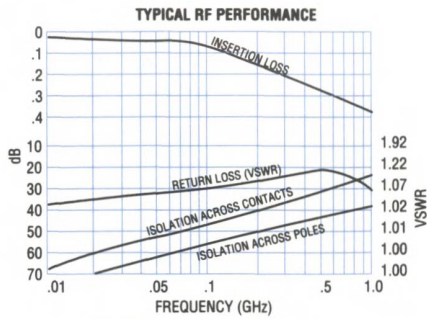

FIGURE 1 (412H) (432H)

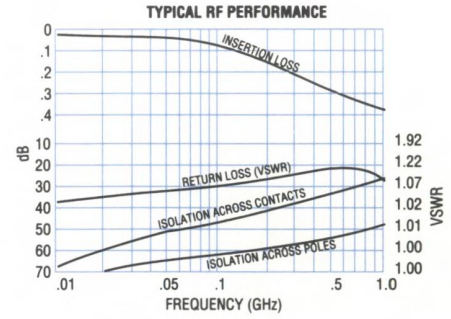

FIGURE 2 (422H)

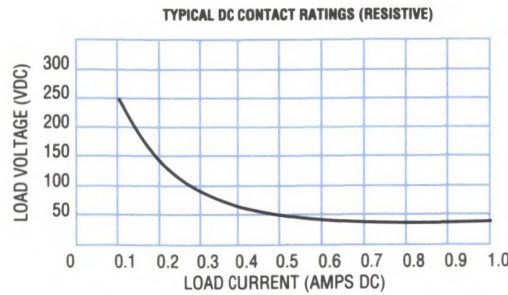
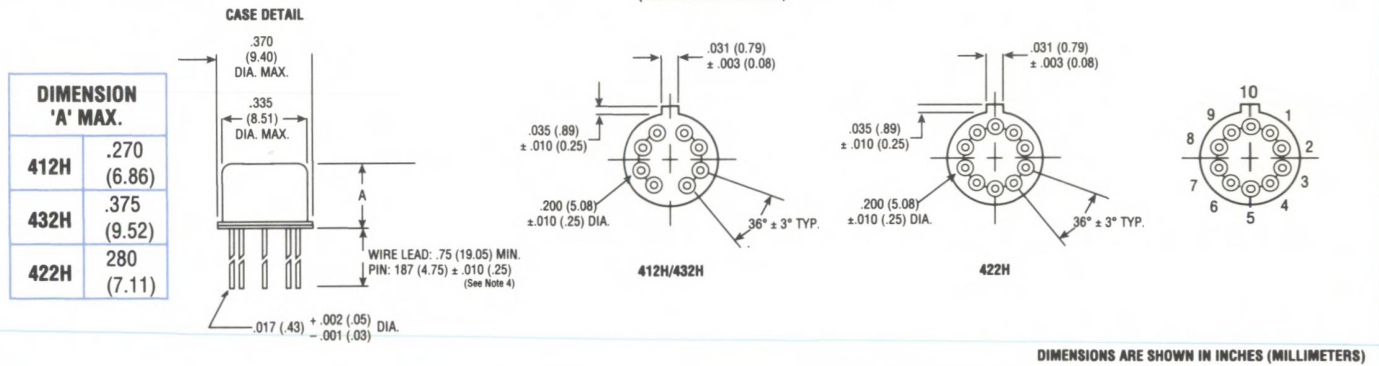
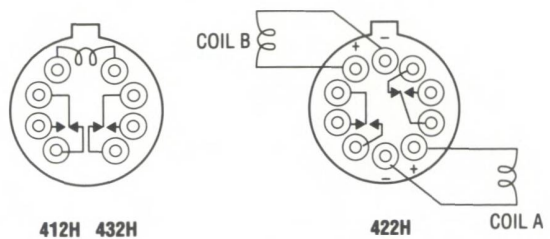

FIGURE 3

OUTLINE DIMENSIONS



SCHEMATIC DIAGRAMS



CONTACTS SHOWN IN POSITION RESULTING WHEN COIL A LAST ENERGIZED.
 SCHEMATICS ARE VIEWED FROM TERMINALS

NOTES:

1. Characteristics shown as "typical" are based on available data and are best estimates. No on-going verification tests are performed.
2. Characteristics are subject to change after life.
3. Relays will exhibit no contact chatter in excess of 10 µsec or transfer in excess of 1 µsec.
4. Unless otherwise specified relays are supplied with 0.75" min. (19.05mm) leads. For .187" (4.74mm) pin versions, add "S" to part number (i.e., 412H-26 becomes 412HS-26).
5. Screened hi-rel versions are available on special order, contact factory.
6. Measured at nominal coil voltage at 25° C
7. Not applicable to 422H Series.
8. Contact load ratings and contact life ratings are based on similarity testing at 125° C. No 200° C testing is performed.

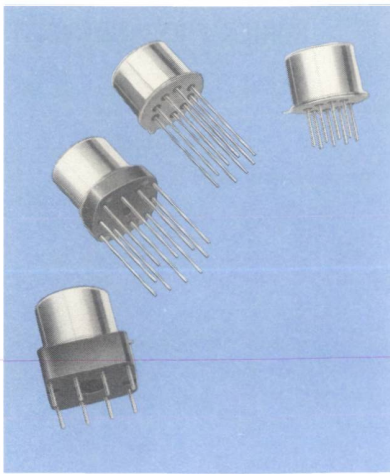

TELEDYNE RELAYS

HIGH SHOCK MILITARY STYLE TO-5 RELAY DPDT

**SERIES
412K
422K**

SERIES DESIGNATION	RELAY TYPE
412K	DPDT high shock relay
422K	DPDT high shock magnetic latching relay

INTERNAL CONSTRUCTION 412K

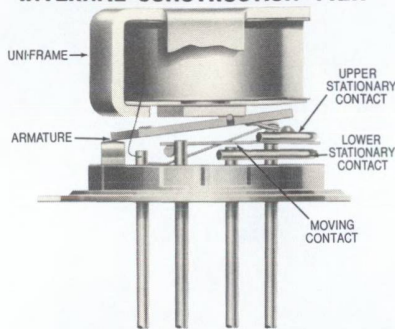

412K ENVIRONMENTAL AND PHYSICAL SPECIFICATIONS

Temperature (Ambient)	-65°C to +125°C
Vibration	30 g's to 3000 Hz (Note 3)
Shock	75 g's 6 msec. (Note 3) 4000 g's 0.5 msec. axial plane 1000 g's 0.5 msec. side planes (Note 6) half-sine
Acceleration	75 g's (Note 3)
Enclosure	All welded, hermetically sealed
Weight	0.09 oz. (2.55 gms.) max.

422K ENVIRONMENTAL AND PHYSICAL SPECIFICATIONS

Temperature (Ambient)	-65°C to +125°C
Vibration	30 g's to 3000 Hz (Note 3)
Shock	100 g's 6 msec. (Note 3) 2000 g's 0.5 msec. (Note 6) half-sine
Acceleration	75 g's (Note 3)
Enclosure	All welded, hermetically sealed
Weight	0.10 oz. (2.84 gms.) max.

DESCRIPTION

The TO-5 relay, originally conceived and developed by Teledyne, has become the industry standard for low level switching from dry circuit to 1 ampere. Designed expressly for high density PC Board mounting, its small size and low coil dissipation make the TO-5 relay the most versatile subminiature relay available.

The High Shock Series of TO-5 Relays are designed to withstand shock levels up to 4000 g's, .5 millisecond duration. Special material selection and construction details provide assurance that critical elements of the relay structure and mechanism will not be permanently displaced or damaged as a result of extremely high g level shocks.

Typical applications are:

- Aircraft avionics and control systems
- Missile control systems
- Spaceflight systems

By virtue of its inherently low intercontact capacitance and contact circuit losses, the TO-5 relay has proven to be an excellent subminiature RF switch for frequency ranges well into the UHF spectrum. A typical RF application for the TO-5 relay is in hand held radio transceivers, wherein the combined features of good RF performance, small size, low coil power dissipation and high reliability make it the preferred relay for T-R switching (see Figure 1 and 2).

PRINCIPLE OF OPERATION 422K

Energizing Coil B produces a magnetic field opposing the holding flux of the permanent magnet in Circuit B. As this net holding force decreases, the attractive force in the air gap of circuit A, which also results from the flux of the permanent magnet, becomes great enough to break the armature free of Core B, and snap it into a closed position against Core A. The armature then remains in this position upon removal of power from Coil B, but will snap back to position B upon energizing Coil A. Since operation depends upon cancellation of a magnetic field, it is necessary to apply the correct polarity to the relay coils as indicated on the relay schematic.

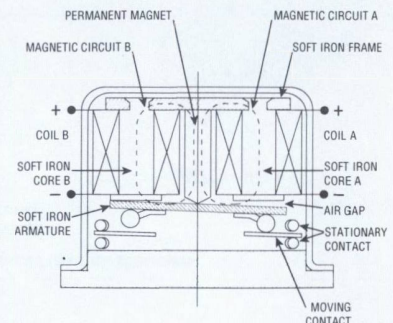

When latching relays are installed in equipment, the latch and reset coils should not be pulsed simultaneously. Coils should not be pulsed with less than the nominal coil voltage and the pulse width should be a minimum of three times the specified operate time of the relay. If these conditions are not followed, it is possible for the relay to be in the magnetically neutral position.

GENERAL ELECTRICAL SPECIFICATIONS (-65°C to +125°C unless otherwise noted) (NOTES 1 AND 2)

Contact Arrangement	2 Form C (DPDT)	
Rated Duty	Continuous	
Contact Resistance	412K: 0.1 ohms max. before life; 0.2 ohms max. after life @ 1A/28VDC, 422K: 0.125 ohms max. before life; 0.225 ohms max. after life @ 1A/28VDC } (measured 1/8" from header)	
Contact Load Rating (DC) (See Fig. 3 for other DC resistive voltage/current ratings)	Resistive: 1 Amp/28VDC Inductive: 200 mA/28VDC (320 mH) Lamp: 100 mA/28VDC Low Level: 10 to 50µA/10 to 50 mV	
Contact Load Ratings (AC)	Resistive: 250 mA/115VAC, 60 and 400 Hz (Case not grounded) 100 mA/115VAC, 60 and 400 Hz, (Case grounded)	
Contact Life Ratings	10,000,000 cycles (typical) at low level 1,000,000 cycles (typical) at 0.5A/28VDC resistive 100,000 cycles min. at all other loads specified above	
Contact Overload Rating	2 A/28VDC Resistive (100 cycles min.)	
Contact Carry Rating	Contact factory	
Coil Operating Power	412K Series: 500 mW. typ. @ 25°C	422K Series: 290 mW typ. @ 25°C
Operate Time (Note 7)	412K Series: 2.0 msec. max.	422K Series: 1.5 msec. max.
Release Time (Note 8)	1.5 msec. max.	
Contact Bounce	1.5 msec. max.	
Intercontact Capacitance	0.4 pf. typical	
Insulation Resistance	10,000 megohms min. between mutually isolated terminals	
Dielectric Strength	Sea level: 500 VRMS/60 Hz 70,000 ft.: 125 VRMS/60Hz.	
Minimum Operate Pulse	4.5 msec @ Nominal-Rated Voltage (422K only)	

412K SERIES RELAY

DETAILED ELECTRICAL SPECIFICATIONS (-65° to +125°C unless otherwise noted) (NOTE 2)

GENERIC PART NUMBERS (NOTE 5)		412K-5	412K-6	412K-9	412K-12	412K-18	412K-26
Coil Voltage	Nom.	5.0	6.0	9.0	12.0	18.0	26.5
	Max.	5.8	8.0	12.0	16.0	24.0	32.0
Coil Resistance (Ohms ± 10% @ 25°C)		50	80	160	300	600	1350
Pick-up Voltage (VDC, Max.)		4.3	5.2	7.6	10.0	14.3	21.0
Drop-out Voltage (VDC)	Min.	0.14	0.18	0.35	0.41	0.59	0.89
	Max.	2.5	3.2	4.9	6.5	10.0	13.0

422K SERIES RELAY

DETAILED ELECTRICAL SPECIFICATIONS (-65° to +125°C unless otherwise noted) (NOTE 2)

GENERIC PART NUMBERS (NOTE 5)		422K-5	422K-6	422K-9	422K-12	422K-18	422K-26
Coil Voltage (VDC)	Nom.	5.0	6.0	9.0	12.0	18.0	26.5
	Max.	5.8	8.0	12.0	16.0	24.0	32.0
Coil Resistance (Ohms ± 10% @ 25°C)		61	120	280	500	1130	2000
Set & Reset Voltage (VDC, Max.)		3.5	4.5	6.8	9.0	13.5	18.0

SERIES 412K/422K

PERFORMANCE CURVES (NOTE 1)

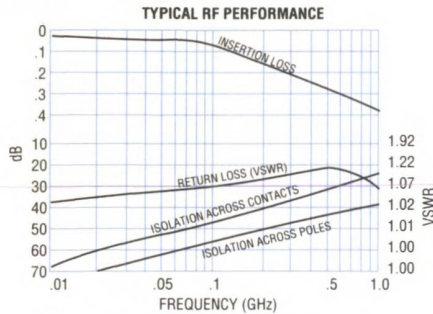

FIGURE 1 (412K)

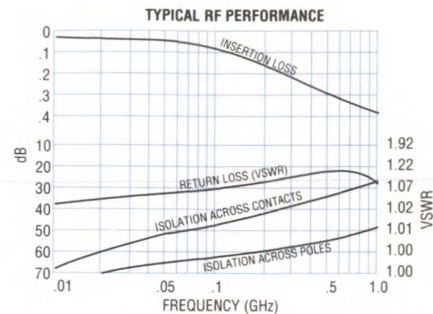

FIGURE 2 (422K)

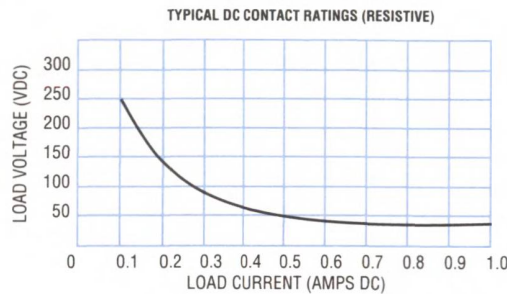
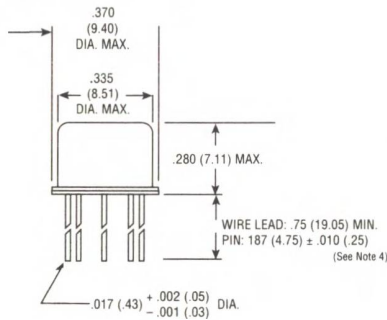
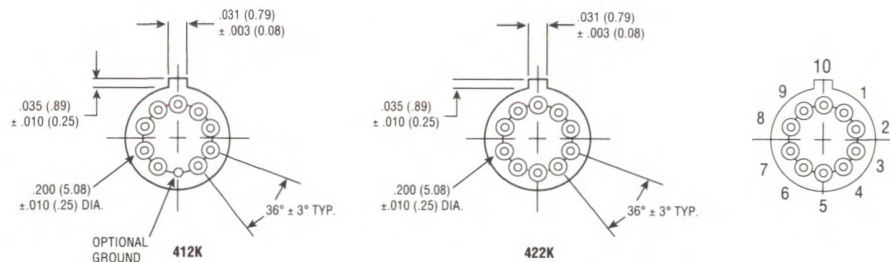

FIGURE 3

OUTLINE DIMENSIONS



TERMINAL LOCATIONS AND PIN NUMBERING (REF. ONLY)



DIMENSIONS ARE SHOWN IN INCHES (MILLIMETERS)

SPREADER PADS

Relays can be supplied with the P/N 192-10 spreader pad installed and cemented in place. To order, add M to the part number (e.g., 422KM-26).

NOTES:

1. Material; Dially phthalate.
2. Add .025 ohm to contact resistance with pad.
3. Spreader Pad conforms to MIL-M-38527.

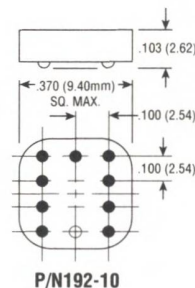

P/N192-10

SCHEMATIC DIAGRAMS

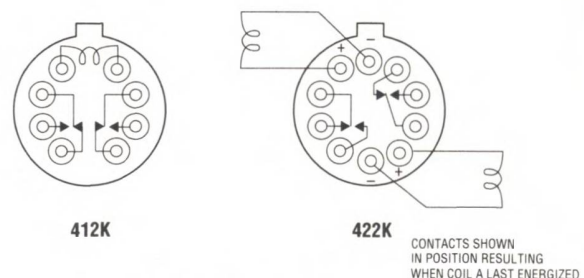

SCHEMATICS ARE VIEWED FROM TERMINALS

NOTES:

1. Characteristics shown as "typical" are based on available data and are best estimates. No on-going verification tests are performed.
2. Characteristics are subject to change after life.
3. Relays will exhibit no contact chatter in excess of 10 µsec or transfer in excess of 1 µsec.
4. Unless otherwise specified relays are supplied with .75" (19.05mm) minimum leads. For .187" (4.74mm) pin versions, add "S" to part number (i.e., 412K-26 becomes 412KS-26).
5. Screened hi-rel versions are available on special order, contact factory.
6. SURVIVAL ONLY—CONTACT CHATTER MAY OCCUR.
7. Measured at nominal rated coil voltage at 25° C.
8. Not applicable to 422K Series.

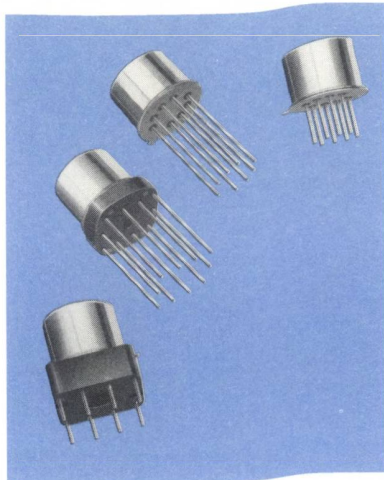

TELEDYNE RELAYS

HIGH VIBRATION MILITARY STYLE TO-5 RELAY DPDT

**SERIES
412V
432V**

SERIES DESIGNATION	RELAY TYPE
412V	DPDT basic high vibration relay
412DV	DPDT high vibration relay with internal diode for coil transient suppression
412DDV	DPDT high vibration relay with internal diodes for coil transient suppression and polarity reversal protection
432V	DPDT basic high vibration, sensitive relay
432DV	DPDT high vibration sensitive relay with internal diode for coil transient suppression

INTERNAL CONSTRUCTION

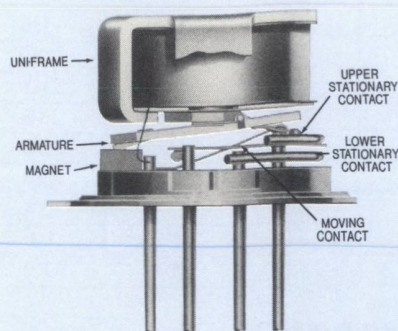

DESCRIPTION

The TO-5 relay, originally conceived and developed by Teledyne, has become the industry standard for low level switching from dry circuit to 1 ampere. Designed expressly for high density PC Board mounting, its small size and low coil power dissipation make the TO-5 relay the most versatile subminiature relay available.

The High Vibration Series of TO-5 Relays are designed to withstand vibration levels of 250 to 380 g's at the frequencies noted when tested on a resonant beam for 10 to 20 seconds in the axis parallel to contact motion (x) axis, or 100 g's 10-2000 Hz for 20 minutes in the "x" axis. A unique magnetic circuit prevents contact opening (chatter) in excess of 10 microseconds under vibration or shock conditions.

Typical applications are:

- Aircraft avionics and control systems
- Missile control systems
- Spaceflight systems

ENVIRONMENTAL AND PHYSICAL SPECIFICATIONS

Temperature (Ambient)	-65°C to +125°C
Vibration (Note 3)	250 g's at 140±5 Hz 350 g's at 170±5 Hz 380 g's at 200±5 Hz
Shock	150 g's for 11 msec. (Note 3) half-sine
Acceleration	75 g's (Note 3)
Enclosure	All welded, hermetically sealed
Weight	412V 0.09 oz. (2.55 gms.) max. 432V 0.15 oz. (4.26 gms.) max.

By virtue of its inherently low intercontact capacitance and contact circuit losses, the TO-5 relay has proven to be an excellent subminiature RF switch for frequency ranges well into the UHF spectrum. A typical RF application for the TO-5 relay is in hand held radio transceivers, wherein the combined features of good RF performance, small size, low coil power dissipation and high reliability make it the preferred relay for Transmit-Receive switching (see Figure 1).

SERIES 412V/432V

GENERAL ELECTRICAL SPECIFICATIONS (-65°C to +125° unless otherwise noted) (NOTES 1 AND 2)

Contact Arrangement	2 Form C (DPDT)	
Rated Duty	Continuous	
Contact Resistance	0.1 ohm max. before life; 0.2 ohm max. after life at 1A/28VDC, (measured 1/8" from header)	
Contact Load Rating (DC) (See Fig. 2 for other DC resistive voltage/current ratings)	Resistive: 1 Amp/28VDC Inductive: 200 mA/28VDC (320 mH) Lamp: 100 mA/28VDC Low Level: 10 to 50µA/10 to 50 mV	
Contact Load Rating (AC)	Resistive: 250 mA/115VAC, 60 and 400 Hz (Case not grounded) 100 mA/115VAC, 60 and 400 Hz (Case grounded)	
Contact Life Ratings	10,000,000 cycles (typical) at low level 1,000,000 cycles (typical) at 0.5A/28VDC resistive 100,000 cycles min. at all other loads specified above	
Contact Overload Rating	2 A/28VDC Resistive (100 cycles min.)	
Contact Carry Rating	Contact factory	
Coil Operating Power	432V Series: 350 mw. typ. at rated voltage @ 25°C	412V Series: 620 mw typ. at rated voltage @ 25°C
Operate Time	432V Series: 4.0 msec. max. at rated coil voltage	412V Series: 2.0 msec. max. at rated coil voltage
Release Time	432V Series: 3.0 msec. max.	432DV Series: 7.5 msec. max.
	412V Series: 2.0 msec max.	412DV, DDV Series: 4.0 msec. max
Contact Bounce	1.5 msec. max.	
Intercontact Capacitance	0.4 pf. typical	
Insulation Resistance	10,000 megohms min. between mutually isolated terminals	
Dielectric Strength	Sea level: 500 VRMS/60 Hz	70,000 ft.: 125 VRMS/60Hz.
Negative Coil Transient (VDC, Max.)	All DV, DDV Versions	1.0 max.
Diode P.I.V. (VDC, Min.)	All DV, DDV Versions	100 min.

412V SERIES DETAILED ELECTRICAL SPECIFICATIONS (-65° to +125°C unless otherwise noted) (NOTE 2)

	GENERIC PART NUMBERS (NOTE 5)	412V-5	412V-6	412V-9	412V-12	412V-18	412V-26	
		412DV-5 412DDV-5	412DV-6 412DDV-6	412DV-9 412DDV-9	412DV-12 412DDV-12	412DV-18 412DDV-18	412DV-26 412DDV-26	
Coil Voltage (VDC)	Nom.	5.0	6.0	9.0	12.0	18.0	26.5	
	Max.	5.8	8.0	12.0	16.0	24.0	32.0	
Coil Resistance (Ohms ± 10% @ 25°C)	412V	50	70	155	235	610	1130	
	412DV (412DDV Note 6)	33	44	125	215	470	1050	
Coil Current (mADC @ 25°C) (Note 7)	412DDV	Min.	92.8	90.4	54.3	37.8	31.3	21.3
		Max.	126.4	122.6	73.4	59.4	42.0	28.3
Pick-up Voltage (VDC, Max.)		4.6	5.5	8.2	11.0	16.5	22.0	
Drop-out Voltage (VDC)	412V	Min.	0.14	0.18	0.35	0.41	0.59	0.89
		Max.	2.3	3.2	4.9	6.5	10.0	13.0
	412DDV	Min.	0.6	0.7	0.8	0.9	1.1	1.4
		Max.	2.8	3.4	5.3	6.5	10.0	13.0

432V SERIES DETAILED ELECTRICAL SPECIFICATIONS (-65° to +125°C unless otherwise noted) (NOTE 2)

	GENERIC PART NUMBERS (NOTE 5)	432V-5	432V-6	432V-9	432V-12	432V-18	432V-26
		432DV-5	432DV-6	432DV-9	432DV-12	432DV-18	432DV-26
Coil Voltage (VDC)	Nom.	5.0	6.0	9.0	12.0	18.0	26.5
	Max.	5.8	8.0	12.0	16.0	24.0	32.0
Coil Resistance (Ohms ± 10% @ 25°C)		80	120	240	480	950	1900
Pick-up Voltage (VDC, Max.)		4.6	5.5	8.2	11.0	16.5	22.0
Drop-out Voltage (VDC)	Min.	0.14	0.18	0.35	0.41	0.59	0.89
	Max.	2.5	3.2	4.9	6.5	10.0	13.0

PERFORMANCE CURVES (NOTE 1)

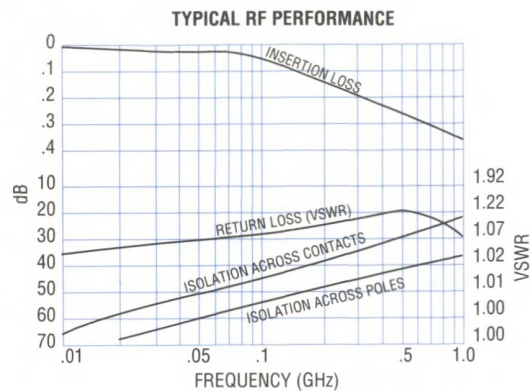

FIGURE 1

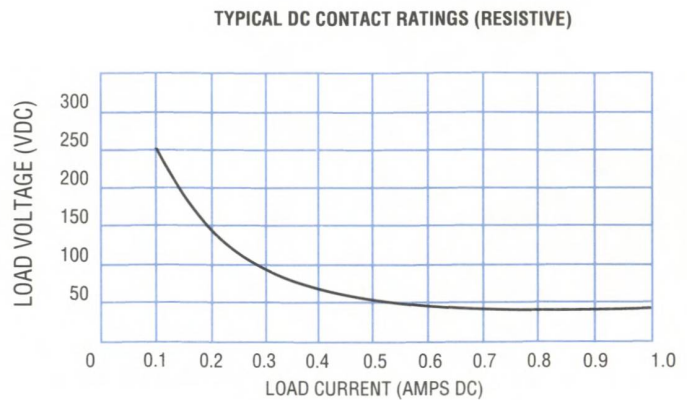
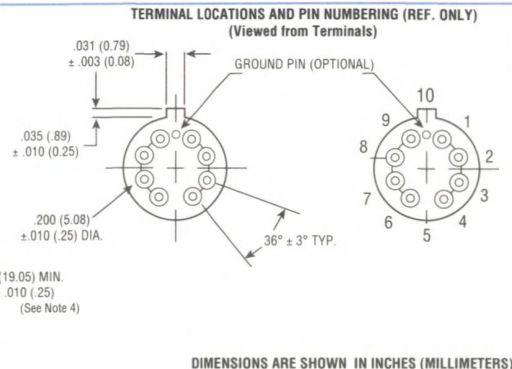
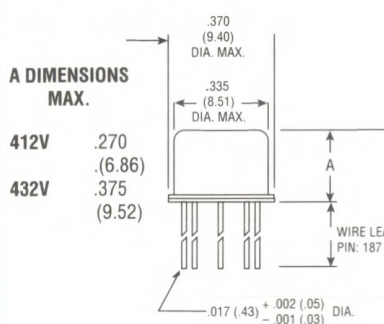
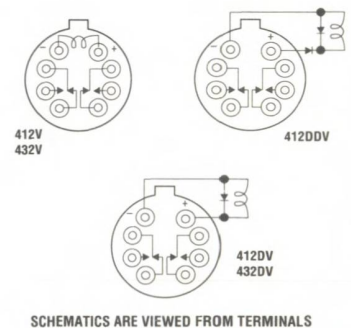

FIGURE 2

OUTLINE DIMENSIONS



SCHEMATIC DIAGRAMS



SPREADER PADS

Relays can be supplied with spreader pads installed and cemented in place. P/N 192-10 can be used with all High Vibration relays. Relays supplied with 192-59 pad installed have leads trimmed to .130 in. (3.3mm) ± .010 (.25mm) below pad. To order, add M for the 192-10 pad or M2 for the 192-59 pad to the part number (e.g., 412VM2-26).

NOTES:

- Material: Diallyl phthalate.
- Add .025 ohm to contact resistance with 192-10 pad; .05 ohm with 192-59 pad.

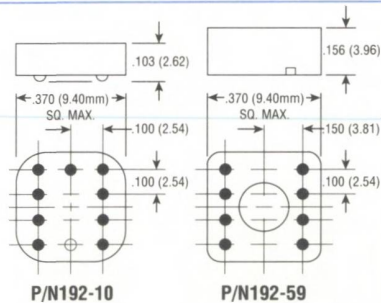

- Spreader pads conform to MIL-M-38527.
- Leads exit from holes indicated.
- Tolerance: .XXX ± .005 (0.13).

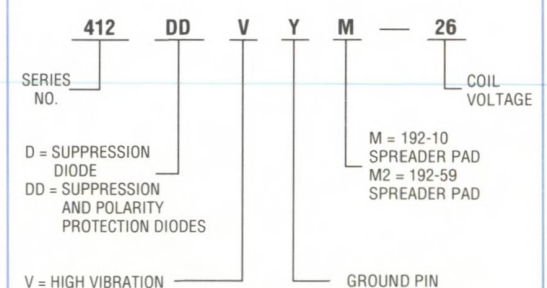

NOTES:

- Characteristics shown as "typical" are based on available data and are best estimates. No on-going verification tests are performed.
- Characteristics are subject to change after life.
- Relays will exhibit no contact chatter in excess of 10 μsec or transfer in excess of 1 μsec. For other vibration levels, contact factory.
- Unless otherwise specified relays are supplied with .75" (19.05mm) minimum leads. For .187" (4.75mm) pin versions, add "S" to part number (i.e., 412V-26 becomes 412VS-26).
- Screened hi-rel versions are available on special order. Contact factory.
- For reference only. Coil resistance not directly measurable at relay terminals due to internal series semiconductor.
- Measured at nominal voltage for 5 sec. maximum.

TELEDYNE RELAYS

MILITARY STYLE CENTIGRID[®] MAGNETIC LATCHING R.F. RELAYS

DPDT

SERIES
RF120

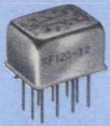

DESCRIPTION

The RF120 Series relay is an ultraminiature, hermetically sealed, magnetic-latching relay featuring extremely low intercontact capacitance for exceptional R.F. performance over the full UHF spectrum. Its low profile height and .100" grid spaced terminals (precluding the need for spreader pads) make it ideal for applications where extreme packaging density and/or close PC board spacing are required.

The basic design and internal structure are similar to the T0-5 421 Series relay. The relay is capable of meeting the requirements of MIL-R-39016. In addition, the RF120 design has been optimized for use in RF attenuators, RF switch matrices, and other applications requiring high isolation, low insertion loss, and low VSWR.

Unique construction features and manufacturing techniques provide overall high reliability and excellent resistance to environmental extremes:

- All welded construction.
- Unique uni-frame design providing high magnetic efficiency and mechanical rigidity.
- High force/mass ratios to withstand shock and vibration.
- Advanced cleaning and sealing techniques provide maximum assurance of internal cleanliness.
- Gold plated precious metal alloy contacts ensure reliable d.c. switching from dry-circuit to 1/2 amp, as well as low, stable insertion loss.

The RF120 relay is ideally suited for applications where power dissipation must be minimized. The relays can be operated with a short-duration pulse. After the contacts have transferred, no holding power is required.

The magnetic-latching feature of the RF120 Series provides a "memory" capability, since the relays will not reset upon removal of coil power.

PRINCIPLE OF OPERATION

Energizing Coil B produces a magnetic field opposing the holding flux of the permanent magnet in Circuit B. As this net holding force decreases, the attractive force in the air gap of Circuit A, which also results from the flux of the permanent magnet, becomes great enough to break the armature free of Core B, and snap it into a closed position against Core A. The armature then remains in this position upon removal of power from Coil B, but will snap back to position B upon energizing Coil A. Since operation depends upon cancellation of a magnetic field, it is necessary to apply the correct polarity to the relay coils as indicated on the relay schematic.

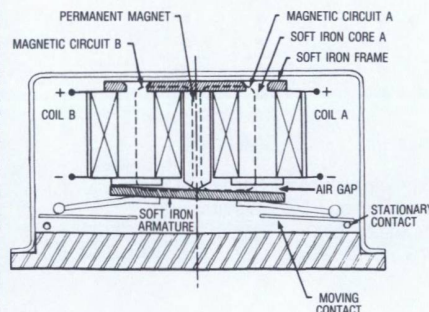

When latching relays are installed in equipment, the latch and reset coils should not be pulsed simultaneously. Coils should not be pulsed with less than the nominal coil voltage and the pulse width should be a minimum of three times the specified operate time of the relay. If these conditions are not followed, it is possible for the relay to be in the magnetically neutral position.

ENVIRONMENTAL AND PHYSICAL SPECIFICATIONS

Temperature (Ambient)	-65°C to +125°C
Vibration	30 g's to 3000 Hz (Note 3)
Shock	100 g's for 6 msec. (Note 3) half-sine
Acceleration	75 g's (Note 3)
Enclosure	All welded, hermetically sealed
Weight	0.10 oz. (2.84 gms.) max.

GENERAL ELECTRICAL SPECIFICATIONS (-65°C to +125°C unless otherwise noted) (NOTES 1 AND 2)

Contact Arrangement	2 Form C (DPDT)	
Rated Duty	Continuous	
Contact Resistance	0.125 ohm max. before life; 0.225 ohm max. after life at 0.5A/28VDC, (measured 1/8" from header)	
Contact Load Rating (DC)	Resistive: 0.5 Amp/28VDC Inductive: 100 mA/28VDC (320 mH) Lamp: 50 mA/28VDC Low Level: 10 to 50 μA/10 to 50 mV	
Contact Life Ratings	10,000,000 cycles (typical) at low level 100,000 cycles min. at all other loads specified above	
Contact Overload Rating	1 A/28VDC Resistive (100 cycles min.)	
Contact Carry Rating	Contact factory	
Coil Operating Power	290 milliwatts typical at nominal rated voltage @ 25°C	
Operate Time	1.5 msec. max. at nominal rated coil voltage	
Contact Bounce	2.0 msec. max.	
Minimum Operate Pulse	4.5 msec. at nominal voltage	
Intercontact Capacitance	0.02 pF. typical	
Insulation Resistance	10,000 megohms min. between mutually isolated terminals	
Dielectric Strength	Sea level: 500 VRMS/60 Hz	70,000 ft. 125 VRMS/60 Hz

DETAILED ELECTRICAL SPECIFICATIONS (-65°C to +125°C unless otherwise noted) (NOTE 2)

GENERIC PART NUMBERS (NOTE 5)	RF120-5	RF120-6	RF120-9	RF120-12	RF120-18	RF120-26
	Coil Voltage (VDC)	Nom. 5.0	6.0	9.0	12.0	18.0
	Max. 6.0	8.0	12.0	16.0	24.0	32.0
Coil Resistance (Ohms ± 10% @ 25°C)	61	120	280	500	1130	2000
Set & Reset Voltage (VDC, Max.)	3.5	4.5	6.8	9.0	13.5	18.0

TYPICAL R.F. PERFORMANCE (NOTE 1)

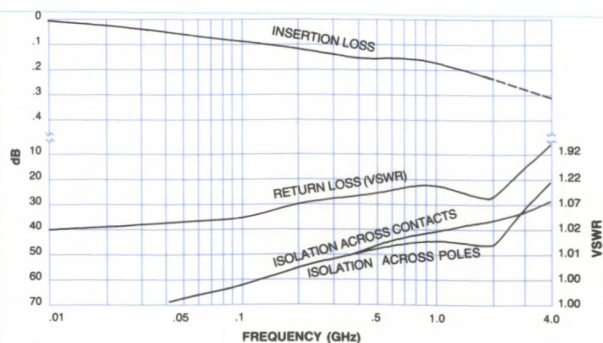

OUTLINE DIMENSIONS

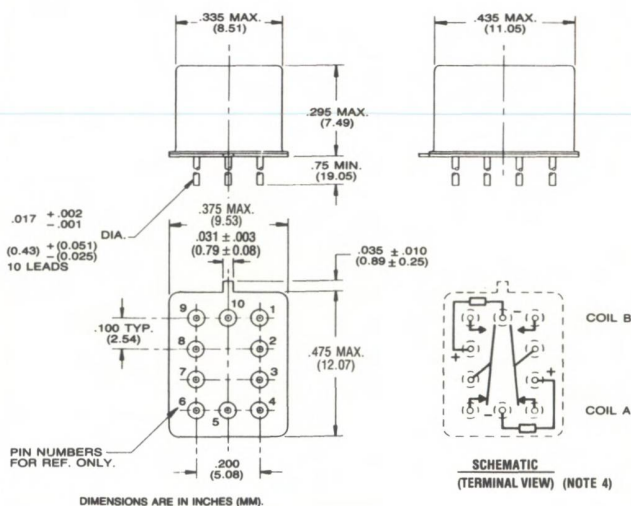

NOTES

1. Characteristics shown as "typical" are based on available data and are best estimates. No on-going verification tests are performed.
2. Characteristics are subject to change after life.
3. Relays will exhibit no contact chatter in excess of 10 μsec or transfer in excess of 1 μsec.
4. Contacts shown in position resulting when coil A last energized.
5. Screened hi rel versions available on special order. Contact factory.

TELEDYNE RELAYS

CENTIGRID® SURFACE MOUNT MILITARY STYLE RELAY DPDT

SERIES S114

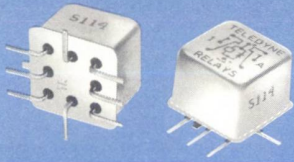

SERIES DESIGNATION	RELAY TYPE
S114	DPDT basic relay
S114D	DPDT relay with internal diode for coil transient suppression
S114DD	DPDT relay with internal diodes for coil transient suppression and polarity reversal protection

INTERNAL CONSTRUCTION

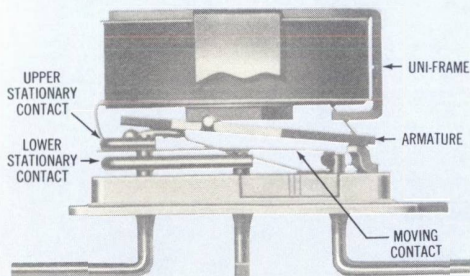

DESCRIPTION

The S114 Series Surface Mount Centigrad® Relay is an ultraminiature, hermetically sealed, armature relay. The low profile height (.365") and .100" lead spacing make it ideal for applications where extreme packaging density and/or close PC board spacing are required. The specially formed leads are pre-tinned to make the relays ideal for all types of surface mount solder reflow processes.

The basic design and internal construction are identical to the 114 Series Centigrad® relays, and are capable of meeting the requirements of MIL-R-39016. The following unique construction features and manufacturing techniques provide overall high reliability and excellent resistance to environmental extremes:

- All welded construction.
- Unique uni-frame design provides high magnetic efficiency and mechanical rigidity.
- High force/mass ratios for resistance to shock and vibration.
- Advanced cleaning and sealing techniques provide maximum assurance of internal cleanliness.
- Precious metal alloy contact material with gold plating assures excellent high current and dry circuit switching capabilities.

The S114D and S114DD Series utilize internal discrete silicon diodes, with characteristics similar to 1N5315.

By virtue of its inherently low intercontact capacitance and contact circuit losses, the S114 relay has proven to be an excellent subminiature RF switch for frequency ranges well into the UHF spectrum. A typical RF application for the S114 relay is in hand held radio transceivers, wherein the combined features of good RF performance, small size, low coil power dissipation and high reliability make it the preferred relay for transmit-receive switching (see Figures 1 and 2).

ENVIRONMENTAL AND PHYSICAL SPECIFICATIONS

Temperature (Ambient)	-65°C to +125°C
Vibration	30 g's to 3000 Hz (Note 3)
Shock	75 g's for 6 msec. (Note 3) half-sine
Acceleration	75 g's (Note 3)
Enclosure	All welded, hermetically sealed
Weight	0.07 oz. (1.9 gms.) max.
Reflow Temperature	260°C max. temp. 5 min. max. above 180°C

GENERAL ELECTRICAL SPECIFICATIONS (-65°C to +125°C unless otherwise noted) (NOTES 1 AND 2)

Contact Arrangement	2 Form C (DPDT)	
Rated Duty	Continuous	
Contact Resistance (Note 4)	0.1 ohm max. before life; 0.2 ohm max. after life at 1A/28VDC, (measured 1/8" from header along lead)	
Contact Load Ratings (DC) (See Figure 3 for other DC resistive voltage/current ratings)	Resistive: 1 Amp/28VDC Inductive: 200 mA/28VDC (320 mH) Lamp: 100 mA/28VDC Low Level: 10 to 50 μ A/10 to 50 mVDC	
Contact Load Ratings (AC)	Resistive: 250 mA/115 VAC, 60 and 400 Hz (Case undergrounded) 100 mA/115VAC, 60 and 400 Hz (Case grounded)	
Contact Life Ratings	10,000,000 cycles (typical) at low level 1,000,000 cycles (typical) at 0.5A/28VDC resistive 100,000 cycles min. at all other loads specified above	
Contact Overload Rating	2 A/28VDC Resistive (100 cycles min.)	
Contact Carry Rating	Contact factory	
Coil Operating Power	450 milliwatts typical at nominal rated voltage at 25°C	
Operate Time	2.0 msec. max. at nominal rated coil voltage at 25°C	
Release Time	S114 Series: 1.5 msec. max.	S114D, S114DD Series: 4.0 msec. max.
Contact Bounce	1.5 msec. max.	
Intercontact Capacitance	0.4 pf. typical	
Insulation Resistance	10,000 megohms min. between mutually isolated terminals	
Dielectric Strength	Sea level: 500 VRMS/60 Hz	70,000 ft.: 125 VRMS/60 Hz
Diode P.I.V. S114D, S114DD	100 VDC, min.	
Negative Coil Transient S114D, S114DD	1.0 VDC, max.	

DETAILED ELECTRICAL SPECIFICATIONS (-65°C to +125°C unless otherwise noted) (NOTE 2)

	GENERIC PART NUMBERS	S114-5	S114-6	S114-9	S114-12	S114-18	S114-26	
		S114D-5 S114DD-5	S114D-6 S114DD-6	S114D-9 S114DD-9	S114D-12 S114DD-12	S114D-18 S114DD-18	S114D-26 S114DD-26	
Coil Voltage (VDC)	Nom.	5.0	6.0	9.0	12.0	18.0	26.5	
	Max.	5.8	8.0	12.0	16.0	24.0	32.0	
Coil Resistance (Ohms \pm 10% @ 25°C)	S114, S114D	50	98	220	390	880	1560	
	S114DD (Note 4)	39	78	220	390	880	1560	
Coil Current (mA DC @ 25°C) (S114DD Series only)	(Note 5)	Min.	93.2	57.8	33.0	25.6	17.5	14.8
		Max.	128.2	74.8	42.9	32.8	22.1	18.5
Pick-up Voltage (VDC, Max.)	S114, S114D	3.5	4.5	6.8	9.0	13.5	18.0	
	S114DD	4.0	5.0	7.8	10.0	14.5	19.0	
Dropout Voltage (VDC)	S114	Min.	0.14	0.18	0.35	0.41	0.59	0.89
		Max.	2.3	3.2	4.9	6.5	10.0	13.0
	S114DD	Min.	0.6	0.7	0.8	0.9	1.1	1.4
		Max.	2.8	3.4	5.3	6.5	10.0	13.0

PERFORMANCE CURVES (NOTE 1)

TYPICAL RF PERFORMANCE (NOTE 10)

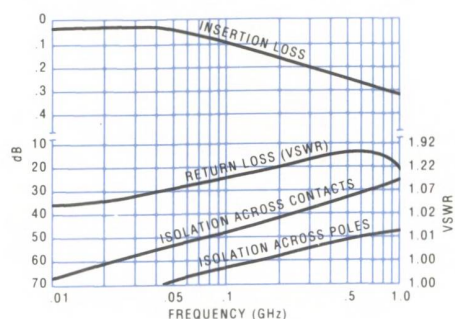

FIGURE 1

TYPICAL DC CONTACT RATINGS (RESISTIVE)

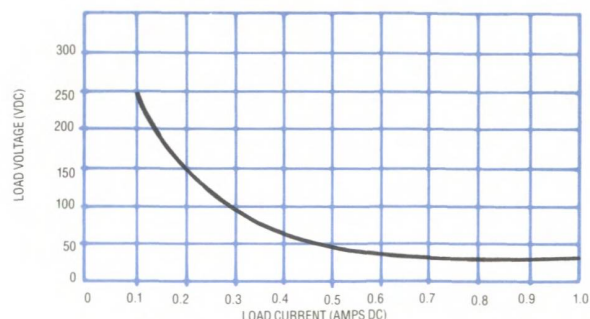
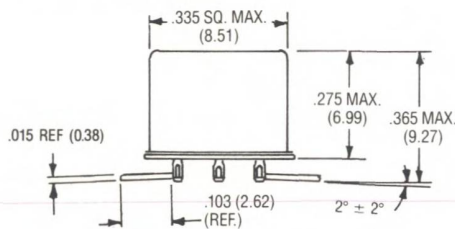

FIGURE 2

SERIES S114

OUTLINE DIMENSIONS



RECOMMENDED PAD LAYOUT (NOTES 7 AND 8)

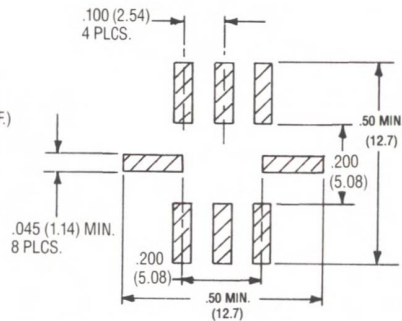
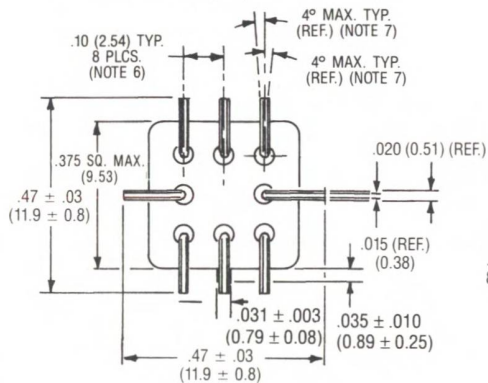

ALL DIMENSIONS ARE IN INCHES (MILLIMETERS).

TELEDYNE PART NUMBERING SYSTEM FOR SURFACE MOUNT RELAYS

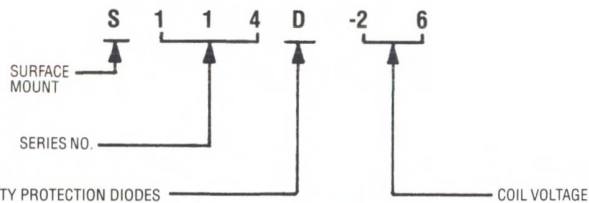

TERMINAL LOCATIONS AND SCHEMATIC DIAGRAMS

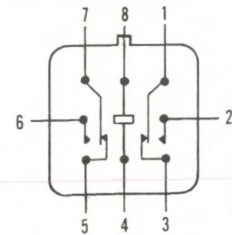

S114

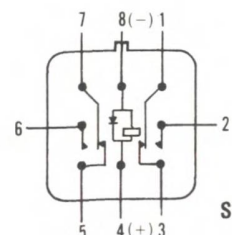

S114D

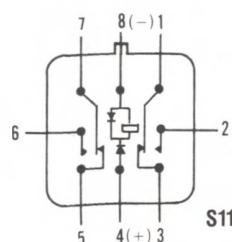

S114DD

SCHEMATICS ARE VIEWED FROM TERMINALS

NOTES

1. Characteristics shown as "typical" are based on available data and are best estimates. No on-going verification tests are performed.
2. Characteristics are subject to change after life.
3. Relays will exhibit no contact chatter in excess of 10 μ sec or transfer in excess of 1 μ sec.
4. For reference only. Coil resistance not directly measurable at relay terminals due to internal series diode.
5. Measured at nominal voltage for 5 sec. max.
6. Position of leads as they emerge from relay base.
7. Leads will fit noted pad layout with no overhang.
8. Lead ends are coplanar within .008" wide tolerance zone.
9. Terminals coated with SN60 or SN63 solder per QQ-S-571. Kovar exposed at sheared end of leads.
10. RF performance curves based on testing of 114 series relays.

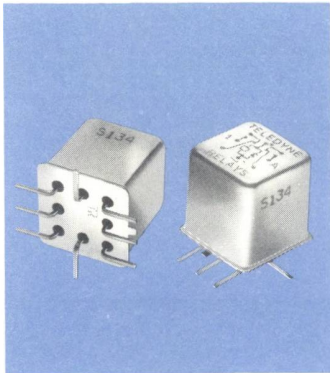

TELEDYNE RELAYS

CENTIGRID® SURFACE MOUNT MILITARY STYLE RELAY SENSITIVE DPDT

SERIES
S134

SERIES DESIGNATION	RELAY TYPE
S134	DPDT basic relay
S134D	DPDT relay with internal diode for coil transient suppression
S134DD	DPDT relay with internal diodes for coil transient suppression and polarity reversal protection

INTERNAL CONSTRUCTION

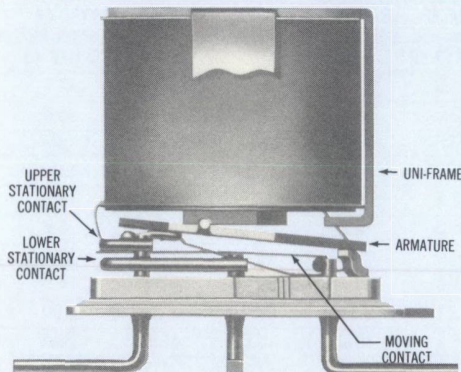

DESCRIPTION

The S134 Series Sensitive Surface Mount Centigrid® Relay is an ultraminiature, hermetically sealed, armature relay. The low profile height (.465") and .100" lead spacing make it ideal for applications where extreme packaging density and/or close PC board spacing are required. The specially formed leads are pre-tinned to make the relays ideal for all types of surface mount solder reflow processes.

The basic design and internal construction are identical to the 134 Series Centigrid® relays, and are capable of meeting the requirements of MIL-R-39016. The following unique construction features and manufacturing techniques provide overall high reliability and excellent resistance to environmental extremes:

- All welded construction.
- Unique uni-frame design provides high magnetic efficiency and mechanical rigidity.
- High force/mass ratios for resistance to shock and vibration.
- Advanced cleaning and sealing techniques provide maximum assurance of internal cleanliness.
- Precious metal alloy contact material with gold plating assures excellent high current and dry circuit switching capabilities.

The S134D and S134DD Series utilize internal discrete silicon diodes, with characteristics similar to 1N5315.

The sensitive Surface Mount Centigrid® relay features exceptionally high coil resistance thus providing for extremely low operating power (200 mw typical). The advantages of reduced heat dissipation and power supply demands are obvious.

By virtue of its inherently low intercontact capacitance and contact circuit losses, the S134 relay has proven to be an excellent subminiature RF switch for frequency ranges well into the UHF spectrum. A typical RF application is in hand held radio transceivers, wherein the combined features of good RF performance, small size, low coil power dissipation, and high reliability make it the preferred relay for transmit-receive switching (see Figures 1 and 2).

ENVIRONMENTAL AND PHYSICAL SPECIFICATIONS

Temperature (Ambient)	-65°C to +125°C
Vibration	30 g's to 3000 Hz (Note 3)
Shock	75 g's for 6 msec. (Note 3) half-sine
Acceleration	75 g's (Note 3)
Enclosure	All welded, hermetically sealed
Weight	0.11 oz. (3.1 gms.) max.
Reflow Temperature	260°C max. temp. 5 min. max. above 180°C

SERIES S134

GENERAL ELECTRICAL SPECIFICATIONS (−65°C to +125°C unless otherwise noted) (NOTES 1 AND 2)

Contact Arrangement	2 Form C (DPDT)	
Rated Duty	Continuous	
Contact Resistance	0.1 ohm max. before life; 0.2 ohm max. after life at 1A/28VDC, (measured 1/8" from header along lead)	
Contact Load Ratings (DC) (See Figure 2 for other DC resistive voltage/current ratings)	Resistive: 1 Amp/28VDC Inductive: 200 mA/28VDC (320 mH) Lamp: 100 mA/28VDC Low Level: 10 to 50 μ A/10 to 50 mVDC	
Contact Load Ratings (AC)	Resistive: 250 mA/115 VAC, 60 and 400 Hz (Case underground) 100 mA/115VAC, 60 and 400 Hz (Case grounded)	
Contact Life Ratings	10,000,000 cycles (typical) at low level 1,000,000 cycles (typical) at 0.5A/28VDC resistive 100,000 cycles min. at all other loads specified above	
Contact Overload Rating	2 A/28VDC Resistive (100 cycles min.)	
Contact Carry Rating	Contact factory	
Coil Operating Power	200 milliwatts typical at nominal rated voltage at 25°C	
Operate Time	4.0 msec. max. at nominal rated voltage at 25°C	
Release Time	S134 Series: 2.0 msec. max.	S134D, S134DD Series: 7.5 msec. max.
Contact Bounce	1.5 msec. max.	
Intercontact Capacitance	0.4 pf. typical	
Insulation Resistance	10,000 megohms min. between mutually isolated terminals	
Dielectric Strength	Sea level: 500 VRMS/60 Hz	70,000 ft.: 125 VRMS/60 Hz
Diode P.I.V. S134D, S134DD	100 VDC, min.	
Negative Coil Transient S134D, S134DD	1.0 VDC, max.	

DETAILED ELECTRICAL SPECIFICATIONS (−65°C to +125°C unless otherwise noted) (NOTE 2)

	GENERIC PART NUMBERS	S134-5	S134-6	S134-9	S134-12	S134-18	S134-26	S134-36	S134-48	
		S134D-5 S134DD-5	S134D-6 S134DD-6	S134D-9 S134DD-9	S134D-12 S134DD-12	S134D-18 S134DD-18	S134D-26 S134DD-26	S134D-36 S134DD-36	S134D-48 S134DD-48	
Coil Voltage (VDC)	Nom.	5.0	6.0	9.0	12.0	18.0	26.5	36.0	48.0	
	Max.	7.5	10.0	15.0	20.0	30.0	40.0	57.0	75.0	
Coil Resistance (Ohms \pm 10% @ 25°C)	S134, S134D	100	200	400	800	1600	3200	6500	11000	
	S134DD (Note 4)	64	125	400	800	1600	3200	6500	11000	
Coil Current (mADC @ 25°C) (S134DD Series only)	(Note 5)	Min.	56.8	36.3	18.1	12.5	9.6	7.2	4.9	3.9
		Max.	78.1	48.9	23.6	16.0	12.2	9.0	6.1	4.8
Pick-up Voltage (VDC, Max.)	S134, S134D	3.5	4.5	6.8	9.0	13.5	18.0	27.0	36.0	
	S134DD	3.7	4.8	8.0	11.0	14.5	19.0	27.2	34.8	
Drop Out Voltage (VDC)	S134	Min.	0.12	0.18	0.35	0.41	0.59	0.89	1.25	1.60
		Max.	2.5	3.2	4.9	6.5	10.0	13.0	19.0	26.0
	S134DD	Min.	0.7	0.8	0.9	1.0	1.1	1.3	1.7	2.0
		Max.	2.6	3.0	4.5	5.8	9.0	13.0	19.0	26.0

PERFORMANCE CURVES (NOTE 1)

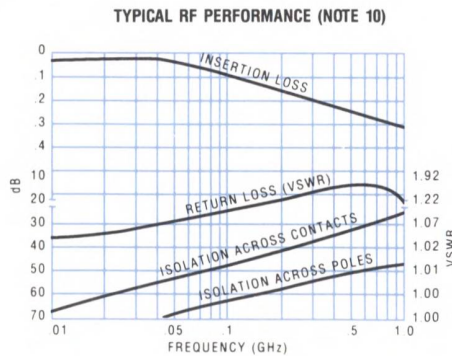

FIGURE 1

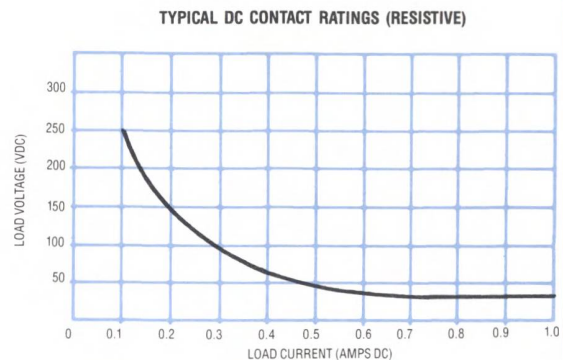
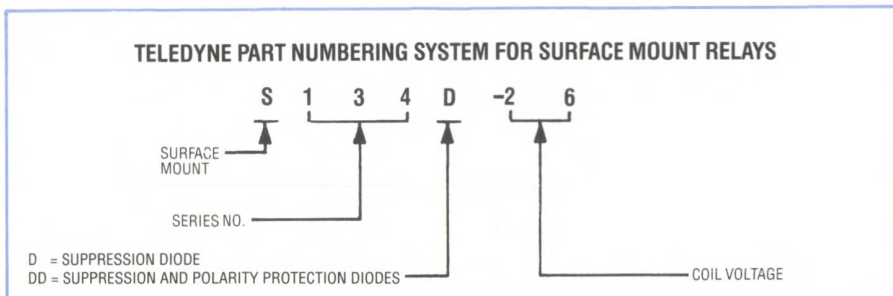
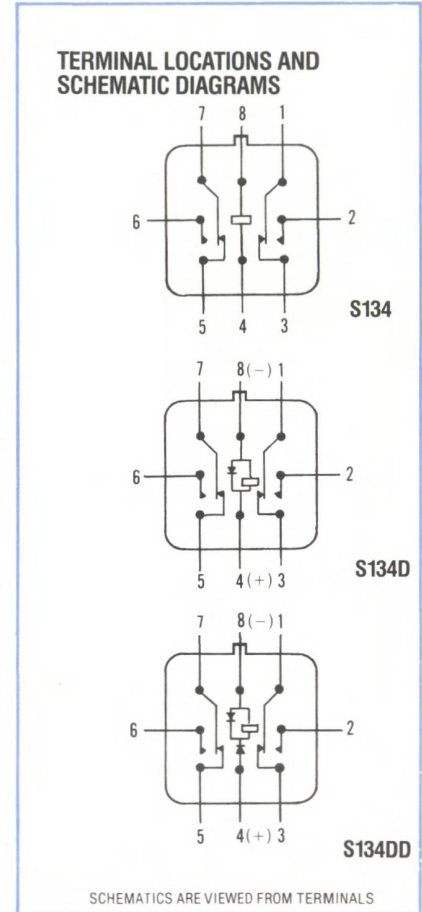
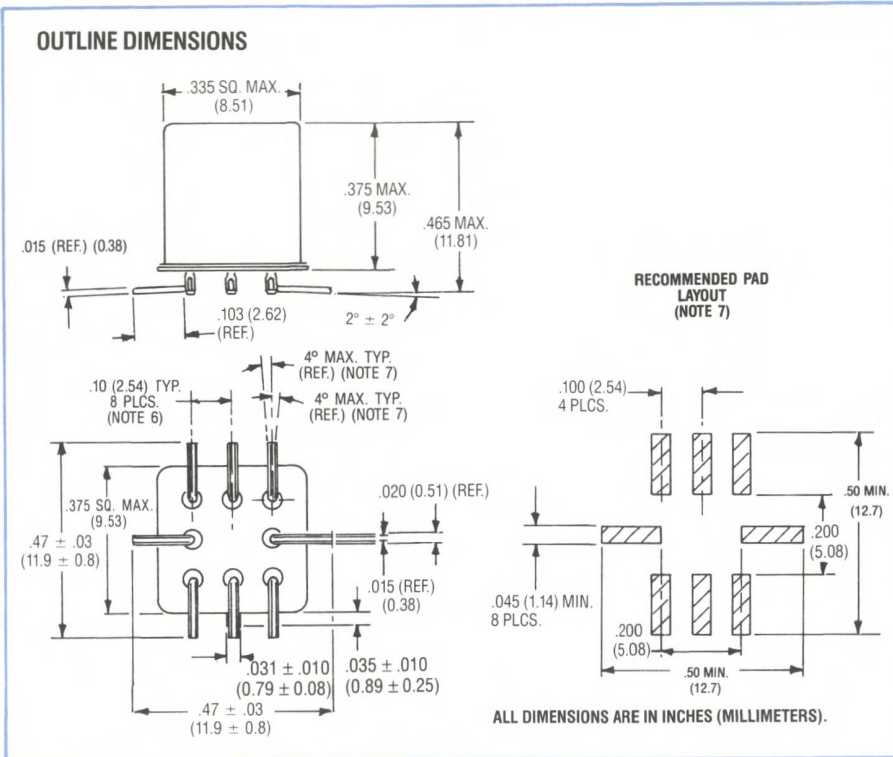
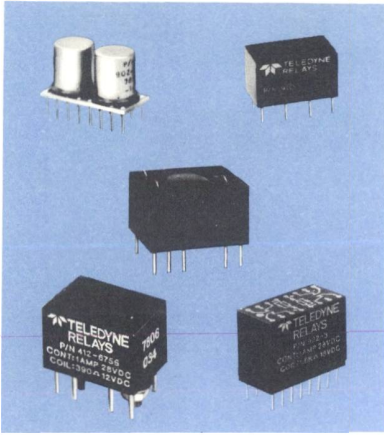

FIGURE 2



NOTES

1. Characteristics shown as "typical" are based on available data and are best estimates. No on-going verification tests are performed.
2. Characteristics are subject to change after life.
3. Relays will exhibit no contact chatter in excess of 10 μ sec or transfer in excess of 1 μ sec.
4. For reference only. Coil resistance not directly measurable at relay terminals due to internal series diode.
5. Measured at nominal voltage for 5 sec. max.
6. Position of leads as they emerge from relay base.
7. Leads will fit noted pad layout with no overhang.
8. Lead ends are coplanar within .008" wide tolerance zone.
9. Terminals coated with SN60 or SN63 solder per QQ-S-571. Kovar exposed at sheared end of leads.
10. RF performance curves based on 134 series relays.



TELEDYNE RELAYS

SPECIAL PACKAGES

**SERIES
902
910**

GENERAL DESCRIPTION

The TO-5 relay, originally conceived and developed by Teledyne, has become the industry standard for low level switching from dry circuit to 1 ampere. Its small size, low coil power dissipation and unique processing make the Teledyne TO-5 relay a versatile and reliable performer. Because of its small size and high reliability, the TO-5 has often been called upon to replace other

relays or to be incorporated into custom designs. To achieve this, the TO-5 has been repackaged in some of the more familiar package configurations. Below are examples of frequently requested packages. The 902 Series contains two TO-5 relays where the 910 Series uses a single relay. Other special designs can be made at the customer's request.

902-3

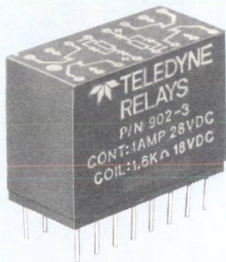

One of the most frequently asked for configurations is the DIP. In this design, two sensitive 432 relays are packaged together in a diallyl phthalate cup and then potted. The device retains all of the specifications of the TO-5 relay itself over a temperature range of -55°C to 125°C. Many variations of this relay; i.e., relays with different coil voltage, series diodes, and transistor drivers are also available.

OUTLINE DIMENSIONS

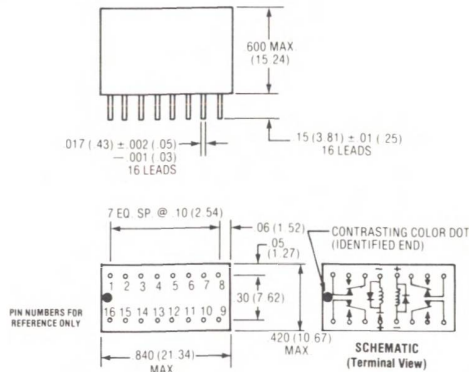

DIMENSIONS ARE SHOWN IN INCHES (MM)
TOLERANCES: .XX = ±.01" (0.25); .XXX = ±.005" (0.13)

902-18

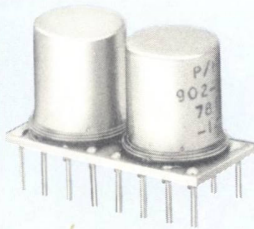

This relay is designed to be a direct plug-in replacement for the AMP53451-1. Two 732 relays are mounted side by side on a PCB providing either 4 PDT or dual 2 PDT operation depending on how the relay coils are connected.

OUTLINE DIMENSIONS

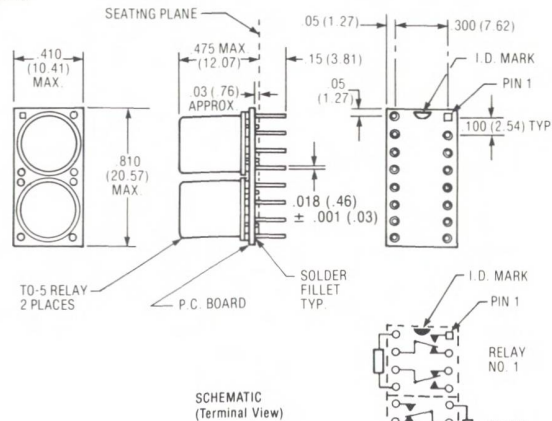

DIMENSIONS ARE SHOWN IN INCHES (MM)
TOLERANCES: .XX = ±.01" (0.25); .XXX = ±.005" (0.13)

SERIES 910

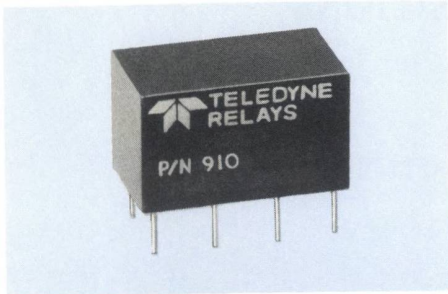

A single TO-5 relay is mounted in a diallyl phthalate cup and potted to provide a replacement for the popular 1/2 crystal can relay. The length of the package has been reduced to 0.710 in. (0.1 in. shorter than the 1/2 crystal can). The 910 relay has been used where high reliability is essential at contact currents of 1 amp or less.

OUTLINE DIMENSIONS

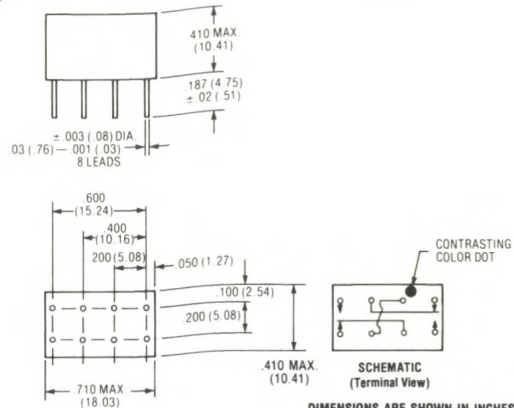

DIMENSIONS ARE SHOWN IN INCHES (MILLIMETERS)
TOLERANCES: .XX = ±.01" (0.25); .XXX = ±.005" (0.13)

412-6756

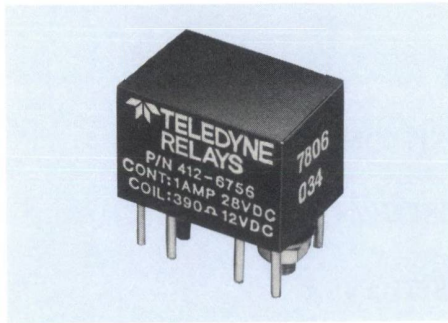

Another example of a special package employs the 412 relay potted in a diallyl phthalate cup with heavy duty terminals and mounting studs.

OUTLINE DIMENSIONS

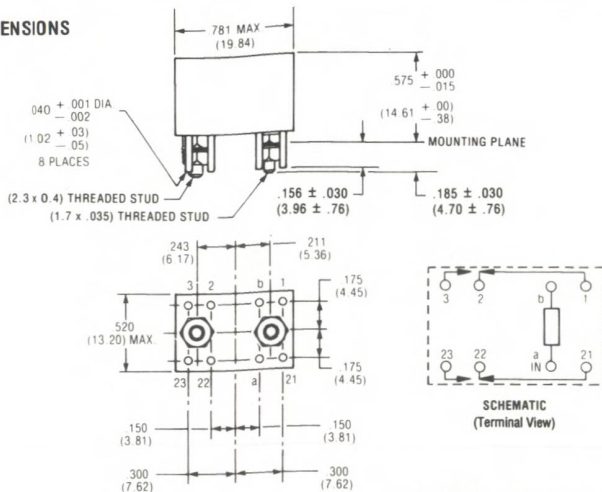

DIMENSIONS ARE SHOWN IN INCHES (MILLIMETERS)
TOLERANCES: .XX = ±.01" (0.25); .XXX = ±.005" (0.13)

422D-8193

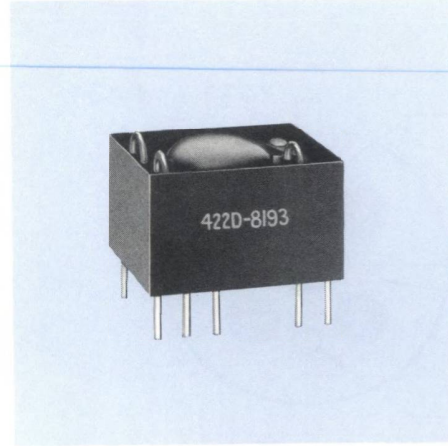

This specialized package, designed for a unique application, uses a 422D latch relay with the DPDT contacts wired in series to achieve very low contact resistance and is potted into a diallyl phthalate cup. Terminals are brought out on a DIP pattern and test point terminals are brought out on the top of the package.

OUTLINE DIMENSIONS

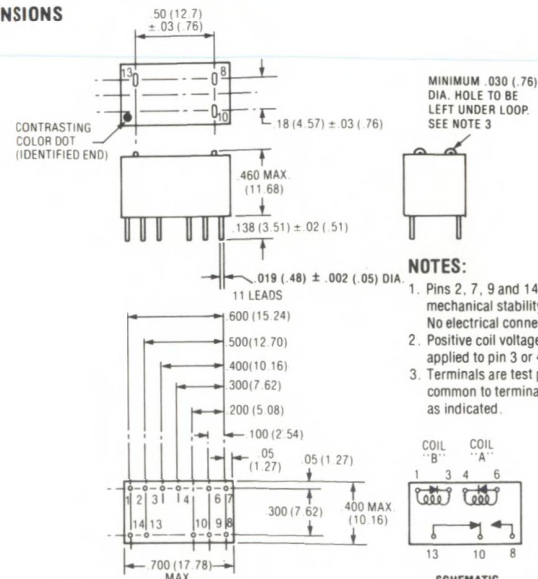

MINIMUM .030 (0.76) DIA. HOLE TO BE LEFT UNDER LOOP. SEE NOTE 3

- NOTES:**
1. Pins 2, 7, 9 and 14 are for mechanical stability only. No electrical connection required.
 2. Positive coil voltage must be applied to pin 3 or 4.
 3. Terminals are test probe points common to terminals 13, 10 and 8 as indicated.

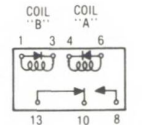

DIMENSIONS ARE SHOWN IN INCHES (MILLIMETERS)
TOLERANCES: .XX = ±.01" (0.25); .XXX = ±.005" (0.13)

SCHEMATIC (TERMINAL VIEW)
CONTACTS IN POSITION RESULTING WHEN COIL 'B' LAST ENERGIZED

OPTIONAL GROUND PIN POSITIONS

CENTIGRID RELAYS (114, 134, 172)

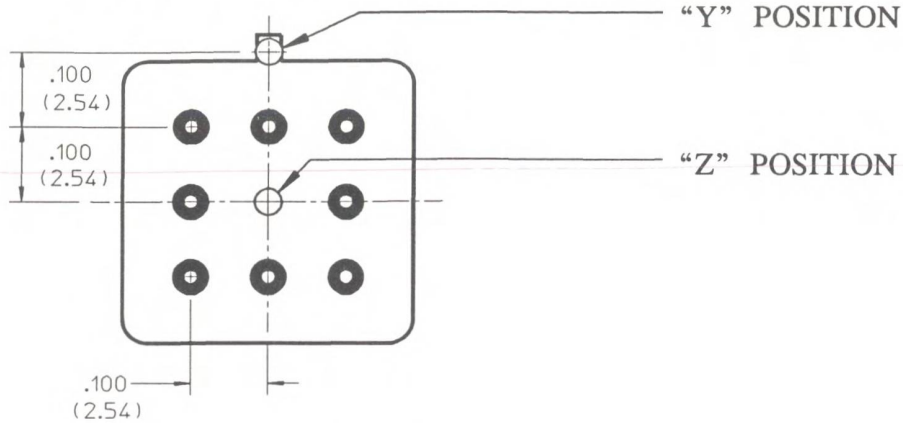

CENTIGRID RELAYS (116C, 122C, 136C, RF120, RF170)

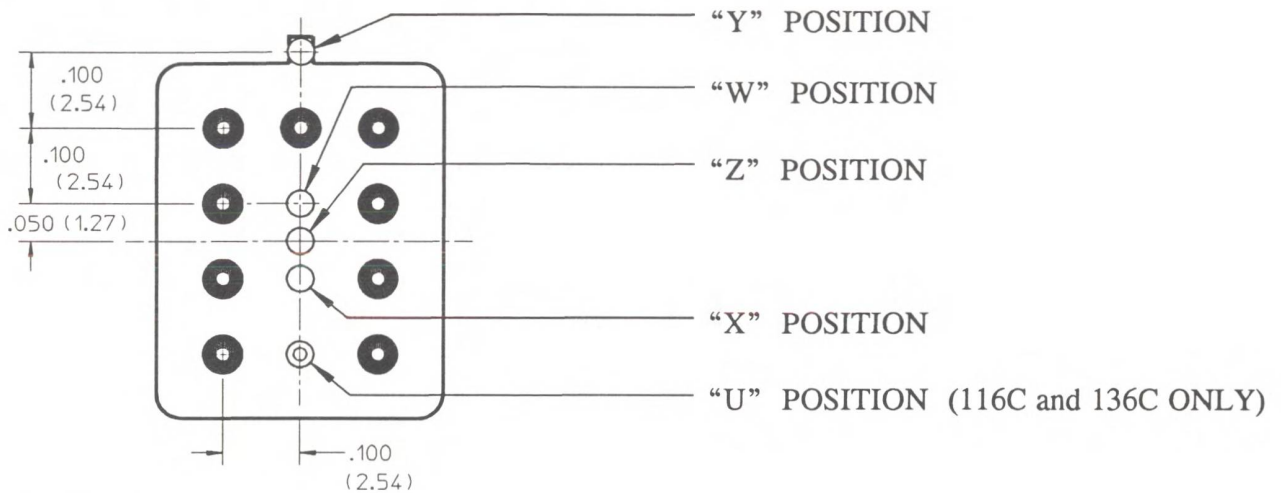

TO-5 RELAYS

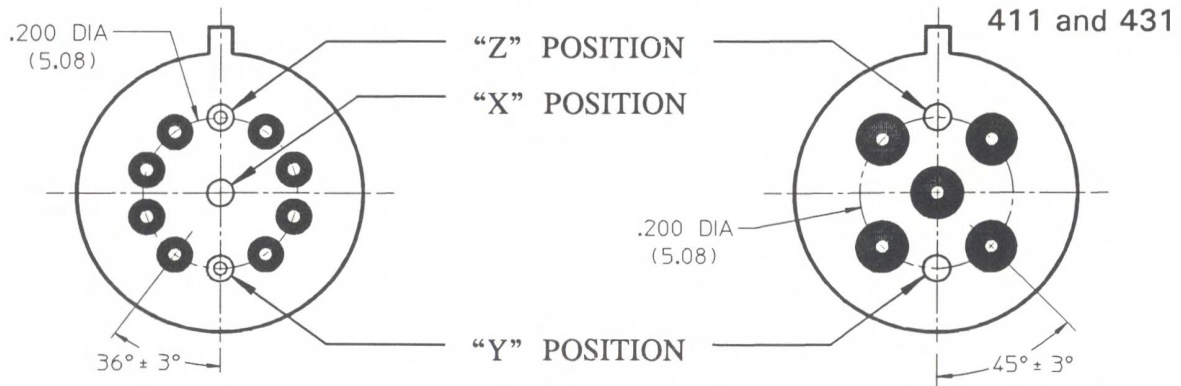

- Indicates ground pin position
- Indicates lead position
- ⊙ Indicates ground pin or lead position depending on relay type

Notes:

1. Relays are shown from the terminal view.
2. Basic dimensions are in inches and degrees. (Dimensions) are in millimeters. Tolerance: $\pm .010$ (± 0.25)
3. Ground pin positions are within .015 (0.38) dia. of true position.

SECTION II

Military Part Number to Teledyne Part Number
Cross Reference
For MIL-R-28776 and MIL-R-39016 Qualified Relays

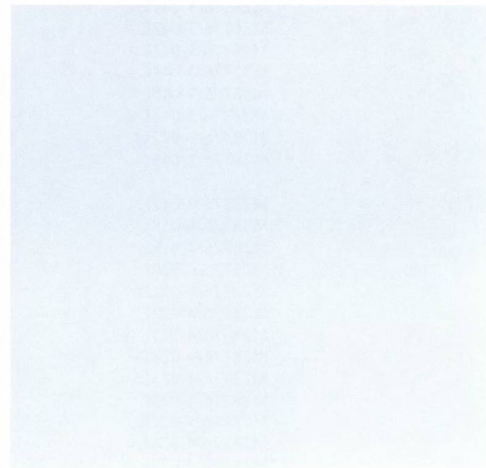
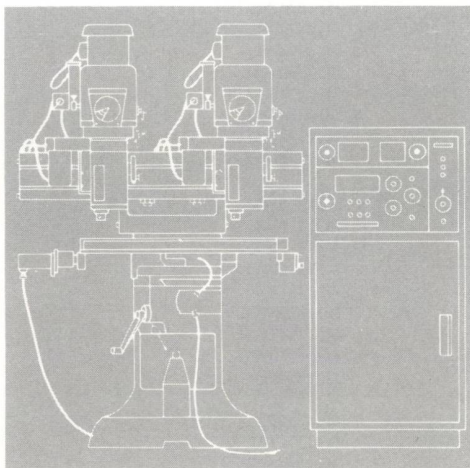
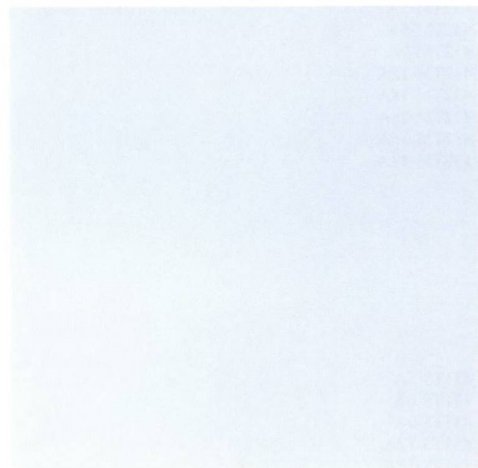
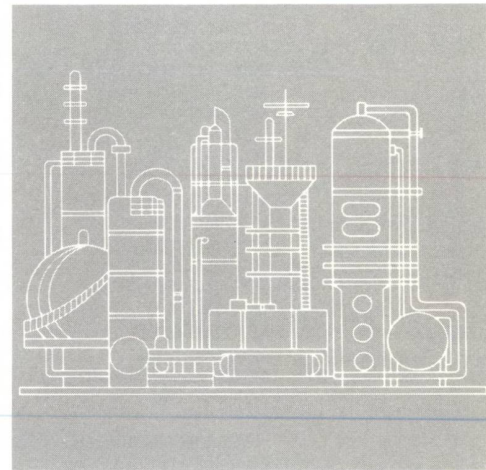
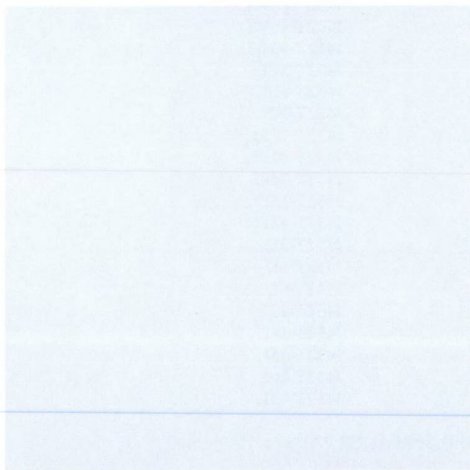
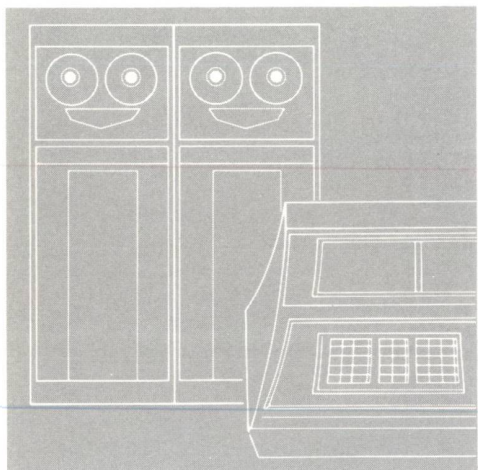
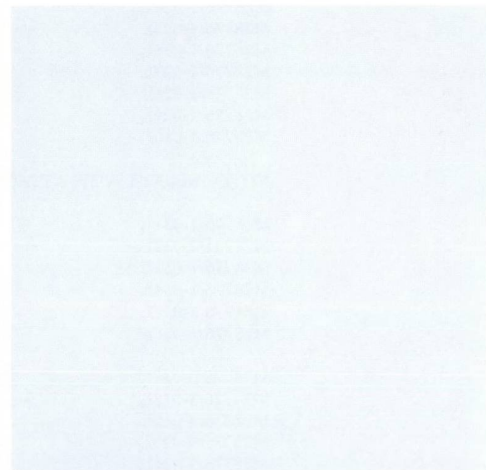
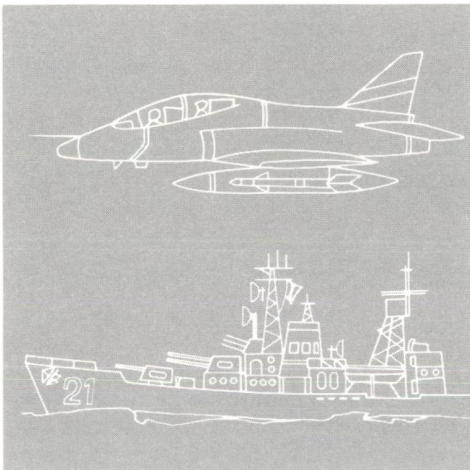
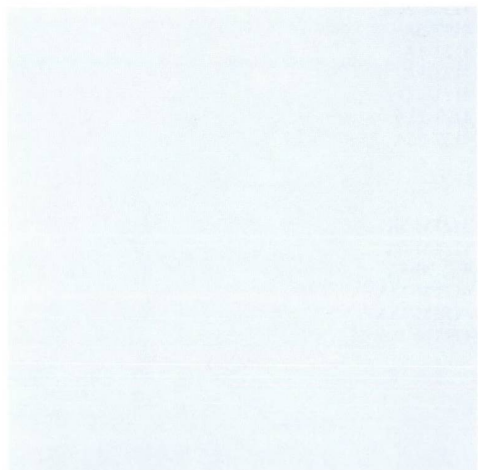

GOVERNMENT DESIGNATION	TELEDYNE DESIGNATION	COMPARABLE TELEDYNE T ² R™ (Reference Only)
M28776/1-013L	J412T-5WL	
M28776/1-014L	J412T-6WL	
M28776/1-015L	J412T-9WL	
M28776/1-016L	J412T-12WL	
M28776/1-017L	J412T-18WL	
M28776/1-018L	J412T-26WL	
M28776/1-019L	J412T-5PL	412TS-5A
M28776/1-020L	J412T-6PL	412TS-6A
M28776/1-021L	J412T-9PL	412TS-9A
M28776/1-022L	J412T-12PL	412TS-12A
M28776/1-023L	J412T-18PL	412TS-18A
M28776/1-024L	J412T-26PL	412TS-26A
M28776/1-025L	J412T-5L	412T-5A
M28776/1-026L	J412T-6L	412T-6A
M28776/1-027L	J412T-9L	412T-9A
M28776/1-028L	J412T-12L	412T-12A
M28776/1-029L	J412T-18L	412T-18A
M28776/1-030L	J412T-26L	412T-26A

NOTE: RELAYS WITH ATTACHED SPREADER PADS.

M28776/1-031L	J412TM-5L	412TM-5A
M28776/1-032L	J412TM-6L	412TM-6A
M28776/1-033L	J412TM-9L	412TM-9A
M28776/1-034L	J412TM-12L	412TM-12A
M28776/1-035L	J412TM-18L	412TM-18A
M28776/1-036L	J412TM-26L	412TM-26A

M28776/3-017L	J432T-5WL	
M28776/3-018L	J432T-6WL	
M28776/3-019L	J432T-9WL	
M28776/3-020L	J432T-12WL	
M28776/3-021L	J432T-18WL	
M28776/3-022L	J432T-26WL	
M28776/3-023L	J432T-36WL	
M28776/3-024L	J432T-48WL	
M28776/3-025L	J432T-5PL	432TS-5A
M28776/3-026L	J432T-6PL	432TS-6A
M28776/3-027L	J432T-9PL	432TS-9A
M28776/3-028L	J432T-12PL	432TS-12A
M28776/3-029L	J432T-18PL	432TS-18A
M28776/3-030L	J432T-26PL	432TS-26A
M28776/3-031L	J432T-36PL	432TS-36A
M28776/3-032L	J432T-48PL	432TS-48A
M28776/3-033L	J432T-5L	432T-5A
M28776/3-034L	J432T-6L	432T-6A
M28776/3-035L	J432T-9L	432T-9A
M28776/3-036L	J432T-12L	432T-12A
M28776/3-037L	J432T-18L	432T-18A
M28776/3-038L	J432T-26L	432T-26A
M28776/3-039L	J432T-36L	432T-36A
M28776/3-040L	J432T-48L	432T-48A

NOTE: RELAYS WITH ATTACHED SPREADER PADS

M28776/3-041L	J432TM-5L	432TM-5A
M28776/3-042L	J432TM-6L	432TM-6A
M28776/3-043L	J432TM-9L	432TM-9A
M28776/3-044L	J432TM-12L	432TM-12A
M28776/3-045L	J432TM-18L	432TM-18A
M28776/3-046L	J432TM-26L	432TM-26A
M28776/3-047L	J432TM-36L	432TM-36A
M28776/3-048L	J432TM-48L	432TM-48A

M28776/4-017L	J431T-5WL	
M28776/4-018L	J431T-6WL	
M28776/4-019L	J431T-9WL	
M28776/4-020L	J431T-12WL	
M28776/4-021L	J431T-18WL	
M28776/4-022L	J431T-26WL	
M28776/4-023L	J431T-32WL	
M28776/4-024L	J431T-40WL	
M28776/4-025L	J431T-5PL	431TS-5A
M28776/4-026L	J431T-6PL	431TS-6A
M28776/4-027L	J431T-9PL	431TS-9A
M28776/4-028L	J431T-12PL	431TS-12A
M28776/4-029L	J431T-18PL	431TS-18A
M28776/4-030L	J431T-26PL	431TS-26A
M28776/4-031L	J431T-32PL	431TS-32A

GOVERNMENT DESIGNATION	TELEDYNE DESIGNATION	COMPARABLE TELEDYNE T ² R™ (Reference Only)
M28776/4-032L	J431T-40PL	431TS-40A
M28776/4-033L	J431T-5L	431T-5A
M28776/4-034L	J431T-6L	431T-6A
M28776/4-035L	J431T-9L	431T-9A
M28776/4-036L	J431T-12L	431T-12A
M28776/4-037L	J431T-18L	431T-18A
M28776/4-038L	J431T-26L	431T-26A
M28776/4-039L	J431T-32L	431T-32A
M28776/4-040L	J431T-40L	431T-40A

NOTE: RELAYS WITH ATTACHED SPREADER PADS

M28776/4-041L	J431TM-5L	431TM-5A
M28776/4-042L	J431TM-6L	431TM-6A
M28776/4-043L	J431TM-9L	431TM-9A
M28776/4-044L	J431TM-12L	431TM-12A
M28776/4-045L	J431TM-18L	431TM-18A
M28776/4-046L	J431TM-26L	431TM-26A
M28776/4-047L	J431TM-32L	431TM-32A
M28776/4-048L	J431TM-40L	431TM-40A

M28776/5-013L	J411T-5WL	
M28776/5-014L	J411T-6WL	
M28776/5-015L	J411T-9WL	
M28776/5-016L	J411T-12WL	
M28776/5-017L	J411T-18WL	
M28776/5-018L	J411T-26WL	
M28776/5-019L	J411T-5PL	411TS-5A
M28776/5-020L	J411T-6PL	411TS-6A
M28776/5-021L	J411T-9PL	411TS-9A
M28776/5-022L	J411T-12PL	411TS-12A
M28776/5-023L	J411T-18PL	411TS-18A
M28776/5-024L	J411T-26PL	411TS-26A
M28776/5-025L	J411T-5L	411T-5A
M28776/5-026L	J411T-6L	411T-6A
M28776/5-027L	J411T-9L	411T-9A
M28776/5-028L	J411T-12L	411T-12A
M28776/5-029L	J411T-18L	411T-18A
M28776/5-030L	J411T-26L	411T-26A

NOTE: RELAYS WITH ATTACHED SPREADER PADS

M28776/5-031L	J411TM-5L	411TM-5A
M28776/5-032L	J411TM-6L	411TM-6A
M28776/5-033L	J411TM-9L	411TM-9A
M28776/5-034L	J411TM-12L	411TM-12A
M28776/5-035L	J411TM-18L	411TM-18A
M28776/5-036L	J411TM-26L	411TM-26A

M28776/6-001L	J116C-5L	116C-5A
M28776/6-002L	J116C-6L	116C-6A
M28776/6-003L	J116C-9L	116C-9A
M28776/6-004L	J116C-12L	116C-12A
M28776/6-005L	J116C-18L	116C-18A
M28776/6-006L	J116C-26L	116C-26A

NOTE: RELAYS WITH ATTACHED SPACER PADS

M28776/6-007L	J116CM9-5L	116CM9-5A
M28776/6-008L	J116CM9-6L	116CM9-6A
M28776/6-009L	J116CM9-9L	116CM9-9A
M28776/6-010L	J116CM9-12L	116CM9-12A
M28776/6-011L	J116CM9-18L	116CM9-18A
M28776/6-012L	J116CM9-26L	116CM9-26A
M28776/7-001L	J136C-5L	136C-5A
M28776/7-002L	J136C-6L	136C-6A
M28776/7-003L	J136C-9L	136C-9A
M28776/7-004L	J136C-12L	136C-12A
M28776/7-005L	J136C-18L	136C-18A
M28776/7-006L	J136C-26L	136C-26A

NOTE: RELAYS WITH ATTACHED SPACER PADS

M28776/7-007L	J136CM9-5L	136CM9-5A
M28776/7-008L	J136CM9-6L	136CM9-6A
M28776/7-009L	J136CM9-9L	136CM9-9A
M28776/7-010L	J136CM9-12L	136CM9-12A
M28776/7-011L	J136CM9-18L	136CM9-18A
M28776/7-012L	J136CM9-26L	136CM9-26A

GOVERNMENT DESIGNATION	TELEDYNE DESIGNATION	COMPARABLE TELEDYNE T ² R™ (Reference Only)
M39016/7-013L	J411-5WL	
M39016/7-014L	J411-5PL	411S-5A
M39016/7-015L	J411-6WL	
M39016/7-016L	J411-6PL	411S-6A
M39016/7-017L	J411-9WL	
M39016/7-018L	J411-9PL	411S-9A
M39016/7-019L	J411-12WL	
M39016/7-020L	J411-12PL	411S-12A
M39016/7-021L	J411-18WL	
M39016/7-022L	J411-26WL	
M39016/7-023L	J411-18PL	411S-18A
M39016/7-024L	J411-26PL	411S-26A
M39016/7-025L	J411-5L	411-5A
M39016/7-026L	J411-6L	411-6A
M39016/7-027L	J411-9L	411-9A
M39016/7-028L	J411-12L	411-12A
M39016/7-029L	J411-18L	411-18A
M39016/7-030L	J411-26L	411-26A
NOTE: RELAYS INCLUDE ATTACHED SPREADER PADS.		
M39016/7-031L	J411M3-5L	411M3-5A
M39016/7-032L	J411M3-6L	411M3-6A
M39016/7-033L	J411M3-9L	411M3-9A
M39016/7-034L	J411M3-12L	411M3-12A
M39016/7-035L	J411M3-18L	411M3-18A
M39016/7-036L	J411M3-26L	411M3-26A
M39016/8-013L	J421-5WL	
M39016/8-014L	J421-5PL	421S-5A
M39016/8-015L	J421-6WL	
M39016/8-016L	J421-6PL	421S-6A
M39016/8-017L	J421-9WL	
M39016/8-018L	J421-9PL	421S-9A
M39016/8-019L	J421-12WL	
M39016/8-020L	J421-12PL	421S-12A
M39016/8-021L	J421-18WL	
M39016/8-022L	J421-18PL	421S-18A
M39016/8-023L	J421-26WL	
M39016/8-024L	J421-26PL	421S-26A
M39016/8-025L	J421-5L	421-5A
M39016/8-026L	J421-6L	421-6A
M39016/8-027L	J421-9L	421-9A
M39016/8-028L	J421-12L	421-12A
M39016/8-029L	J421-18L	421-18A
M39016/8-030L	J421-26L	421-26A
NOTE: RELAYS INCLUDE ATTACHED SPREADER PADS.		
M39016/8-031L	J421M-5L	421M-5A
M39016/8-032L	J421M-6L	421M-6A
M39016/8-033L	J421M-9L	421M-9A
M39016/8-034L	J421M-12L	421M-12A
M39016/8-035L	J421M-18L	421M-18A
M39016/8-036L	J421M-26L	421M-26A
M39016/9-013L	J412-5WL	
M39016/9-014L	J412-6WL	
M39016/9-015L	J412-9WL	
M39016/9-016L	J412-12WL	
M39016/9-017L	J412-18WL	
M39016/9-018L	J412-26WL	
M39016/9-019L	J412-5PL	412S-5A
M39016/9-020L	J412-6PL	412S-6A
M39016/9-021L	J412-9PL	412S-9A
M39016/9-022L	J412-12PL	412S-12A
M39016/9-023L	J412-18PL	412S-18A
M39016/9-024L	J412-26PL	412S-26A
M39016/9-051L	J412-30WL	
M39016/9-052L	J412-30PL	412S-30A
M39016/9-057L	J412-5L	412-5A
M39016/9-058L	J412-6L	412-6A
M39016/9-059L	J412-9L	412-9A
M39016/9-060L	J412-12L	412-12A
M39016/9-061L	J412-18L	412-18A
M39016/9-062L	J412-26L	412-26A
M39016/9-063L	J412-30L	412-30A
M39016/9-085L	J412Y-5L	412Y-5A
M39016/9-086L	J412Y-6L	412Y-6A

GOVERNMENT DESIGNATION	TELEDYNE DESIGNATION	COMPARABLE TELEDYNE T ² R™ (Reference Only)
M39016/9-087L	J412Y-9L	412Y-9A
M39016/9-088L	J412Y-12L	412Y-12A
M39016/9-089L	J412Y-18L	412Y-18A
M39016/9-090L	J412Y-26L	412Y-26A
M39016/9-091L	J412Y-30L	412Y-30A

NOTE: RELAYS INCLUDE ATTACHED SPREADER PADS.

M39016/9-071L	J412M-5L	412M-5A
M39016/9-072L	J412M-6L	412M-6A
M39016/9-073L	J412M-9L	412M-9A
M39016/9-074L	J412M-12L	412M-12A
M39016/9-075L	J412M-18L	412M-18A
M39016/9-076L	J412M-26L	412M-26A
M39016/9-077L	J412M-30L	412M-30A
M39016/9-099L	J412YM-5L	412YM-5A
M39016/9-100L	J412YM-6L	412YM-6A
M39016/9-101L	J412YM-9L	412YM-9A
M39016/9-102L	J412YM-12L	412YM-12A
M39016/9-103L	J412YM-18L	412YM-18A
M39016/9-104L	J412YM-26L	412YM-26A
M39016/9-105L	J412YM-30L	412YM-30A

M39016/10-017L	J431-5WL	
M39016/10-018L	J431-5PL	431S-5A
M39016/10-019L	J431-6WL	
M39016/10-020L	J431-6PL	431S-6A
M39016/10-021L	J431-12WL	
M39016/10-022L	J431-12PL	431S-12A
M39016/10-023L	J431-26WL	
M39016/10-024L	J431-26PL	431S-26A
M39016/10-025L	J431-32WL	
M39016/10-026L	J431-32PL	431S-32A

M39016/10-027L	J431-40WL	
M39016/10-028L	J431-40PL	431S-40A
M39016/10-029L	J431-9WL	
M39016/10-030L	J431-9PL	431S-9A
M39016/10-031L	J431-18WL	
M39016/10-032L	J431-18PL	431S-18A
M39016/10-033L	J431-5L	431-5A
M39016/10-034L	J431-6L	431-6A
M39016/10-035L	J431-12L	431-12A
M39016/10-036L	J431-26L	431-26A
M39016/10-037L	J431-32L	431-32A
M39016/10-038L	J431-40L	431-40A
M39016/10-039L	J431-9L	431-9A
M39016/10-040L	J431-18L	431-18A

NOTE: RELAYS INCLUDE ATTACHED SPREADER PADS.

M39016/10-041L	J431M3-5L	431M3-5A
M39016/10-042L	J431M3-6L	431M3-6A
M39016/10-043L	J431M3-12L	431M3-12A
M39016/10-044L	J431M3-26L	431M3-26A
M39016/10-045L	J431M3-32L	431M3-32A
M39016/10-046L	J431M3-40L	431M3-40A
M39016/10-047L	J431M3-9L	431M3-9A
M39016/10-048L	J431M3-18L	431M3-18A

M39016/11-017L	J432-5WL	
M39016/11-018L	J432-5PL	432S-5A
M39016/11-019L	J432-6WL	
M39016/11-020L	J432-6PL	432S-6A
M39016/11-021L	J432-12WL	
M39016/11-022L	J432-12PL	432S-12A
M39016/11-023L	J432-26WL	
M39016/11-024L	J432-26PL	432S-26A
M39016/11-025L	J432-36WL	
M39016/11-026L	J432-36PL	432S-36A
M39016/11-027L	J432-48WL	
M39016/11-028L	J432-48PL	432S-48A
M39016/11-029L	J432-9WL	
M39016/11-030L	J432-9PL	432S-9A
M39016/11-031L	J432-18WL	
M39016/11-032L	J432-18PL	432S-18A
M39016/11-033L	J432-5L	432-5A
M39016/11-034L	J432-6L	432-6A
M39016/11-035L	J432-12L	432-12A

GOVERNMENT DESIGNATION	TELEDYNE DESIGNATION	COMPARABLE TELEDYNE T ² R™ (Reference Only)
M39016/11-036L	J432-26L	432-26A
M39016/11-037L	J432-36L	432-36A
M39016/11-038L	J432-48L	432-48A
M39016/11-039L	J432-9L	432-9A
M39016/11-040L	J432-18L	432-18A

NOTE: RELAYS INCLUDE ATTACHED SPREADER PADS.

M39016/11-041L	J432M-5L	432M-5A
M39016/11-042L	J432M-6L	432M-6A
M39016/11-043L	J432M-12L	432M-12A
M39016/11-044L	J432M-26L	432M-26A
M39016/11-045L	J432M-36L	432M-36A
M39016/11-046L	J432M-48L	432M-48A
M39016/11-047L	J432M-9L	432M-9A
M39016/11-048L	J432M-18L	432M-18A

M39016/12-025L	J420-5WL	
M39016/12-026L	J420-6WL	
M39016/12-027L	J420-9WL	
M39016/12-028L	J420-12WL	
M39016/12-029L	J420-18WL	
M39016/12-030L	J420-26WL	
M39016/12-031L	J422-5WL	
M39016/12-032L	J422-6WL	
M39016/12-033L	J422-9WL	
M39016/12-034L	J422-12WL	
M39016/12-035L	J422-18WL	
M39016/12-036L	J422-26WL	
M39016/12-037L	J420-5PL	420S-5A
M39016/12-038L	J420-6PL	420S-6A
M39016/12-039L	J420-9PL	420S-9A
M39016/12-040L	J420-12PL	420S-12A
M39016/12-041L	J420-18PL	420S-18A
M39016/12-042L	J420-26PL	420S-26A
M39016/12-043L	J422-5PL	422S-5A
M39016/12-044L	J422-6PL	422S-6A
M39016/12-045L	J422-9PL	422S-9A
M39016/12-046L	J422-12PL	422S-12A
M39016/12-047L	J422-18PL	422S-18A
M39016/12-048L	J422-26PL	422S-26A
M39016/12-049L	J420-5L	420-5A
M39016/12-050L	J420-6L	420-6A
M39016/12-051L	J420-9L	420-9A
M39016/12-052L	J420-12L	420-12A
M39016/12-053L	J420-18L	420-18A
M39016/12-054L	J420-26L	420-26A
M39016/12-055L	J422-5L	422-5A
M39016/12-056L	J422-6L	422-6A
M39016/12-057L	J422-9L	422-9A
M39016/12-058L	J422-12L	422-12A
M39016/12-059L	J422-18L	422-18A
M39016/12-060L	J422-26L	422-26A
M39016/12-073L	J422X-5L	422X-5A
M39016/12-074L	J422X-6L	422X-6A
M39016/12-075L	J422X-9L	422X-9A
M39016/12-076L	J422X-12L	422X-12A
M39016/12-077L	J422X-18L	422X-18A
M39016/12-078L	J422X-26L	422X-26A

NOTE: RELAYS INCLUDE ATTACHED SPREADER PADS.

M39016/12-061L	J420M-5L	420M-5A
M39016/12-062L	J420M-6L	420M-6A
M39016/12-063L	J420M-9L	420M-9A
M39016/12-064L	J420M-12L	420M-12A
M39016/12-065L	J420M-18L	420M-18A
M39016/12-066L	J420M-26L	420M-26A
M39016/12-067L	J422M-5L	422M-5A
M39016/12-068L	J422M-6L	422M-6A
M39016/12-069L	J422M-9L	422M-9A
M39016/12-070L	J422M-12L	422M-12A
M39016/12-071L	J422M-18L	422M-18A
M39016/12-072L	J422M-26L	422M-26A

M39016/15-029L	J412D-6WL	
M39016/15-030L	J412D-9WL	
M39016/15-031L	J412D-12WL	
M39016/15-032L	J412D-18WL	

GOVERNMENT DESIGNATION	TELEDYNE DESIGNATION	COMPARABLE TELEDYNE T ² R™ (Reference Only)
M39016/15-033L	J412D-26WL	
M39016/15-034L	J412D-5WL	
M39016/15-035L	J412D-6PL	412DS-6A
M39016/15-036L	J412D-9PL	412DS-9A
M39016/15-037L	J412D-12PL	412DS-12A
M39016/15-038L	J421D-18PL	412DS-18A
M39016/15-039L	J412D-26PL	412DS-26A
M39016/15-040L	J412D-5PL	412DS-5A
M39016/15-065L	J412DY-6WL	
M39016/15-066L	J412DY-9WL	
M39016/15-067L	J412DY-12WL	
M39016/15-068L	J421DY-18WL	
M39016/15-069L	J412DY-26WL	
M39016/15-070L	J412DY-5WL	
M39016/15-077L	J412D-6L	412D-6A
M39016/15-078L	J412D-9L	412D-9A
M39016/15-079L	J412D-12L	412D-12A
M39016/15-080L	J412D-18L	412D-18A
M39016/15-081L	J412D-26L	412D-26A
M39016/15-082L	J412D-5L	412D-5A
M39016/15-089L	J412DY-6L	412DY-6A
M39016/15-090L	J412DY-9L	412DY-9A
M39016/15-091L	J412DY-12L	412DY-12A
M39016/15-092L	J412DY-18L	412DY-18A
M39016/15-093L	J412DY-26L	412DY-26A
M39016/15-094L	J412DY-5L	412DY-5A

NOTE: RELAYS INCLUDE ATTACHED SPREADER PADS.

M39016/15-101L	J412DM-6L	412DM-6A
M39016/15-102L	J412DM-9L	412DM-9A
M39016/15-103L	J412DM-12L	412DM-12A
M39016/15-104L	J412DM-18L	412DM-18A
M39016/15-105L	J412DM-26L	412DM-26A
M39016/15-106L	J412DM-5L	412DM-5A
M39016/15-113L	J412DYM-6L	412DYM-6A
M39016/15-114L	J412DYM-9L	412DYM-9A
M39016/15-115L	J412DYM-12L	412DYM-12A
M39016/15-116L	J412DYM-18L	412DYM-18A
M39016/15-117L	J412DYM-26L	412DYM-26A
M39016/15-118L	J412DYM-5L	412DYM-5A
M39016/15-125L	J412DM2-6L	412DM2-6A
M39016/15-126L	J412DM2-9L	412DM2-9A
M39016/15-127L	J412DM2-12L	412DM2-12A
M39016/15-128L	J412DM2-18L	412DM2-18A
M39016/15-129L	J412DM2-26L	412DM2-26A
M39016/15-130L	J412DM2-5L	412DM2-5A
M39016/16-017L	J432D-5WL	
M39016/16-018L	J432D-6WL	
M39016/16-019L	J432D-12WL	
M39016/16-020L	J432D-26WL	
M39016/16-021L	J432D-36WL	
M39016/16-022L	J432D-48WL	
M39016/16-023L	J432D-9WL	
M39016/16-024L	J432D-18WL	
M39016/16-025L	J432D-5PL	432DS-5A
M39016/16-026L	J432D-6PL	432DS-6A
M39016/16-027L	J432D-12PL	432DS-12A
M39016/16-028L	J432D-26PL	432DS-26A
M39016/16-029L	J432D-36PL	432DS-36A
M39016/16-030L	J432D-48PL	432DS-48A
M39016/16-031L	J432D-9PL	432DS-9A
M39016/16-032L	J432D-18PL	432DS-18A
M39016/16-033L	J432D-5L	432D-5A
M39016/16-034L	J432D-6L	432D-6A
M39016/16-035L	J432D-12L	432D-12A
M39016/16-036L	J432D-26L	432D-26A
M39016/16-037L	J432D-36L	432D-36A
M39016/16-038L	J432D-48L	432D-48A
M39016/16-039L	J432D-9L	432D-9A
M39016/16-040L	J432D-18L	432D-18A

NOTE: RELAYS INCLUDE ATTACHED SPREADER PADS.

M39016/16-041L	J432DM-5L	432DM-5A
M39016/16-042L	J432DM-6L	432DM-6A
M39016/16-043L	J432DM-12L	432DM-12A
M39016/16-044L	J432DM-26L	432DM-26A

GOVERNMENT DESIGNATION	TELEDYNE DESIGNATION	COMPARABLE TELEDYNE T ² R™ (Reference Only)
M39016/16-045L	J432DM-36L	432DM-36A
M39016/16-046L	J432DM-48L	432DM-48A
M39016/16-047L	J432DM-9L	432DM-9A
M39016/16-048L	J432DM-18L	432DM-18A
M39016/17-025L	J114-5PL	114S-5A
M39016/17-026L	J114-6PL	114S-6A
M39016/17-027L	J114-9PL	114S-9A
M39016/17-028L	J114-12PL	114S-12A
M39016/17-029L	J114-18PL	114S-18A
M39016/17-030L	J114-26PL	114S-26A
M39016/17-031L	J114-5L	114-5A
M39016/17-032L	J114-6L	114-6A
M39016/17-033L	J114-9L	114-9A
M39016/17-034L	J114-12L	114-12A
M39016/17-035L	J114-18L	114-18A
M39016/17-036L	J114-26L	114-26A
M39016/17-043L	J114Z-5L	114Z-5A
M39016/17-044L	J114Z-6L	114Z-6A
M39016/17-045L	J114Z-9L	114Z-9A
M39016/17-046L	J114Z-12L	114Z-12A
M39016/17-047L	J114Z-18L	114Z-18A
M39016/17-048L	J114Z-26L	114Z-26A

NOTE: RELAYS INCLUDE ATTACHED SPACER PADS.

M39016/17-037L	J114M4-5L	114M4-5A
M39016/17-038L	J114M4-6L	114M4-6A
M39016/17-039L	J114M4-9L	114M4-9A
M39016/17-040L	J114M4-12L	114M4-12A
M39016/17-041L	J114M4-18L	114M4-18A
M39016/17-042L	J114M4-26L	114M4-26A
M39016/17-049L	J114ZM4-5L	114ZM4-5A
M39016/17-050L	J114ZM4-6L	114ZM4-6A
M39016/17-051L	J114ZM4-9L	114ZM4-9A
M39016/17-052L	J114ZM4-12L	114ZM4-12A
M39016/17-053L	J114ZM4-18L	114ZM4-18A
M39016/17-054L	J114ZM4-26L	114ZM4-26A
M39016/18-025L	J114D-5PL	114DS-5A
M39016/18-026L	J114D-6PL	114DS-6A
M39016/18-027L	J114D-9PL	114DS-9A
M39016/18-028L	J114D-12PL	114DS-12A
M39016/18-029L	J114D-18PL	114DS-18A
M39016/18-030L	J114D-26PL	114DS-26A
M39016/18-031L	J114D-5L	114D-5A
M39016/18-032L	J114D-6L	114D-6A
M39016/18-033L	J114D-9L	114D-9A
M39016/18-034L	J114D-12L	114D-12A
M39016/18-035L	J114D-18L	114D-18A
M39016/18-036L	J114D-26L	114D-26A
M39016/18-043L	J114DZ-5L	114DZ-5A
M39016/18-044L	J114DZ-6L	114DZ-6A
M39016/18-045L	J114DZ-9L	114DZ-9A
M39016/18-046L	J114DZ-12L	114DZ-12A
M39016/18-047L	J114DZ-18L	114DZ-18A
M39016/18-048L	J114DZ-26L	114DZ-26A

NOTE: RELAYS INCLUDE ATTACHED SPACER PADS.

M39016/18-037L	J114DM4-5L	114DM4-5A
M39016/18-038L	J114DM4-6L	114DM4-6A
M39016/18-039L	J114DM4-9L	114DM4-9A
M39016/18-040L	J114DM4-12L	114DM4-12A
M39016/18-041L	J114DM4-18L	114DM4-18A
M39016/18-042L	J114DM4-26L	114DM4-26A
M39016/18-049L	J114DZM4-5L	114DZM4-5A
M39016/18-050L	J114DZM4-6L	114DZM4-6A
M39016/18-051L	J114DZM4-9L	114DZM4-9A
M39016/18-052L	J114DZM4-12L	114DZM4-12A
M39016/18-053L	J114DZM4-18L	114DZM4-18A
M39016/18-054L	J114DZM4-26L	114DZM4-26A
M39016/19-025L	J114DD-5PL	114DDS-5A
M39016/19-026L	J114DD-6PL	114DDS-6A
M39016/19-027L	J114DD-9PL	114DDS-9A
M39016/19-028L	J114DD-12PL	114DDS-12A
M39016/19-029L	J114DD-18PL	114DDS-18A
M39016/19-030L	J114DD-26PL	114DDS-26A

GOVERNMENT DESIGNATION	TELEDYNE DESIGNATION	COMPARABLE TELEDYNE T ² R™ (Reference Only)
M39016/19-031L	J114DD-5L	114DD-5A
M39016/19-032L	J114DD-6L	114DD-6A
M39016/19-033L	J114DD-9L	114DD-9A
M39016/19-034L	J114DD-12L	114DD-12A
M39016/19-035L	J114DD-18L	114DD-18A
M39016/19-036L	J114DD-26L	114DD-26A
M39016/19-043L	J114DDZ-5L	114DDZ-5A
M39016/19-044L	J114DDZ-6L	114DDZ-6A
M39016/19-045L	J114DDZ-9L	114DDZ-9A
M39016/19-046L	J114DDZ-12L	114DDZ-12A
M39016/19-047L	J114DDZ-18L	114DDZ-18A
M39016/19-048L	J114DDZ-26L	114DDZ-26A

NOTE: RELAYS INCLUDE ATTACHED SPACER PADS.

M39016/19-037L	J114DDM4-5L	114DDM4-5A
M39016/19-038L	J114DDM4-6L	114DDM4-6A
M39016/19-039L	J114DDM4-9L	114DDM4-9A
M39016/19-040L	J114DDM4-12L	114DDM4-12A
M39016/19-041L	J114DDM4-18L	114DDM4-18A
M39016/19-042L	J114DDM4-26L	114DDM4-26A
M39016/19-049L	J114DDZM4-5L	114DDZM4-5A
M39016/19-050L	J114DDZM4-6L	114DDZM4-6A
M39016/19-051L	J114DDZM4-9L	114DDZM4-9A
M39016/19-052L	J114DDZM4-12L	114DDZM4-12A
M39016/19-053L	J114DDZM4-18L	114DDZM4-18A
M39016/19-054L	J114DDZM4-26L	114DDZM4-26A

M39016/20-007L	J412DD-5WL	
M39016/20-008L	J412DD-6WL	
M39016/20-009L	J412DD-9WL	
M39016/20-010L	J412DD-12WL	
M39016/20-011L	J412DD-18WL	
M39016/20-012L	J412DD-26WL	
M39016/20-037L	J412DD-5PL	412DDS-5A
M39016/20-038L	J412DD-6PL	412DDS-6A
M39016/20-039L	J412DD-9PL	412DDS-9A
M39016/20-040L	J412DD-12PL	412DDS-12A
M39016/20-041L	J412DD-18PL	412DDS-18A
M39016/20-042L	J412DD-26PL	412DDS-26A
M39016/20-049L	J412DD-5L	412DD-5A
M39016/20-050L	J412DD-6L	412DD-6A
M39016/20-051L	J412DD-9L	412DD-9A
M39016/20-052L	J412DD-12L	412DD-12A
M39016/20-053L	J412DD-18L	412DD-18A
M39016/20-054L	J412DD-26L	412DD-26A

NOTE: RELAYS INCLUDE ATTACHED SPREADER PADS.

M39016/20-061L	J412DDM-5L	412DDM-5A
M39016/20-062L	J412DDM-6L	412DDM-6A
M39016/20-063L	J412DDM-9L	412DDM-9A
M39016/20-064L	J412DDM-12L	412DDM-12A
M39016/20-065L	J412DDM-18L	412DDM-18A
M39016/20-066L	J412DDM-26L	412DDM-26A
M39016/20-073L	J412DDM2-5L	412DDM2-5A
M39016/20-074L	J412DDM2-6L	412DDM2-6A
M39016/20-075L	J412DDM2-9L	412DDM2-9A
M39016/20-076L	J412DDM2-12L	412DDM2-12A
M39016/20-077L	J412DDM2-18L	412DDM2-18A
M39016/20-078L	J412DDM2-26L	412DDM2-26A

M39016/21-007L	J432DD-5WL	
M39016/21-008L	J432DD-6WL	
M39016/21-009L	J432DD-9WL	
M39016/21-010L	J432DD-12WL	
M39016/21-011L	J432DD-18WL	
M39016/21-012L	J432DD-26WL	
M39016/21-019L	J432DD-5PL	432DDS-5A
M39016/21-020L	J432DD-6PL	432DDS-6A
M39016/21-021L	J432DD-9PL	432DDS-9A
M39016/21-022L	J432DD-12PL	432DDS-12A
M39016/21-023L	J432DD-18PL	432DDS-18A
M39016/21-024L	J432DD-26PL	432DDS-26A
M39016/21-029L	J432DD-36WL	
M39016/21-030L	J432DD-48WL	
M39016/21-031L	J432DD-36PL	432DDS-36A
M39016/21-032L	J432DD-48PL	432DDS-48A
M39016/21-033L	J432DD-5L	432DD-5A

GOVERNMENT DESIGNATION	TELEDYNE DESIGNATION	COMPARABLE TELEDYNE T ² R™ (Reference Only)
M39016/21-034L	J432DD-6L	432DD-6A
M39016/21-035L	J432DD-9L	432DD-9A
M39016/21-036L	J432DD-12L	432DD-12A
M39016/21-037L	J432DD-18L	432DD-18A
M39016/21-038L	J432DD-26L	432DD-26A
M39016/21-039L	J432DD-36L	432DD-36A
M39016/21-040L	J432DD-48L	432DD-48A

NOTE: RELAYS INCLUDE ATTACHED SPREADER PADS.

M39016/21-041L	J432DDM-5L	432DDM-5A
M39016/21-042L	J432DDM-6L	432DDM-6A
M39016/21-043L	J432DDM-9L	432DDM-9A
M39016/21-044L	J432DDM-12L	432DDM-12A
M39016/21-045L	J432DDM-18L	432DDM-18A
M39016/21-046L	J432DDM-26L	432DDM-26A
M39016/21-047L	J432DDM-36L	432DDM-36A
M39016/21-048L	J432DDM-48L	432DDM-48A

M39016/23-013L	J411D-5WL	
M39016/23-014L	J411D-6WL	
M39016/23-015L	J411D-9WL	
M39016/23-016L	J411D-12WL	
M39016/23-017L	J411D-18WL	
M39016/23-018L	J411D-26WL	
M39016/23-019L	J411D-5PL	411DS-5A
M39016/23-020L	J411D-6PL	411DS-6A
M39016/23-021L	J411D-9PL	411DS-9A
M39016/23-022L	J411D-12PL	411DS-12A
M39016/23-023L	J411D-18PL	411DS-18A
M39016/23-024L	J411D-26PL	411DS-26A
M39016/23-025L	J411D-5L	411D-5A
M39016/23-026L	J411D-6L	411D-6A
M39016/23-027L	J411D-9L	411D-9A
M39016/23-028L	J411D-12L	411D-12A
M39016/23-029L	J411D-18L	411D-18A
M39016/23-030L	J411D-26L	411D-26A

NOTE: RELAYS INCLUDE ATTACHED SPREADER PADS.

M39016/23-031L	J411DM3-5L	411DM3-5A
M39016/23-032L	J411DM3-6L	411DM3-6A
M39016/23-033L	J411DM3-9L	411DM3-9A
M39016/23-034L	J411DM3-12L	411DM3-12A
M39016/23-035L	J411DM3-18L	411DM3-18A
M39016/23-036L	J411DM3-26L	411DM3-26A

M39016/24-013L	J411DD-5WL	
M39016/24-014L	J411DD-6WL	
M39016/24-015L	J411DD-9WL	
M39016/24-016L	J411DD-12WL	
M39016/24-017L	J411DD-18WL	
M39016/24-018L	J411DD-26WL	
M39016/24-019L	J411DD-5PL	411DDS-5A
M39016/24-020L	J411DD-6PL	411DDS-6A
M39016/24-021L	J411DD-9PL	411DDS-9A
M39016/24-022L	J411DD-12PL	411DDS-12A
M39016/24-023L	J411DD-18PL	411DDS-18A
M39016/24-024L	J411DD-26PL	411DDS-26A
M39016/24-025L	J411DD-5L	411DD-5A
M39016/24-026L	J411DD-6L	411DD-6A
M39016/24-027L	J411DD-9L	411DD-9A
M39016/24-028L	J411DD-12L	411DD-12A
M39016/24-029L	J411DD-18L	411DD-18A
M39016/24-030L	J411DD-26L	411DD-26A

NOTE: RELAYS INCLUDE ATTACHED SPREADER PADS.

M39016/24-031L	J411DDM3-5L	411DDM3-5A
M39016/24-032L	J411DDM3-6L	411DDM3-6A
M39016/24-033L	J411DDM3-9L	411DDM3-9A
M39016/24-034L	J411DDM3-12L	411DDM3-12A
M39016/24-035L	J411DDM3-18L	411DDM3-18A
M39016/24-036L	J411DDM3-26L	411DDM3-26A

M39016/25-017L	J431D-5WL	
M39016/25-018L	J431D-6WL	
M39016/25-019L	J431D-12WL	
M39016/25-020L	J431D-26WL	

GOVERNMENT DESIGNATION	TELEDYNE DESIGNATION	COMPARABLE TELEDYNE T ² R™ (Reference Only)
M39016/25-021L	J431D-32WL	
M39016/25-022L	J431D-40WL	
M39016/25-023L	J431D-9WL	
M39016/25-024L	J431D-18WL	
M39016/25-025L	J431D-5PL	431DS-5A
M39016/25-026L	J431D-6PL	431DS-6A
M39016/25-027L	J431D-12PL	431DS-12A
M39016/25-028L	J431D-26PL	431DS-26A
M39016/25-029L	J431D-32PL	431DS-32A
M39016/25-030L	J431D-40PL	431DS-40A
M39016/25-031L	J431D-9PL	431DS-9A
M39016/25-032L	J431D-18PL	431DS-18A
M39016/25-033L	J431D-5L	431D-5A
M39016/25-034L	J431D-6L	431D-6A
M39016/25-035L	J431D-12L	431D-12A
M39016/25-036L	J431D-26L	431D-26A
M39016/25-037L	J431D-32L	431D-32A
M39016/25-038L	J431D-40L	431D-40A
M39016/25-039L	J431D-9L	431D-9A
M39016/25-040L	J431D-18L	431D-18A

NOTE RELAYS INCLUDE ATTACHED SPREADER PADS.

M39016/25-041L	J431DM3-5L	431DM3-5A
M39016/25-042L	J431DM3-6L	431DM3-6A
M39016/25-043L	J431DM3-12L	431DM3-12A
M39016/25-044L	J431DM3-26L	431DM3-26A
M39016/25-045L	J431DM3-32L	431DM3-32A
M39016/25-046L	J431DM3-40L	431DM3-40A
M39016/25-047L	J431DM3-9L	431DM3-9A
M39016/25-048L	J431DM3-18L	431DM3-18A

M39016/26-017L	J431DD-5WL	
M39016/26-018L	J431DD-6WL	
M39016/26-019L	J431DD-12WL	
M39016/26-020L	J431DD-26WL	
M39016/26-021L	J431DD-32WL	
M39016/26-022L	J431DD-40WL	
M39016/26-023L	J431DD-9WL	
M39016/26-024L	J431DD-18WL	
M39016/26-025L	J431DD-5PL	431DDS-5A
M39016/26-026L	J431DD-6PL	431DDS-6A
M39016/26-027L	J431DD-12PL	431DDS-12A
M39016/26-028L	J431DD-26PL	431DDS-26A
M39016/26-029L	J431DD-32PL	431DDS-32A
M39016/26-030L	J431DD-40PL	431DDS-40A
M39016/26-031L	J431DD-9PL	431DDS-9A
M39016/26-032L	J431DD-18PL	431DDS-18A
M39016/26-033L	J431DD-5L	431DD-5A
M39016/26-034L	J431DD-6L	431DD-6A
M39016/26-035L	J431DD-12L	431DD-12A
M39016/26-036L	J431DD-26L	431DD-26A
M39016/26-037L	J431DD-32L	431DD-32A
M39016/26-038L	J431DD-40L	431DD-40A
M39016/26-039L	J431DD-9L	431DD-9A
M39016/26-040L	J431DD-18L	431DD-18A

NOTE: RELAYS INCLUDE ATTACHED SPREADER PADS.

M39016/26-041L	J431DDM3-5L	431DDM3-5A
M39016/26-042L	J431DDM3-6L	431DDM3-6A
M39016/26-043L	J431DDM3-12L	431DDM3-12A
M39016/26-044L	J431DDM3-26L	431DDM3-26A
M39016/26-045L	J431DDM3-32L	431DDM3-32A
M39016/26-046L	J431DDM3-40L	431DDM3-40A
M39016/26-047L	J431DDM3-9L	431DDM3-9A
M39016/26-048L	J431DDM3-18L	431DDM3-18A

M39016/27-013L	J421D-5WL	
M39016/27-014L	J421D-6WL	
M39016/27-015L	J421D-9WL	
M39016/27-016L	J421D-12WL	
M39016/27-017L	J421D-18WL	
M39016/27-018L	J421D-26WL	
M39016/27-019L	J421D-5PL	421DS-5A
M39016/27-020L	J421D-6PL	421DS-6A
M39016/27-021L	J421D-9PL	421DS-9A
M39016/27-022L	J421D-12PL	421DS-12A
M39016/27-023L	J421D-18PL	421DS-18A

GOVERNMENT DESIGNATION	TELEDYNE DESIGNATION	COMPARABLE TELEDYNE T ² R™ (Reference Only)
M39016/27-024L	J421D-26PL	421DS-26A
M39016/27-025L	J421D-5L	421D-5A
M39016/27-026L	J421D-6L	421D-6A
M39016/27-027L	J421D-9L	421D-9A
M39016/27-028L	J421D-12L	421D-12A
M39016/27-029L	J421D-18L	421D-18A
M39016/27-030L	J421D-26L	421D-26A
NOTE: RELAYS INCLUDE ATTACHED SPREADER PADS.		
M39016/27-031L	J421DM-5L	421DM-5A
M39016/27-032L	J421DM-6L	421DM-6A
M39016/27-033L	J421DM-9L	421DM-9A
M39016/27-034L	J421DM-12L	421DM-12A
M39016/27-035L	J421DM-18L	421DM-18A
M39016/27-036L	J421DM-26L	421DM-26A
M39016/28-013L	J421DD-5WL	
M39016/28-014L	J421DD-6WL	
M39016/28-015L	J421DD-9WL	
M39016/28-016L	J421DD-12WL	
M39016/28-017L	J421DD-18WL	
M39016/28-018L	J421DD-26WL	
M39016/28-019L	J421DD-5PL	421DDS-5A
M39016/28-020L	J421DD-6PL	421DDS-6A
M39016/28-021L	J421DD-9PL	421DDS-9A
M39016/28-022L	J421DD-12PL	421DDS-12A
M39016/28-023L	J421DD-18PL	421DDS-18A
M39016/28-024L	J421DD-26PL	421DDS-26A
M39016/28-025L	J421DD-5L	421DD-5A
M39016/28-026L	J421DD-6L	421DD-6A
M39016/28-027L	J421DD-9L	421DD-9A
M39016/28-028L	J421DD-12L	421DD-12A
M39016/28-029L	J421DD-18L	421DD-18A
M39016/28-030L	J421DD-26L	421DD-26A
NOTE: RELAYS INCLUDE ATTACHED SPREADER PADS.		
M39016/28-031L	J421DDM-5L	421DDM-5A
M39016/28-032L	J421DDM-6L	421DDM-6A
M39016/28-033L	J421DDM-9L	421DDM-9A
M39016/28-034L	J421DDM-12L	421DDM-12A
M39016/28-035L	J421DDM-18L	421DDM-18A
M39016/28-036L	J421DDM-26L	421DDM-26A
M39016/29-025L	J420D-6WL	
M39016/29-026L	J420D-9WL	
M39016/29-027L	J420D-12WL	
M39016/29-028L	J420D-18WL	
M39016/29-029L	J420D-26WL	
M39016/29-030L	J420D-5WL	
M39016/29-031L	J422D-5WL	
M39016/29-032L	J422D-6WL	
M39016/29-033L	J422D-9WL	
M39016/29-034L	J422D-12WL	
M39016/29-035L	J422D-18WL	
M39016/29-036L	J422D-26WL	
M39016/29-037L	J420D-6PL	420DS-6A
M39016/29-038L	J420D-9PL	420DS-9A
M39016/29-039L	J420D-12PL	420DS-12A
M39016/29-040L	J420D-18PL	420DS-18A
M39016/29-041L	J420D-26PL	420DS-26A
M39016/29-042L	J420D-5PL	420DS-5A
M39016/29-043L	J422D-5PL	422DS-5A
M39016/29-044L	J422D-6PL	422DS-6A
M39016/29-045L	J422D-9PL	422DS-9A
M39016/29-046L	J422D-12PL	422DS-12A
M39016/29-047L	J422D-18PL	422DS-18A
M39016/29-048L	J422D-26PL	422DS-26A
M39016/29-049L	J420D-6L	420D-6A
M39016/29-050L	J420D-9L	420D-9A
M39016/29-051L	J420D-12L	420D-12A
M39016/29-052L	J420D-18L	420D-18A
M39016/29-053L	J420D-26L	420D-26A
M39016/29-054L	J420D-5L	420D-5A
M39016/29-055L	J422D-5L	422D-5A
M39016/29-056L	J422D-6L	422D-6A
M39016/29-057L	J422D-9L	422D-9A
M39016/29-058L	J422D-12L	422D-12A

GOVERNMENT DESIGNATION	TELEDYNE DESIGNATION	COMPARABLE TELEDYNE T ² R™ (Reference Only)
M39016/29-059L	J422D-18L	422D-18A
M39016/29-060L	J422D-26L	422D-26A
M39016/29-073L	J422DX-12L	422DX-12A
M39016/29-074L	J422DX-5L	422DX-5A
M39016/29-075L	J422DX-6L	422DX-6A
M39016/29-076L	J422DX-9L	422DX-9A
M39016/29-077L	J422DX-18L	422DX-18A
M39016/29-078L	J422DX-26L	422DX-26A

NOTE: RELAYS INCLUDE ATTACHED SPREADER PADS.

M39016/29-061L	J420DM-6L	420DM-6A
M39016/29-062L	J420DM-9L	420DM-9A
M39016/29-063L	J420DM-12L	420DM-12A
M39016/29-064L	J420DM-18L	420DM-18A
M39016/29-065L	J420DM-26L	420DM-26A
M39016/29-066L	J420DM-5L	420DM-5A
M39016/29-067L	J422DM-5L	422DM-5A
M39016/29-068L	J422DM-6L	422DM-6A
M39016/29-069L	J422DM-9L	422DM-9A
M39016/29-070L	J422DM-12L	422DM-12A
M39016/29-071L	J422DM-18L	422DM-18A
M39016/29-072L	J422DM-26L	422DM-26A

M39016/30-025L	J420DD-6WL	
M39016/30-026L	J420DD-9WL	
M39016/30-027L	J420DD-12WL	
M39016/30-028L	J420DD-18WL	
M39016/30-029L	J420DD-26WL	
M39016/30-030L	J420DD-5WL	
M39016/30-031L	J422DD-5WL	
M39016/30-032L	J422DD-6WL	
M39016/30-033L	J422DD-9WL	
M39016/30-034L	J422DD-12WL	
M39016/30-035L	J422DD-18WL	
M39016/30-036L	J422DD-26WL	
M39016/30-037L	J420DD-6PL	420DDS-6A
M39016/30-038L	J420DD-9PL	420DDS-9A
M39016/30-039L	J420DD-12PL	420DDS-12A
M39016/30-040L	J420DD-18PL	420DDS-18A
M39016/30-041L	J420DD-26PL	420DDS-26A
M39016/30-042L	J420DD-5PL	420DDS-5A
M39016/30-043L	J422DD-5PL	422DDS-5A
M39016/30-044L	J422DD-6PL	422DDS-6A
M39016/30-045L	J422DD-9PL	422DDS-9A
M39016/30-046L	J422DD-12PL	422DDS-12A
M39016/30-047L	J422DD-18PL	422DDS-18A
M39016/30-048L	J422DD-26PL	422DDS-26A
M39016/30-049L	J420DD-6L	420DD-6A
M39016/30-050L	J420DD-9L	420DD-9A
M39016/30-051L	J420DD-12L	420DD-12A
M39016/30-052L	J420DD-18L	420DD-18A
M39016/30-053L	J420DD-26L	420DD-26A
M39016/30-054L	J420DD-5L	420DD-5A
M39016/30-055L	J422DD-5L	422DD-5A
M39016/30-056L	J422DD-6L	422DD-6A
M39016/30-057L	J422DD-9L	422DD-9A
M39016/30-058L	J422DD-12L	422DD-12A
M39016/30-059L	J422DD-18L	422DD-18A
M39016/30-060L	J422DD-26L	422DD-26A
M39016/30-073L	J422DDX-12L	422DDX-12A
M39016/30-074L	J422DDX-5L	422DDX-5A
M39016/30-075L	J422DDX-6L	422DDX-6A
M39016/30-076L	J422DDX-9L	422DDX-9A
M39016/30-077L	J422DDX-18L	422DDX-18A
M39016/30-078L	J422DDX-26L	422DDX-26A

NOTE: RELAYS INCLUDE ATTACHED SPREADER PADS.

M39016/30-061L	J420DDM-6L	420DDM-6A
M39016/30-062L	J420DDM-9L	420DDM-9A
M39016/30-063L	J420DDM-12L	420DDM-12A
M39016/30-064L	J420DDM-18L	420DDM-18A
M39016/30-065L	J420DDM-26L	420DDM-26A
M39016/30-066L	J420DDM-5L	420DDM-5A
M39016/30-067L	J422DDM-5L	422DDM-5A
M39016/30-068L	J422DDM-6L	422DDM-6A
M39016/30-069L	J422DDM-9L	422DDM-9A
M39016/30-070L	J422DDM-12L	422DDM-12A

GOVERNMENT DESIGNATION	TELEDYNE DESIGNATION	COMPARABLE TELEDYNE T ² R™ (Reference Only)
M39016/30-071L	J422DDM-18L	422DDM-18A
M39016/30-072L	J422DDM-26L	422DDM-26A
M39016/41-033L	J134-5L	134-5A
M39016/41-034L	J134-6L	134-6A
M39016/41-035L	J134-12L	134-12A
M39016/41-036L	J134-26L	134-26A
M39016/41-037L	J134-36L	134-36A
M39016/41-038L	J134-48L	134-48A
M39016/41-039L	J134-9L	134-9A
M39016/41-040L	J134-18L	134-18A
M39016/41-041L	J134-5PL	134S-5A
M39016/41-042L	J134-6PL	134S-6A
M39016/41-043L	J134-12PL	134S-12A
M39016/41-044L	J134-26PL	134S-26A
M39016/41-045L	J134-36PL	134S-36A
M39016/41-046L	J134-48PL	134S-48A
M39016/41-047L	J134-9PL	134S-9A
M39016/41-048L	J134-18PL	134S-18A
M39016/41-057L	J134Z-5L	134Z-5A
M39016/41-058L	J134Z-6L	134Z-6A
M39016/41-059L	J134Z-12L	134Z-12A
M39016/41-060L	J134Z-26L	134Z-26A
M39016/41-061L	J134Z-36L	134Z-36A
M39016/41-062L	J134Z-48L	134Z-48A
M39016/41-063L	J134Z-9L	134Z-9A
M39016/41-064L	J134Z-18L	134Z-18A

NOTE: RELAYS INCLUDE ATTACHED SPACER PADS.

M39016/41-049L	J134M4-5L	134M4-5A
M39016/41-050L	J134M4-6L	134M4-6A
M39016/41-051L	J134M4-12L	134M4-12A
M39016/41-052L	J134M4-26L	134M4-26A
M39016/41-053L	J134M4-36L	134M4-36A
M39016/41-054L	J134M4-48L	134M4-48A
M39016/41-055L	J134M4-9L	134M4-9A
M39016/41-056L	J134M4-18L	134M4-18A
M39016/41-065L	J134ZM4-5L	134ZM4-5A
M39016/41-066L	J134ZM4-6L	134ZM4-6A
M39016/41-067L	J134ZM4-12L	134ZM4-12A
M39016/41-068L	J134ZM4-26L	134ZM4-26A
M39016/41-069L	J134ZM4-36L	134ZM4-36A
M39016/41-070L	J134ZM4-48L	134ZM4-48A
M39016/41-071L	J134ZM4-9L	134ZM4-9A
M39016/41-072L	J134ZM4-18L	134ZM4-18A

M39016/42-033L	J134D-5L	134D-5A
M39016/42-034L	J134D-6L	134D-6A
M39016/42-035L	J134D-12L	134D-12A
M39016/42-036L	J134D-26L	134D-26A
M39016/42-037L	J134D-36L	134D-36A
M39016/42-038L	J134D-48L	134D-48A
M39016/42-039L	J134D-9L	134D-9A
M39016/42-040L	J134D-18L	134D-18A
M39016/42-041L	J134D-5PL	134DS-5A
M39016/42-042L	J134D-6PL	134DS-6A
M39016/42-043L	J134D-12PL	134DS-12A
M39016/42-044L	J134D-26PL	134DS-26A
M39016/42-045L	J134D-36PL	134DS-36A
M39016/42-046L	J134D-48PL	134DS-48A
M39016/42-047L	J134D-9PL	134DS-9A
M39016/42-048L	J134D-18PL	134DS-18A
M39016/42-057L	J134DZ-5L	134DZ-5A
M39016/42-058L	J134DZ-6L	134DZ-6A
M39016/42-059L	J134DZ-12L	134DZ-12A
M39016/42-060L	J134DZ-26L	134DZ-26A
M39016/42-061L	J134DZ-36L	134DZ-36A
M39016/42-062L	J134DZ-48L	134DZ-48A
M39016/42-063L	J134DZ-9L	134DZ-9A
M39016/42-064L	J134DZ-18L	134DZ-18A

NOTE: RELAYS INCLUDE ATTACHED SPACER PADS.

M39016/42-049L	J134DM4-5L	134DM4-5A
M39016/42-050L	J134DM4-6L	134DM4-6A
M39016/42-051L	J134DM4-12L	134DM4-12A
M39016/42-052L	J134DM4-26L	134DM4-26A
M39016/42-053L	J134DM4-36L	134DM4-36A

GOVERNMENT DESIGNATION	TELEDYNE DESIGNATION	COMPARABLE TELEDYNE T ² R™ (Reference Only)
M39016/42-054L	J134DM4-48L	134DM4-48A
M39016/42-055L	J134DM4-9L	134DM4-9A
M39016/42-056L	J134DM4-18L	134DM4-18A
M39016/42-065L	J134DZM4-5L	134DZM4-5A
M39016/42-066L	J134DZM4-6L	134DZM4-6A
M39016/42-067L	J134DZM4-12L	134DZM4-12A
M39016/42-068L	J134DZM4-26L	134DZM4-26A
M39016/42-069L	J134DZM4-36L	134DZM4-36A
M39016/42-070L	J134DZM4-48L	134DZM4-48A
M39016/42-071L	J134DZM4-9L	134DZM4-9A
M39016/42-072L	J134DZM4-18L	134DZM4-18A

M39016/43-033L	J134DD-5L	134DD-5A
M39016/43-034L	J134DD-6L	134DD-6A
M39016/43-035L	J134DD-9L	134DD-9A
M39016/43-036L	J134DD-12L	134DD-12A
M39016/43-037L	J134DD-18L	134DD-18A
M39016/43-038L	J134DD-26L	134DD-26A
M39016/43-039L	J134DD-36L	134DD-36A
M39016/43-040L	J134DD-48L	134DD-48A
M39016/43-041L	J134DD-5PL	134DDS-5A
M39016/43-042L	J134DD-6PL	134DDS-6A
M39016/43-043L	J134DD-9PL	134DDS-9A
M39016/43-044L	J134DD-12PL	134DDS-12A
M39016/43-045L	J134DD-18PL	134DDS-18A
M39016/43-046L	J134DD-26PL	134DDS-26A
M39016/43-047L	J134DD-36PL	134DDS-36A
M39016/43-048L	J134DD-48PL	134DDS-48A
M39016/43-057L	J134DDZ-5L	134DDZ-5A
M39016/43-058L	J134DDZ-6L	134DDZ-6A
M39016/43-059L	J134DDZ-9L	134DDZ-9A
M39016/43-060L	J134DDZ-12L	134DDZ-12A
M39016/43-061L	J134DDZ-18L	134DDZ-18A
M39016/43-062L	J134DDZ-26L	134DDZ-26A
M39016/43-063L	J134DDZ-36L	134DDZ-36A
M39016/43-064L	J134DDZ-48L	134DDZ-48A

NOTE: RELAYS INCLUDE ATTACHED SPACER PADS.

M39016/43-049L	J134DDM4-5L	134DDM4-5A
M39016/43-050L	J134DDM4-6L	134DDM4-6A
M39016/43-051L	J134DDM4-9L	134DDM4-9A
M39016/43-052L	J134DDM4-12L	134DDM4-12A
M39016/43-053L	J134DDM4-18L	134DDM4-18A
M39016/43-054L	J134DDM4-26L	134DDM4-26A
M39016/43-055L	J134DDM4-36L	134DDM4-36A
M39016/43-056L	J134DDM4-48L	134DDM4-48A
M39016/43-065L	J134DDZM4-5L	134DDZM4-5A
M39016/43-066L	J134DDZM4-6L	134DDZM4-6A
M39016/43-067L	J134DDZM4-9L	134DDZM4-9A
M39016/43-068L	J134DDZM4-12L	134DDZM4-12A
M39016/43-069L	J134DDZM4-18L	134DDZM4-18A
M39016/43-070L	J134DDZM4-26L	134DDZM4-26A
M39016/43-071L	J134DDZM4-36L	134DDZM4-36A
M39016/43-072L	J134DDZM4-48L	134DDZM4-48A

SECTION III

Commercial/Industrial Centigrad® and TO-5 Relays

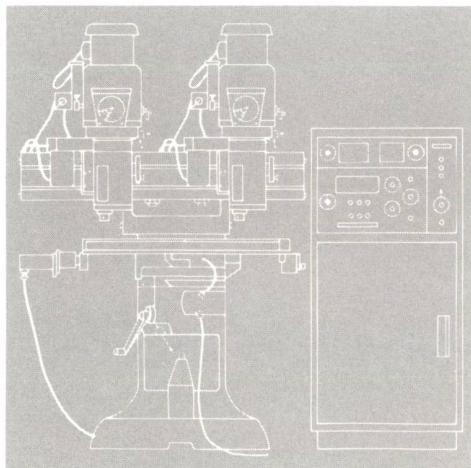
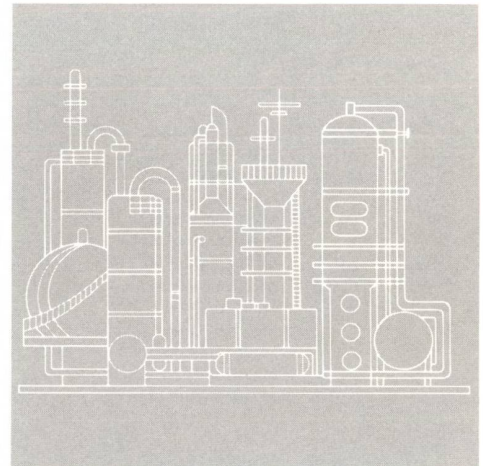
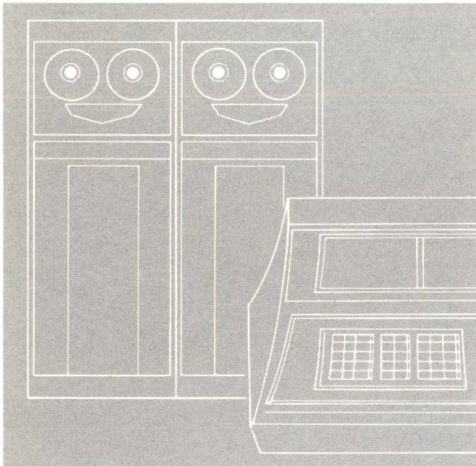
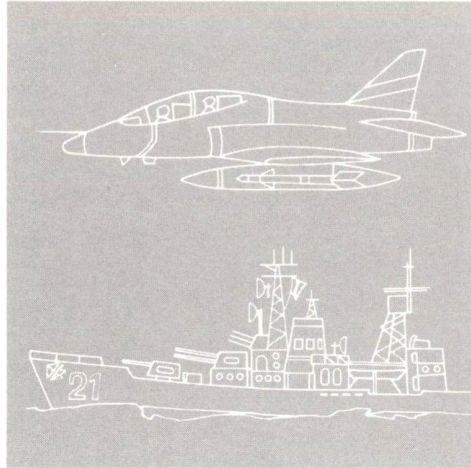

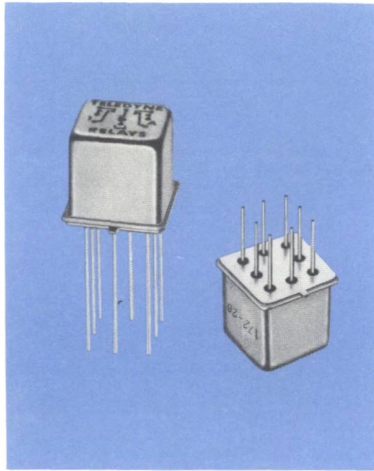

TELEDYNE RELAYS

CENTIGRID® COMMERCIAL RELAY

DPDT

SERIES
172

SERIES DESIGNATION	RELAY TYPE
172	DPDT basic relay
172D	DPDT relay with internal diode for coil transient suppression

INTERNAL CONSTRUCTION

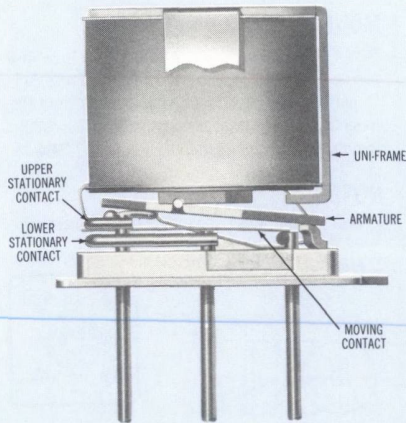

DESCRIPTION

The 172 Centigrad® relay is an ultraminiature, hermetically sealed, armature relay for commercial applications. Its low profile height (0.380") and .100" grid spaced terminals, which precludes the need for spreader pads, makes it an ideal choice where extreme packaging density and/or close PC board spacing are required.

The basic concept and internal structure are similar to the Teledyne DPDT Centigrad® relay (114 Series). Unique construction features and manufacturing techniques provide overall high reliability and excellent resistance to environmental extremes:

- All welded construction.
- Unique uni-frame design providing high magnetic efficiency and mechanical rigidity.
- High force/mass ratios to withstand shock and vibration.
- Advanced cleaning and sealing techniques provide maximum assurance of internal cleanliness.
- Precious metal alloy contact material with gold plating assures excellent high current and dry circuit switching capabilities.

The 172D Series utilizes an internal discrete silicon diode for coil suppression with electrical characteristics as specified herein.

By virtue of its inherently low intercontact capacitance and contact circuit losses, the 172 relay is an excellent subminiature RF switch for frequency ranges well into the UHF spectrum (see Figure 1). Applications include telecommunications, test instruments, mobile communications, attenuators, and automatic test equipment.

ENVIRONMENTAL AND PHYSICAL SPECIFICATIONS

Temperature (Ambient)	-55°C to +85°C
Vibration	10 g's to 500 Hz (Note 3)
Shock	30 g's for 6 msec. (Note 3) half-sine
Enclosure	All welded, hermetically sealed
Weight	0.15 oz. (4.3 gms.) max.

SERIES 172

GENERAL ELECTRICAL SPECIFICATIONS (@ 25°C) (NOTES 1 AND 2)

Contact Arrangement	2 Form C (DPDT)	
Rated Duty	Continuous	
Contact Resistance (Note 4)	0.15 ohm max. before life; 0.3 ohm max. after life at 1A/28VDC, (measured 1/8" from header)	
Contact Load Rating (DC) (See Fig. 2 for other DC resistive voltage/current ratings)	Resistive: 1 Amp/28VDC Inductive: 200 mA/28VDC (320 mH) Lamp: 100 mA/28VDC Low Level: 10 to 50 μ A / 10 to 50 mV	
Contact Life Ratings	5,000,000 cycles (typical) at low level 500,000 cycles (typical) at 0.5A/28VDC resistive 100,000 cycles min. at all other loads specified above	
Contact Overload Rating	2 A/28VDC Resistive (100 cycles min.)	
Contact Carry Rating	Contact factory	
Operate Time	6.0 msec. max. at nominal rated coil voltage	
Release Time	172: 3.0 msec. max.	172D: 6.0 msec. max.
Intercontact Capacitance	0.4 pf. typical	
Insulation Resistance	1,000 megohms min. between mutually isolated terminals	
Dielectric Strength	Sea level: 300 VRMS/60 Hz	
Diode P.I.V. 172D	60 VDC, Min.	
Negative Coil Transient 172D	2.0 VDC, Max.	

DETAILED ELECTRICAL SPECIFICATIONS (@ 25°C) (NOTE 2)

	GENERIC PART NUMBERS	172-5 172D-5	172-12 172D-12	172-26 172D-26
Coil Voltage (VDC)	Nom.	5.0	12.0	26.5
	Max.	5.8	16.0	32.0
Coil Resistance (ohms \pm 20%)		64	400	1600
Pick-up Voltage (VDC, Max.) Pulse Operation		3.8	9.0	18.0
Coil Operating Power at Nominal Voltage (Milliwatts)		390	360	440

OUTLINE DIMENSIONS

CASE DETAIL

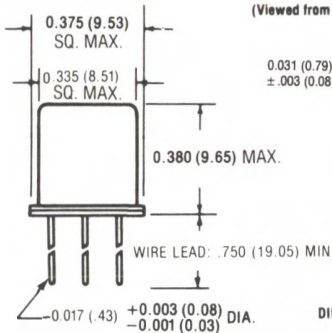

TERMINAL LOCATIONS

(Viewed from Terminals, Numbers for Reference only)

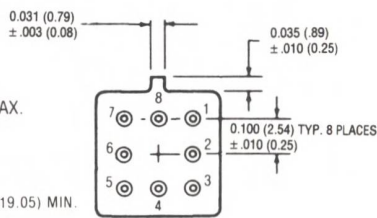

DIMENSIONS ARE SHOWN IN INCHES (MILLIMETERS)

SCHEMATIC DIAGRAM

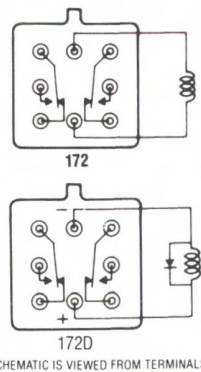

SCHEMATIC IS VIEWED FROM TERMINALS

MOUNTING PAD

Relays can be supplied with a .014 in. thick mounting pad cemented to the relay header. The pad (P/N 194-3) permits the relay to be spaced away from the mounting surface facilitating solder joint inspection. To order add M4 to Part Number. Example: 172M4-26.

NOTES:

1. Max. height above mounting surface increased by 0.025 in. (0.64mm).
2. Material: Polyester Film.

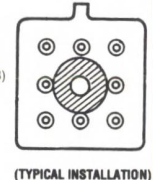
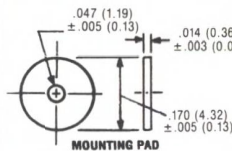

PERFORMANCE CURVES (NOTE 1)

TYPICAL RF PERFORMANCE

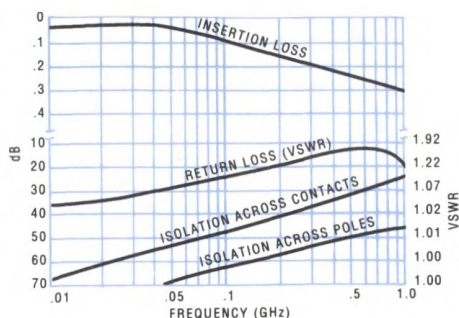

FIGURE 1

TYPICAL DC CONTACT RATINGS (RESISTIVE)

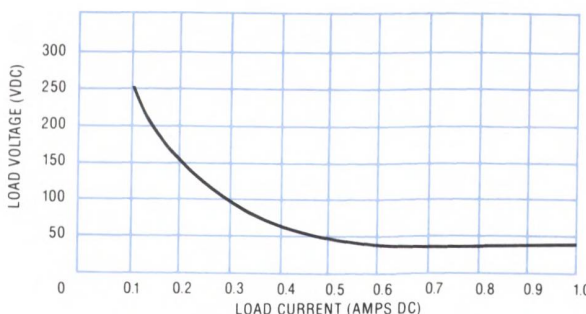

FIGURE 2

NOTES

1. Characteristics shown as typical are based upon available data and are best estimates. No on-going verification tests are performed.
2. Characteristics are subject to change after life.
3. Contact will exhibit no chatter in excess of 10 μ sec or transfer in excess of 1 μ sec.
4. Add 0.01 ohm to contact resistance with mounting pad.

TELEDYNE RELAYS

**SERIES
S172**

CENTIGRID® SURFACE MOUNT COMMERCIAL RELAY DPDT

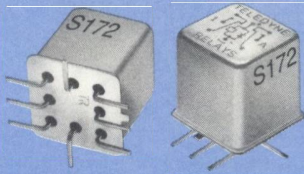

SERIES DESIGNATION	RELAY TYPE
S172	DPDT basic relay
S172D	DPDT relay with internal diode for coil transient suppression

INTERNAL CONSTRUCTION

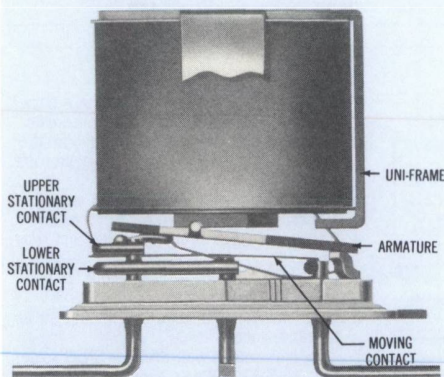

DESCRIPTION

The S172 Surface Mount Centigrad® relay is an ultraminiature, hermetically sealed, armature relay for commercial applications. Its low profile height (.470) and .100" grid spaced terminals, which precludes the need for spreader pads, makes it an ideal choice where extreme packaging density and/or close PC board spacing are required. The specially formed leads are pre-tinned to make the relays ideal for all types of surface mount solder reflow processes.

The basic design and internal structure are similar to the Teledyne DPDT Centigrad® relay (114 Series). Unique construction features and manufacturing techniques provide overall high reliability and excellent resistance to environmental extremes:

- All-welded construction.
- Unique uni-frame design providing high magnetic efficiency and mechanical rigidity.
- High force/mass ratios to withstand shock and vibration.
- Advanced cleaning and sealing techniques provide maximum assurance of internal cleanliness.
- Precious metal alloy contact material with gold plating assures excellent high current and dry circuit switching capabilities.

The S172D Series utilizes an internal discrete silicon diode for coil suppression with electrical characteristics as specified herein.

By virtue of its inherently low intercontact capacitance and contact circuit losses, the S172 relay is an excellent subminiature RF switch for frequency ranges well into the UHF spectrum (see Figure 1). Applications include telecommunications, test instruments, mobile communications, attenuators, and automatic test equipment.

ENVIRONMENTAL AND PHYSICAL SPECIFICATIONS

Temperature (Ambient)	-55°C to +85°C
Vibration	10 g's to 500 Hz (Note 3)
Shock	30 g's for 6 msec. (Note 3) half-sine
Enclosure	All welded, hermetically sealed
Weight	0.15 oz. (4.3 gms.) max.
Reflow Temperature	260°C max. temp. 5 min. max. above 180°C

SERIES S172

GENERAL ELECTRICAL SPECIFICATIONS (@ 25°C) (NOTES 1 AND 2)

Contact Arrangement	2 Form C (DPDT)	
Rated Duty	Continuous	
Contact Resistance	0.15 ohm max. before life; 0.3 ohm max. after life at 1A/28VDC, (measured 1/8" from header)	
Contact Load Rating (DC) (See Fig. 2 for other DC resistive voltage/current ratings)	Resistive: 1 Amp/28VDC Inductive: 200 mA/28VDC (320 mH) Lamp: 100 mA/28VDC Low Level: 10 to 50 μ A/10 to 50 mV	
Contact Life Ratings	5,000,000 cycles (typical) at low level 500,000 cycles (typical) at 0.5A/28VDC resistive 100,000 cycles min. at all other loads specified above	
Contact Overload Rating	2 A/28VDC Resistive (100 cycles min.)	
Contact Carry Rating	Contact factory	
Operate Time	6.0 msec. max. at nominal rated coil voltage	
Release Time	S172: 3.0 msec. max.	S172D: 6.0 msec. max.
Intercontact Capacitance	0.4 pf. typical	
Insulation Resistance	1,000 megohms min. between mutually isolated terminals	
Dielectric Strength	Sea level: 300 VRMS/60 Hz	
Diode P.I.V. S172D	60 VDC, Min.	
Negative Coil Transient S172D	2.0 Volt, Max.	

DETAILED ELECTRICAL SPECIFICATIONS (@ 25°C) (NOTE 2)

	GENERIC PART NUMBERS	S172-5 S172D-5	S172-12 S172D-12	S172-26 S172D-26
Coil Voltage (VDC)	Nom.	5.0	12.0	26.5
	Max.	5.8	16.0	32.0
Coil Resistance (ohms \pm 20%)		64	400	1600
Pick-up Voltage (VDC, Max.) Pulse Operation		3.8	9.0	18.0
Coil Operating Power at Nominal Voltage (Milliwatts)		405	360	440

PERFORMANCE CURVES (NOTE 1)

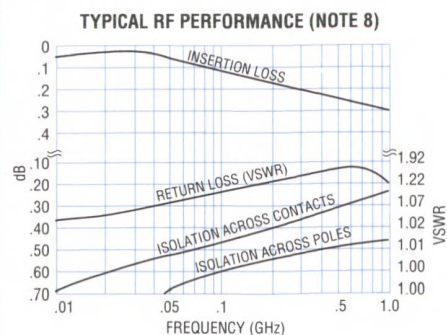

FIGURE 1

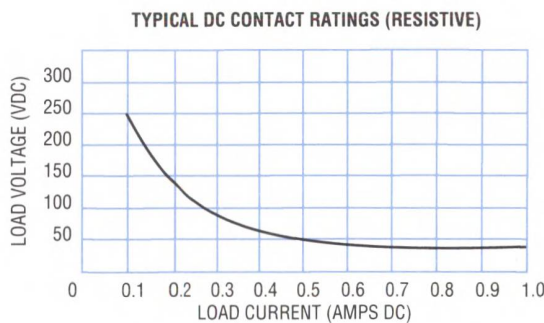
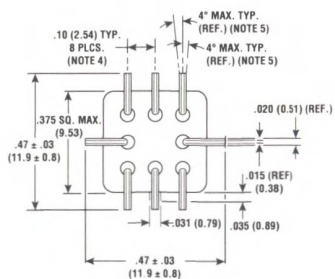
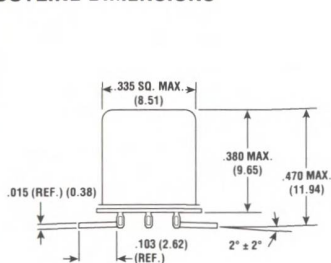

FIGURE 2

NOTES:

1. Characteristics shown as typical are based upon available data and are best estimates.
2. Characteristics are subject to change after life. No ongoing verification tests are performed.
3. Contact will exhibit no chatter in excess of 10 μ sec or transfer in excess of 1 μ sec.
4. Position of leads as they emerge from relay base.
5. Leads will fit noted pad layout with no overhang.
6. Lead ends are coplanar within .008" wide tolerance zone.
7. Terminals coated with SN60 or SN63 solder per QQ-S-571. Kovar exposed at sheared end of leads.
8. RF curves based on 172 Series.

OUTLINE DIMENSIONS



ALL DIMENSIONS ARE IN INCHES (MILLIMETERS)

RECOMMENDED PAD LAYOUT (NOTE 5)

TERMINAL LOCATIONS AND SCHEMATIC DIAGRAMS

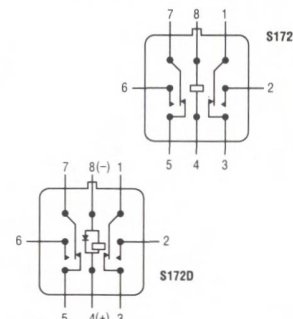

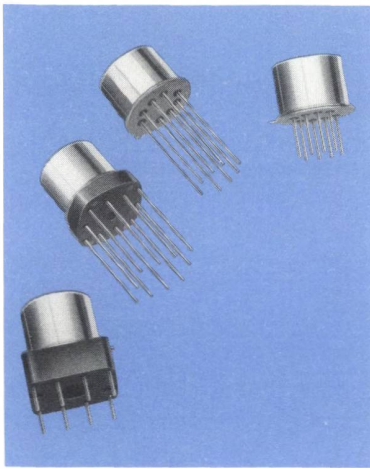

TELEDYNE RELAYS

COMMERCIAL/INDUSTRIAL TO-5 RELAYS

DPDT

SERIES
712

SERIES DESIGNATION	RELAY TYPE
712	DPDT basic relay
712D	DPDT relay with internal diode for coil transient suppression
712TN	DPDT relay with internal transistor driver and coil transient suppression diode

INTERNAL CONSTRUCTION

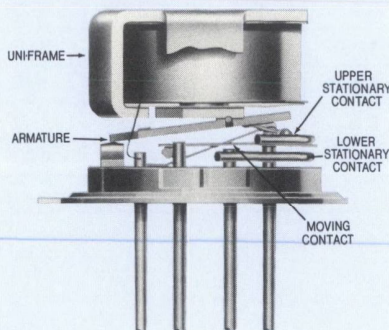

DESCRIPTION

The TO-5 relay, originally conceived and developed by Teledyne, has become the industry standard for low level switching from dry circuit to 1 ampere. Designed expressly for high density PC Board mounting, its small size and low coil power dissipation make the TO-5 relay the most versatile subminiature relay available.

Unique construction features and manufacturing techniques provide excellent resistance to environmental extremes and overall high reliability.

- All welded construction.
- Unique uni-frame design providing high magnetic efficiency and mechanical rigidity.
- High force/mass ratios for resistance to shock and vibration.
- Advanced cleaning and sealing techniques provide maximum assurance of internal cleanliness.
- Precious metal alloy contact material with gold plating assures excellent high current and dry circuit switching capabilities.

The 712D Series utilizes internal discrete silicon diodes, with characteristics similar to 1N5315. The hybrid 712TN Series features a silicon diode and transistor chip (similar to 2N2222A). The integrated packaging of the relay with its associated semiconductor devices greatly reduces PC Board floor space requirements as well as component installation costs.

By virtue of its inherently low intercontact capacitance and contact circuit losses, the TO-5 relay has proven to be an excellent subminiature RF switch for frequency ranges well into the UHF spectrum. A typical RF application for the TO-5 relay is in hand held radio transceivers, wherein the combined features of good RF performance, small size, low coil power dissipation and high reliability make it the preferred relay for Transmit-Receive switching (see Figure 1).

ENVIRONMENTAL AND PHYSICAL SPECIFICATIONS

Temperature (Ambient)	-55°C to +85°C
Vibration	10 g's to 500 Hz (Note 3)
Shock	30 g's for 6 msec. (Note 3) half-sine
Enclosure	All welded, hermetically sealed
Weight	0.09 oz. (2.6 gms.) max.

SERIES 712

GENERAL ELECTRICAL SPECIFICATIONS (@ 25°C) (NOTES 1 AND 2)

Contact Arrangement	2 Form C (DPDT)	
Rated Duty	Continuous	
Contact Resistance (Note 4)	0.15 ohm max. before life; 0.25 ohm max. after life at 1A/28VDC, (measured 1/8" from header)	
Contact Load Rating (DC) (See Fig. 2 for other DC resistive voltage/current ratings)	Resistive: 1 Amp/28VDC Inductive: 200 mA/28VDC (320 mH) Lamp: 100 mA/28VDC Low Level: 10 to 50 μ A/10 to 50 mV	
Contact Load Ratings (AC)	Resistive: 250 mA/115VAC, 60 and 400 Hz (Case not grounded) 100 mA/115VAC, 60 and 400 Hz, (Case grounded)	
Contact Life Ratings	10,000,000 cycles (typical) at low level 1,000,000 cycles (typical) at 0.5A/28VDC resistive 100,000 cycles min. at all other loads specified above	
Contact Overload Rating	2 A/28VDC Resistive (100 cycles min.)	
Contact Carry Rating	Contact factory	
Coil Operating Power	450 milliwatts typical at nominal rated voltage	
Operate Time	4.0 msec. max. at nominal rated coil voltage (712TN Series: see Note 6)	
Release Time	712 Series: 3.0 msec. max.	712D, 712TN Series: 6.0 msec. max.
Intercontact Capacitance	0.4 pf. typical	
Insulation Resistance	1,000 megohms min. between mutually isolated terminals	
Dielectric Strength	Sea level: 350 VRMS/60 Hz	
Diode P.I.V. (VDC) 712D, 712TN	60 min.	
Negative Coil Transient (VDC) 712D, 712TN	2.0 max.	
712TN Transistor Characteristics	Base Voltage to Turn Off (VDC)	0.3 min.
	Emitter-base breakdown Voltage (BV_{EB0}) (VDC)	6.0 min.
	Collector-base breakdown Voltage (BV_{CB0}) (@ 25°C & I_c = 100 μA) (VDC)	60 min.

DETAILED ELECTRICAL SPECIFICATIONS (@ 25°C) (NOTE 2)

	GENERIC PART NUMBERS	712-5 712D-5 712TN-5	712-6 712D-6 712TN-6	712-9 712D-9 712TN-9	712-12 712D-12 712TN-12	712-18 712D-18 712TN-18	712-26 712D-26 712TN-26
Coil Voltage (VDC)	Nom.	5.0	6.0	9.0	12.0	18.0	26.5
	Max.	5.8	8.0	12.0	16.0	24.0	32.0
Coil Resistance (Ohms \pm 10% @ 25°C) (Note 4)		50	98	220	390	880	1560
Pick-up Voltage (VDC, Max.) Pulse Operated (712TN SERIES — See Note 6)		3.6	4.2	6.5	8.4	13.0	17.0
Base Current to Turn On (mADC, Min.) (Note 6)		3.00	2.04	1.36	1.03	0.68	0.50

PERFORMANCE CURVES (NOTE 1)

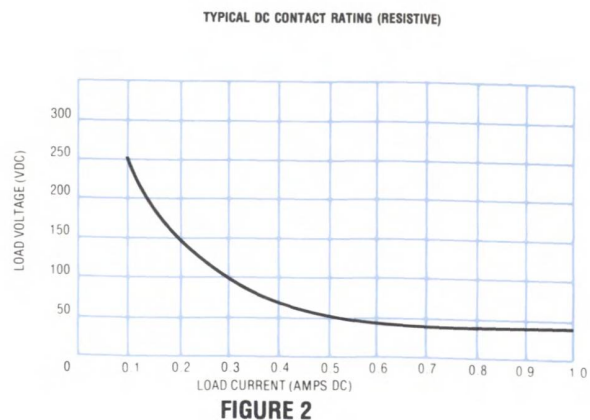
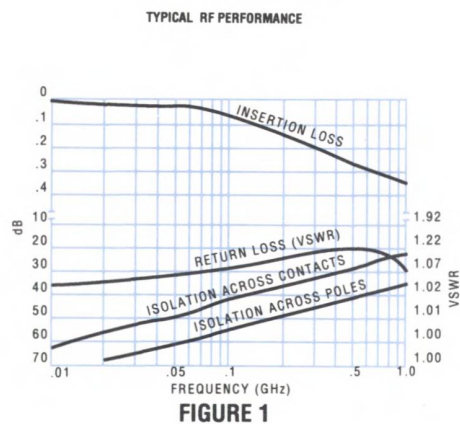

OUTLINE DIMENSIONS

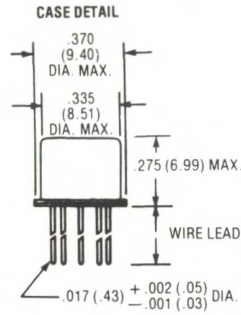

TERMINAL LOCATIONS AND PIN NUMBERING (REF. ONLY)
(Viewed from Terminals)

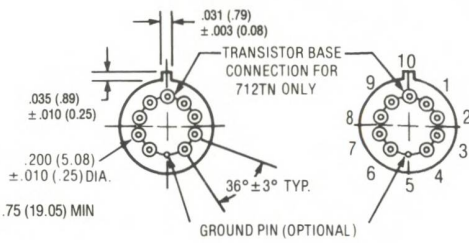

DIMENSIONS ARE SHOWN IN INCHES (MILLIMETERS)

SCHEMATIC DIAGRAMS

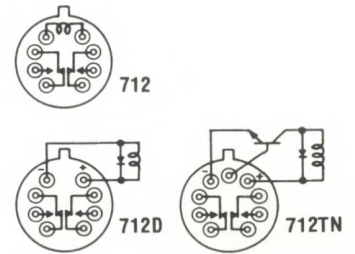

SCHEMATICS ARE VIEWED FROM TERMINALS

SPREADER PADS

Relays can be supplied with spreader pads installed and cemented in place. P/N 192-10 can be used with all 712, 712D, and 712TN Series Relays; P/N 192-59 is limited to 8 pins and therefore will not accommodate the 712TN Series Relay. Relays supplied with the 192-59 pad installed have leads trimmed to .130 in. (3.3mm) ± .010 (.25mm) below pad. To order, add M for the 192-10 pad or M2 for the 192-59 pad to the part number (e.g., 712DM2-26).

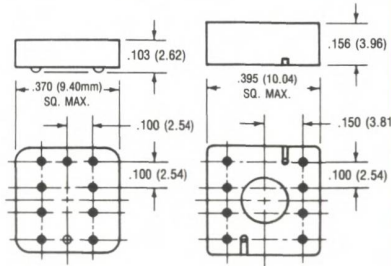

P/N192-10

P/N192-59

NOTES:

1. Material; Dialyl Phthalate.
2. Add .025 ohm to contact resistance with 192-10 pad; .05 ohm with 192-59 pad.

3. Leads exit from holes indicated.
4. Tolerance: .XXX ± .010 (0.26).

TYPICAL TTL INTERFACE CIRCUIT
(See Note 5)

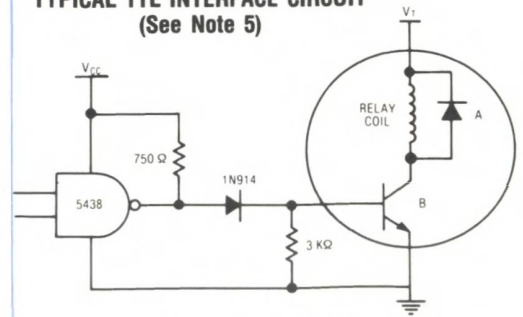

(A) INTERNAL SUPPRESSION DIODE (B) INTERNAL DRIVER TRANSISTOR

NOTES

1. Characteristics shown as "typical" are based on available data and are best estimates. No on-going verification tests are performed.
2. Characteristics are subject to change after life.
3. Relays will exhibit no contact chatter in excess of 10 μsec or transfer in excess of 1 μsec.
4. For Reference Only. Coil Resistance not directly measurable on 712TN Relays.
5. Circuit is typical for all 712TN Series. Values shown are for 712TN-5 relay, and apply over full operating temperature range.
6. Limit base-emitter current to 15 mADC.

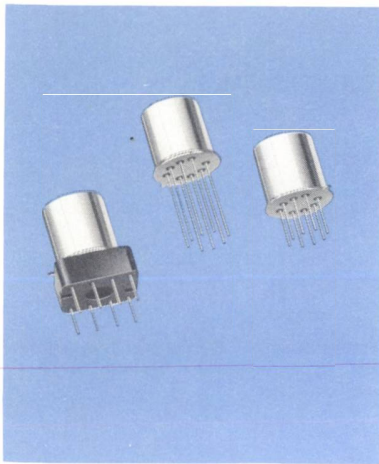

TELEDYNE RELAYS

COMMERCIAL/INDUSTRIAL SENSITIVE TO-5 RELAYS

DPDT

SERIES
732

SERIES DESIGNATION	RELAY TYPE
732	DPDT basic relay
732D	DPDT relay with internal diode for coil transient suppression
732TN	DPDT relay with internal transistor driver and coil transient suppression diode

INTERNAL CONSTRUCTION

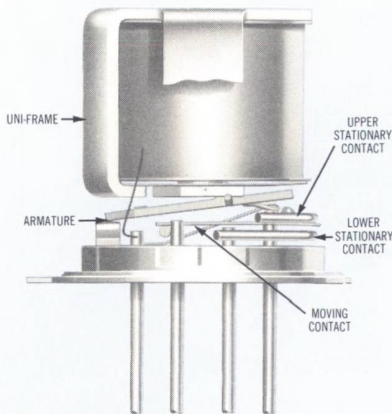

DESCRIPTION

The TO-5 relay, originally conceived and developed by Teledyne, has become the industry standard for low level switching from dry circuit to 1 ampere. Designed expressly for high density PC Board mounting, its small size and low coil power dissipation make the TO-5 relay the most versatile subminiature relay available.

Unique construction features and manufacturing techniques provide excellent resistance to environmental extremes and overall high reliability.

- All welded construction.
- Unique uni-frame design providing high magnetic efficiency and mechanical rigidity.
- High force/mass ratios for resistance to shock and vibration.
- Advanced cleaning and sealing techniques provide maximum assurance of internal cleanliness.
- Precious metal alloy contact material with gold plating assures excellent high current and dry circuit switching capabilities.

The 732D relay utilizes internal discrete silicon diodes, with characteristics similar to 1N5315. The hybrid 732TN Series features a silicon diode and transistor chip (similar to 2N2222A). The integrated packaging of the relay with its associated semiconductor devices greatly reduces PC Board floor space requirements as well as component installation costs.

By virtue of its inherently low intercontact capacitance and contact circuit losses, the TO-5 relay has proven to be an excellent subminiature RF switch for frequency ranges well into the UHF spectrum. A typical RF application for the TO-5 relay is in hand held radio transceivers, wherein the combined features of good RF performance, small size, low coil power dissipation and high reliability make it the preferred relay for Transmit-Receive switching (see Figure 1).

ENVIRONMENTAL AND PHYSICAL SPECIFICATIONS

Temperature (Ambient)	-55°C to +85°C
Vibration	10 g's to 500 Hz (Note 3)
Shock	30 g's for 6 msec. (Note 3) half-sine
Enclosure	All welded, hermetically sealed
Weight	0.16 oz. (4.50 gms.) max.

GENERAL ELECTRICAL SPECIFICATIONS (@ 25°C) (NOTES 1 AND 2)

Contact Arrangement	2 Form C (DPDT)	
Rated Duty	Continuous	
Contact Resistance	0.15 ohm max. before life; 0.25 ohm max. after life at 1A/28VDC, (measured 1/8" from header)	
Contact Load Rating (DC) (See Fig. 2 for other DC resistive voltage/current ratings)	Resistive: 1 Amp/28VDC Inductive: 200 mA/28VDC (320 mH) Lamp: 100 mA/28VDC Low Level: 10 to 50 μ A/10 to 50 mV	
Contact Load Ratings (AC)	Resistive: 250 mA/115VAC, 60 and 400 Hz (Case not grounded) 100 mA/115VAC, 60 and 400 Hz, (Case grounded)	
Contact Life Ratings	10,000,000 cycles (typical) at low level 1,000,000 cycles (typical) at 0.5A/28VDC resistive 100,000 cycles min. at all other loads specified above	
Contact Overload Rating	2 A/28VDC Resistive (100 cycles min.)	
Contact Carry Rating	Contact factory	
Coil Operating Power	200 milliwatts typical at nominal rated voltage	
Operate Time	6.0 msec. max. at nominal rated coil voltage (732TN Series: see Note 6)	
Release Time	732 Series: 3.0 msec. max.	732D, 732TN Series: 7.5 msec. max.
Intercontact Capacitance	0.4 pf. typical	
Insulation Resistance	1,000 megohms min. between mutually isolated terminals	
Dielectric Strength	Sea level: 350 VRMS/60 Hz	
Diode P.I.V. (VDC)	60 min.	
Negative Coil Transient (VDC) 732D, 732TN	2.0 max.	
732TN Transistor Characteristics	Base Voltage to Turn Off (VDC)	0.3 min.
	Emitter-base breakdown Voltage (BV_{EB0}) (VDC)	6.0 min.
	Collector-base breakdown Voltage (BV_{CB0}) (I_c = 100 μA) (VDC)	60 min.

DETAILED ELECTRICAL SPECIFICATIONS (@ 25°C) (NOTE 2)

	GENERIC PART NUMBERS	732-5 732D-5 732TN-5	732-6 732D-6 732TN-6	732-9 732D-9 732TN-9	732-12 732D-12 732TN-12	732-18 732D-18 732TN-18	732-26 732D-26 732TN-26
Coil Voltage (VDC)	Nom.	5.0	6.0	9.0	12.0	18.0	26.5
	Max.	7.5	10.0	15.0	20.0	30.0	40.0
Coil Resistance (Ohms \pm 10% @ 25°C) (Note 4)		100	200	400	850	1600	3300
Pick-up Voltage (VDC, Max.) Pulse Operated (732TN SERIES — See Note 6)		3.5	4.5	6.8	9.0	13.5	18.0
Base Current to Turn On (mADC, Min.) (Note 6)		1.50	1.00	0.75	0.47	0.38	0.24

PERFORMANCE CURVES (NOTE 1)

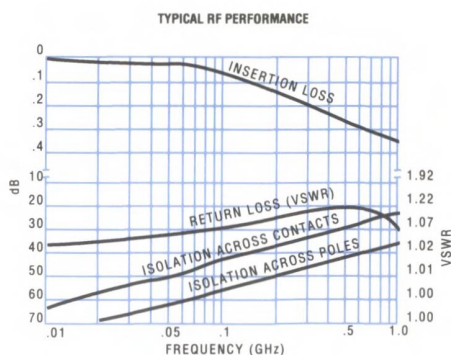

FIGURE 1

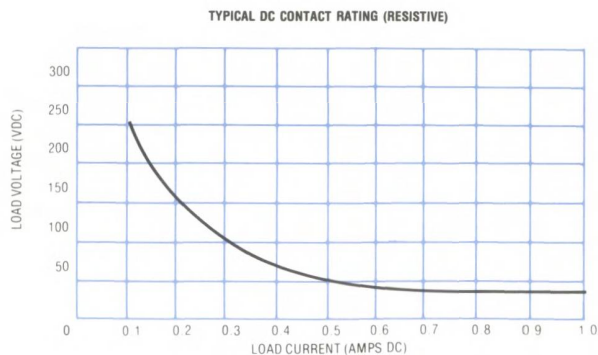
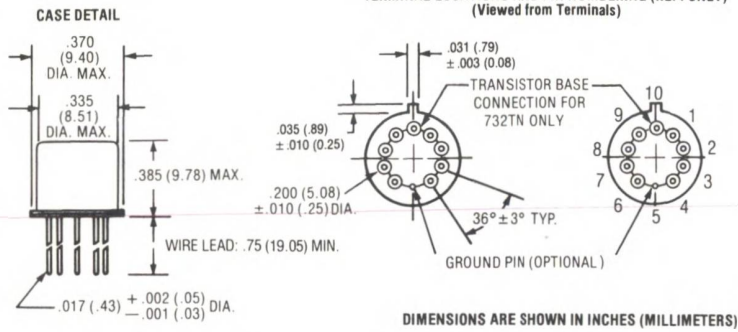

FIGURE 2

SERIES 732

OUTLINE DIMENSIONS



SCHEMATIC DIAGRAMS

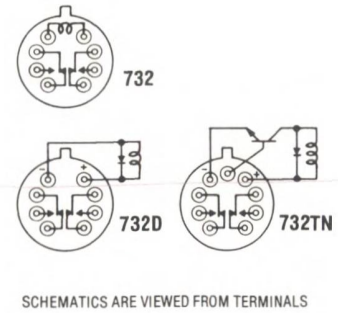

SPREADER PADS

Relays can be supplied with spreader pads installed and cemented in place. P/N 192-10 can be used with all 732, 732D, and 732TN Series Relays; P/N 192-59 is limited to 8 pins and therefore will not accommodate the 732TN Series Relay. Relays supplied with the 192-59 pad installed have leads trimmed to .130 in. (3.3mm) ± .010 (.25mm) below pad. To order, add M for the 192-10 pad or M2 for the 192-59 pad to the part number (e.g., 732DM2-26).

NOTES:

1. Material: Diallyl phthalate.
2. Add .025 ohm to contact resistance with 192-10 pad; .05 ohm with 192-59 pad.
3. Leads exit from holes indicated.
4. Tolerance: .XXX = ± .010 (0.26).

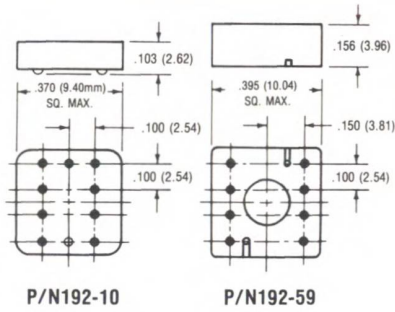

TYPICAL TTL INTERFACE CIRCUIT (See Note 5)

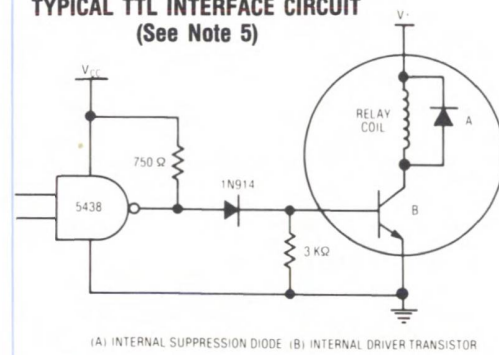

NOTES

1. Characteristics shown as "typical" are based on available data and are best estimates. No on-going verification tests are performed.
2. Characteristics are subject to change after life.
3. Relays will exhibit no contact chatter in excess of 10 μsec or transfer in excess of 1 μsec.
4. For Reference Only. Coil Resistance not directly measurable on 732TN relay.
5. Circuit is typical for all 732TN Series. Values shown are for 732TN-5 relay, and apply over full operating temperature range.
6. Limit base-emitter current to 15 mADC.

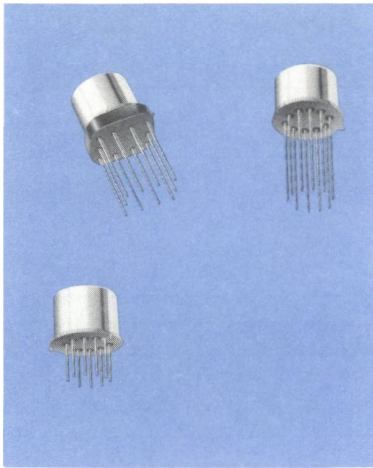

TELEDYNE RELAYS

SERIES
720/722

COMMERCIAL/INDUSTRIAL TO-5 RELAY DPDT MAGNETIC LATCHING

SERIES DESIGNATION	RELAY TYPE
720/722	DPDT relay
720D/722D	DPDT relay with internal diode for coil transient suppression

DESCRIPTION

The TO-5 relay, originally conceived and developed by Teledyne, has become the industry standard for low level switching from dry circuit to 1 ampere. Designed expressly for high density PC Board mounting, its small size and low coil power dissipation make the TO-5 relay the most versatile subminiature relay available.

Unique construction features and manufacturing techniques provide excellent resistance to environmental extremes and overall high reliability.

- All welded construction.
- Unique uni-frame design providing high magnetic efficiency and mechanical rigidity.
- High force/mass ratios for resistance to shock and vibration.
- Advanced cleaning and sealing techniques provide maximum assurance of internal cleanliness.
- Precious metal alloy contact material with gold plating assures excellent high current and dry circuit switching capabilities.

The 720D/722D Series utilize discrete silicon diodes with characteristics similar to 1H5315.

The 720/722 Series magnetic latching relays are ideally suited for applications where power dissipation must be minimized. The relays can be operated with a short duration pulse and after contacts have transferred, no holding power is required.

The magnetic latching feature of the 720/722 Series provides a "memory" capability, since the relays will not reset upon removal of power.

By virtue of its inherently low intercontact capacitance and contact circuit losses, the TO-5 relay has proven to be an excellent subminiature RF switch for frequency ranges well into the UHF spectrum. A typical RF application for the TO-5 relay is in hand held radio transceivers, wherein the combined features of good RF performance, small size, low coil power dissipation and high reliability make it the preferred relay for Transmit-Receive switching (see Figure 1).

PRINCIPLE OF OPERATION

Energizing Coil B produces a magnetic field opposing the holding flux of the permanent magnet in Circuit B. As this net holding force decreases, the attractive force in the air gap of Circuit A, which also results from the flux of the permanent magnet, becomes great enough to break the armature free of Core B, and snap it into a closed position against Core A. The armature then remains in this position upon removal of power from Coil B, but will snap back to position B upon energizing Coil A. Since operation depends upon cancellation of a magnetic field, it is necessary to apply the correct polarity to the relay coils as indicated on the relay schematic.

When latching relays are installed in equipment, the latch and reset coils should not be pulsed simultaneously. Coils should not be pulsed with less than the nominal coil voltage and the pulse width should be a minimum of three times the specified operate time of the relay. If these conditions are not followed, it is possible for the relay to be in the magnetically neutral position.

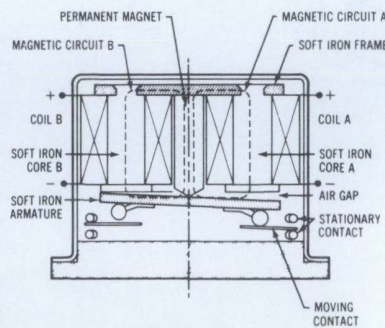

ENVIRONMENTAL AND PHYSICAL SPECIFICATIONS

Temperature (Ambient)	-55°C to +85°C
Vibration	10 g's to 1000 Hz (Note 3)
Shock	30 g's for 6 msec. (Note 3) half-sine
Enclosure	All welded, hermetically sealed
Weight	0.1 oz. (2.9 gms.) max.

SERIES 720/722

GENERAL ELECTRICAL SPECIFICATIONS (@ 25°C) (NOTES 1 AND 2)

Contact Arrangement	2 Form C (DPDT)
Rated Duty	Continuous
Contact Resistance	0.15 ohm max. before life; 0.25 ohm max. after life at 1A/28VDC, (measured 1/8" from header)
Contact Load Rating (DC) (See Fig. 2 for other DC resistive voltage/current ratings)	Resistive: 1 Amp/28VDC Inductive: 200 mA/28VDC (320 mH) Lamp: 100 mA/28VDC Low Level: 10 to 50 μ A/10 to 50 mV
Contact Load Ratings (AC)	Resistive: 250 mA/115VAC, 60 and 400 Hz (Case not grounded) 100 mA/115VAC, 60 and 400 Hz, (Case grounded)
Contact Life Ratings	10,000,000 cycles (typical) at low level 1,000,000 cycles (typical) at 0.5A/28VDC resistive 100,000 cycles min. at all other loads specified above
Contact Overload Rating	2 A/28VDC Resistive (100 cycles min.)
Contact Carry Rating	Contact factory
Coil Operating Power	290 milliwatts typical at nominal rated voltage
Operate Time	2.0 msec. max. at nominal rated coil voltage
Minimum Operate Pulse	6.0 msec. at nominal voltage
Intercontact Capacitance	0.4 pf. typical
Insulation Resistance	1,000 megohms min. between mutually isolated terminals
Dielectric Strength	Sea level: 350 VRMS/60 Hz
Diode P.I.V. 720D/722D	60 VDC, min.
Negative Coil Transient 720D/722D	2.0 Volt, max.

DETAILED ELECTRICAL SPECIFICATIONS (@ 25°C) (NOTE 2)

	GENERIC PART NUMBERS	720/722-5	720/722-6	720/722-9	720/722-12	720/722-18	720/722-26
		720D/722D-5	720D/722D-6	720D/722D-9	720D/722D-12	720D/722D-18	720D/722D-26
Coil Voltage (VDC)	Nom.	5.0	6.0	9.0	12.0	18.0	26.5
	Max.	6.0	8.0	12.0	16.0	24.0	32.0
Coil Resistance (Ohms \pm 10% @ 25°C)		61	120	280	500	1130	2000
Set & Reset Voltage (VDC, Max.) Pulse Operated		3.5	4.5	6.8	9.0	13.5	18.0

PERFORMANCE CURVES (NOTE 1)

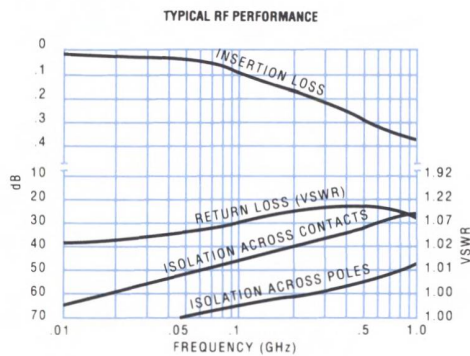

FIGURE 1

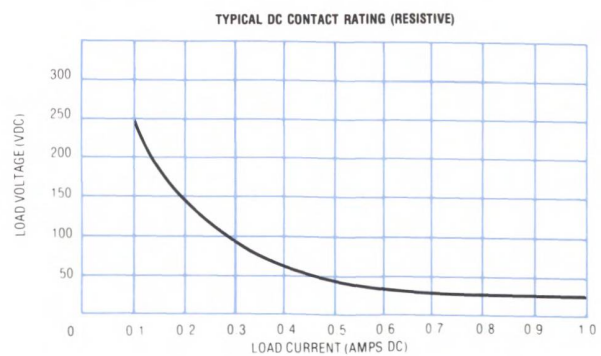
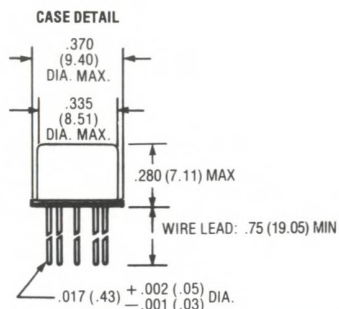
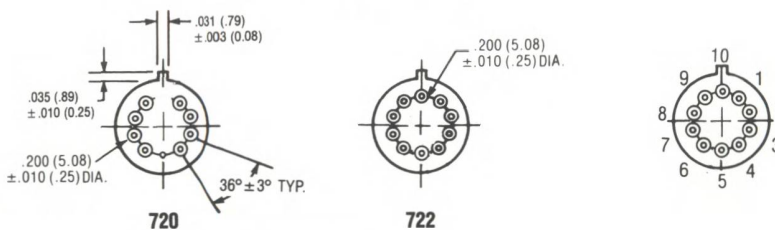

FIGURE 2

OUTLINE DIMENSIONS



TERMINAL LOCATIONS AND PIN NUMBERING (REF. ONLY)
(Viewed from Terminals)



DIMENSIONS ARE SHOWN IN INCHES (MILLIMETERS)

SPREADER PADS

Relays can be supplied with the 192-10 spreader pad installed and cemented in place. To order, add M to the part number (e.g., 722M-26).

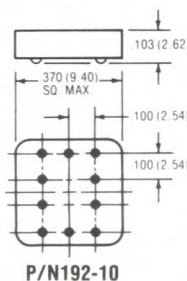

- NOTES:**
1. Material: Diallyl Phthalate
 2. Add 0.025 ohm to contact resistance with pad.
 3. Leads exit from holes indicated.
 4. Tolerance: .XXX = ±.010 (0.26).

SCHEMATIC DIAGRAMS

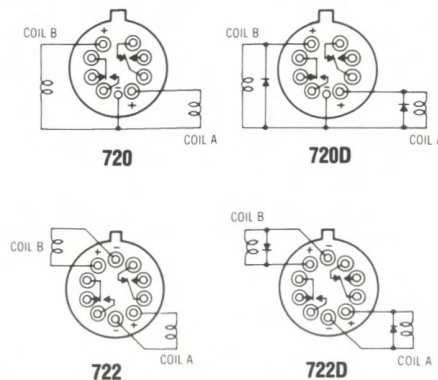

SCHEMATICS ARE VIEWED FROM TERMINALS. CONTACTS SHOWN IN POSITION RESULTING WHEN COIL A LAST ENERGIZED.

NOTES

1. Characteristics shown as "typical" are based on available data and are best estimates. No on-going verification tests are performed.
2. Characteristics are subject to change after life.
3. Relays will exhibit no contact chatter in excess of 10 μsec or transfer in excess of 1 μsec.

TELEDYNE RELAYS

COMMERCIAL CENTIGRID® MAGNETIC LATCHING R.F. RELAYS

SERIES RF170



DESCRIPTION

The RF170 Series relay is an ultraminiature, hermetically sealed, magnetic-latching relay featuring extremely low intercontact capacitance for exceptional R.F. performance over the full UHF spectrum. Its low profile height and .100" grid spaced terminals (precluding the need for spreader pads) make it ideal for applications where extreme packaging density and/or close PC board spacing are required.

The basic design and internal structure are similar to the T0-5 421 Series relay. In addition, the RF170 design has been optimized for use in RF attenuators, RF switch matrices, and other applications requiring high isolation, low insertion loss, and low VSWR.

Unique construction features and manufacturing techniques provide overall high reliability and excellent resistance to environmental extremes:

- All welded construction.
- Unique uni-frame design providing high magnetic efficiency and mechanical rigidity.
- High force/mass ratios to withstand shock and vibration.
- Advanced cleaning and sealing techniques provide maximum assurance of internal cleanliness.
- Gold plated precious metal alloy contacts ensure reliable d.c. switching from dry-circuit to 1/2 amp, as well as low, stable insertion loss.

The RF170 relay is ideally suited for applications where power dissipation must be minimized. The relays can be operated with a short-duration pulse. After the contacts have transferred, no holding power is required.

The magnetic-latching feature of the RF170 Series provides a "memory" capability, since the relays will not reset upon removal of coil power.

PRINCIPLE OF OPERATION

Energizing Coil B produces a magnetic field opposing the holding flux of the permanent magnet in Circuit B. As this net holding force decreases, the attractive force in the air gap of Circuit A, which also results from the flux of the permanent magnet, becomes great enough to break the armature free of Core B, and snap it into a closed position against Core A. The armature then remains in this position upon removal of power from Coil B, but will snap back to position B upon energizing Coil A. Since operation depends upon cancellation of a magnetic field, it is necessary to apply the correct polarity to the relay coils as indicated on the relay schematic.

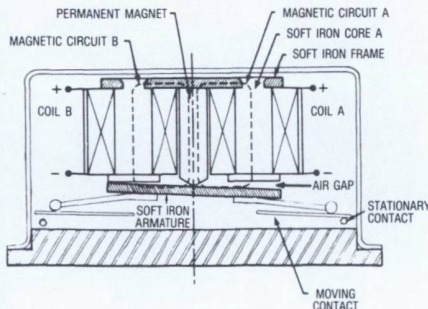

When latching relays are installed in equipment, the latch and reset coils should not be pulsed simultaneously. Coils should not be pulsed with less than the nominal coil voltage and the pulse width should be a minimum of three times the specified operate time of the relay. If these conditions are not followed, it is possible for the relay to be in the magnetically neutral position.

ENVIRONMENTAL AND PHYSICAL SPECIFICATIONS

Temperature (Ambient)	-55°C to +85°C
Vibration	10 g's to 1000 Hz (Note 3)
Shock	30 g's for 6 msec. (Note 3)
Enclosure	All welded, hermetically sealed
Weight	0.10 oz. (2.9 gms.) max.

GENERAL ELECTRICAL SPECIFICATIONS (@ 25°C) (NOTES 1 AND 2)

Contact Arrangement	2 Form C (DPDT)
Rated Duty	Continuous
Contact Resistance	0.15 ohm max. before life; 0.25 ohm max. after life at 0.5A/28VDC, (measured 1/8" from header)
Contact Load Rating (DC)	Resistive: 0.5 Amp/28VDC Inductive: 100 mA/28VDC (320 mH) Lamp: 50 mA/28VDC Low Level: 10 to 50 μ A/10 to 50 mV
Contact Life Ratings	10,000,000 cycles (typical) at low level 100,000 cycles min. at all other loads specified above
Contact Overload Rating	1 A/28VDC Resistive (100 cycles min.)
Contact Carry Rating	Contact factory
Coil Operating Power	290 milliwatts typical at nominal rated voltage
Operate Time	2.0 msec. max. at nominal rated coil voltage
Minimum Operate Pulse	6.0 msec. at nominal voltage
Intercontact Capacitance	0.02 pF. typical
Insulation Resistance	1,000 megohms min. between mutually isolated terminals
Dielectric Strength	Sea level: 350 VRMS/60 Hz

DETAILED ELECTRICAL SPECIFICATIONS (@ 25°C) (NOTE 2)

GENERIC PART NUMBERS		RF170-5	RF170-6	RF170-9	RF170-12	RF170-18	RF170-26
Coil Voltage (VDC)	Nom.	5.0	6.0	9.0	12.0	18.0	26.5
	Max.	6.0	8.0	12.0	16.0	24.0	32.0
Coil Resistance (Ohms \pm 20%)		61	120	280	500	1130	2000
Set & Reset Voltage (VDC, Max.)		3.5	4.5	6.8	9.0	13.5	18.0

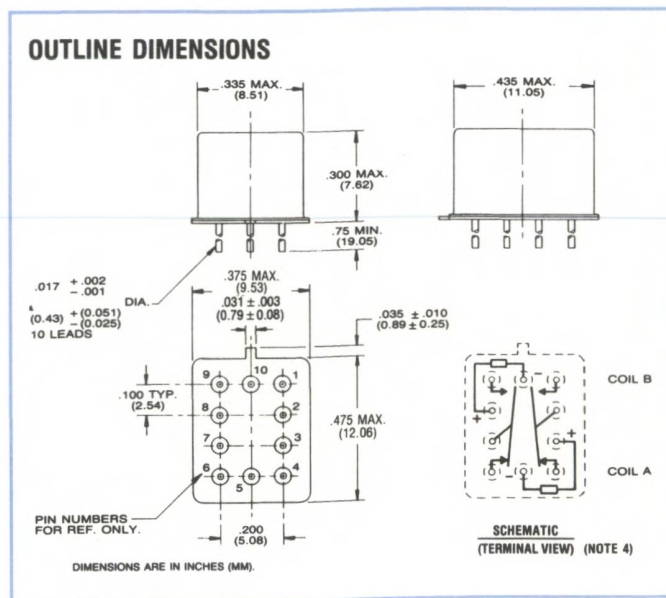
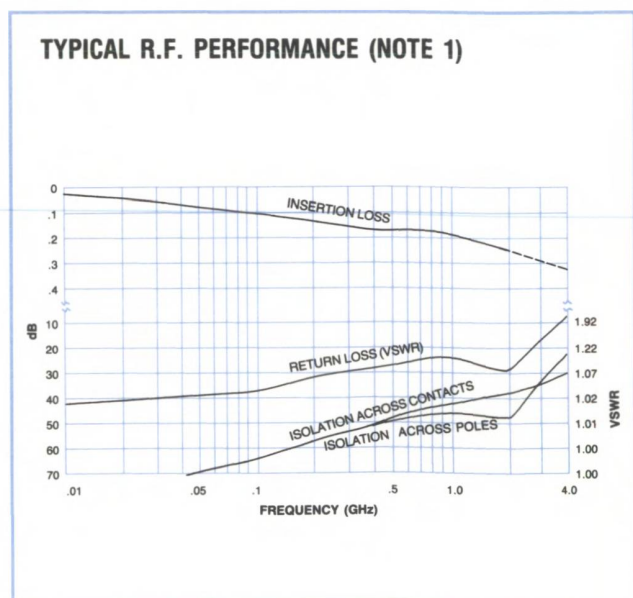

NOTES

1. Characteristics shown as "typical" are based on available data and are best estimates. No on-going verification tests are performed.
2. Characteristics are subject to change after life.
3. Relays will exhibit no contact chatter in excess of 10 μ sec or transfer in excess of 1 μ sec.
4. Contacts shown in position resulting when coil A last energized.

SECTION IV

APPENDIX

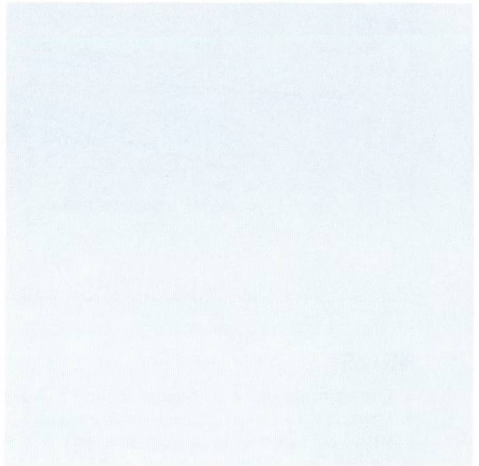
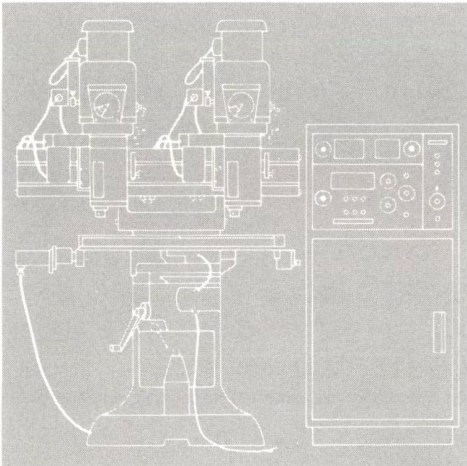
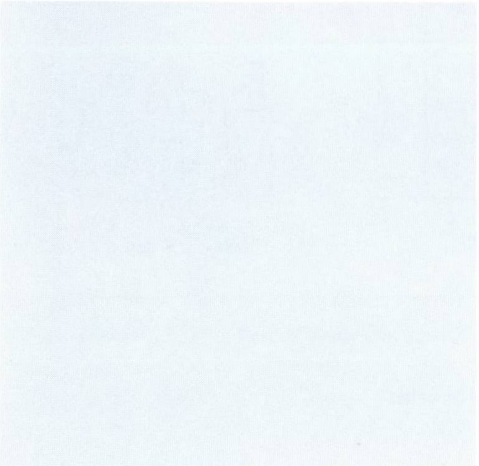
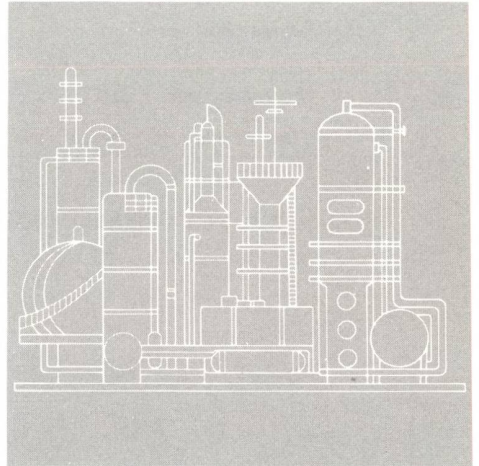
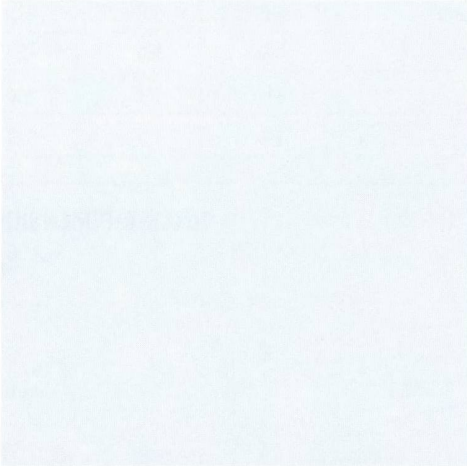
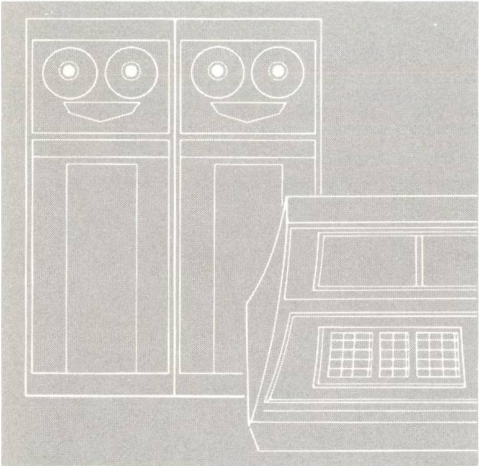
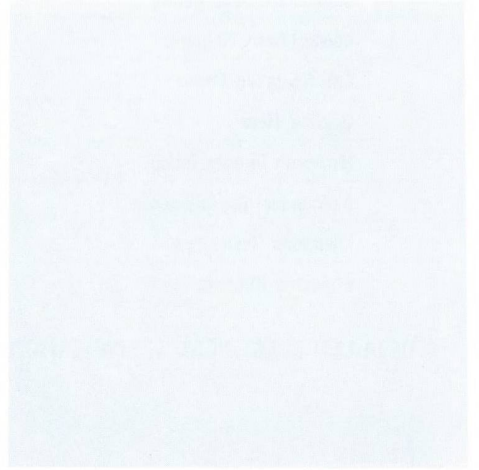
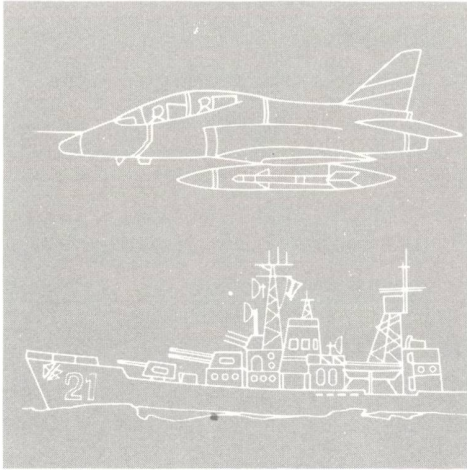
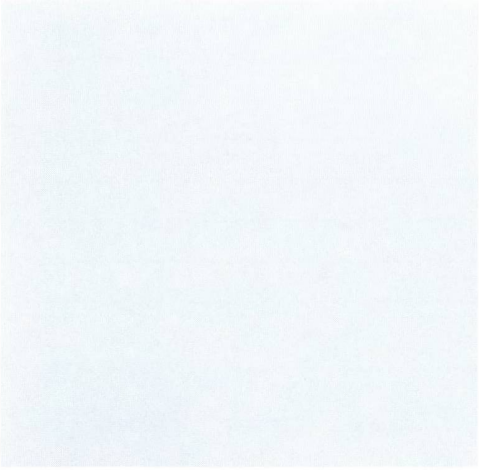

REGIONAL OFFICES

EASTERN REGIONAL OFFICE

Teledyne Relays
Cleveland Plaza
123 N. Union Avenue
Suite 306
Cranford, New Jersey 07016
(908) 272-0020
Easylink 62023363
FAX 908-272-7735

SOUTHEAST DISTRICT SALES OFFICE

Teledyne Relays
900 Fox Valley
Suite 206
Longwood, Florida 32779
(407) 682-9044
Easylink 62012265
FAX 407-682-7644

FACTORY SALES OFFICE

Teledyne Relays
12525 Daphne Avenue
Hawthorne, California 90250
(213) 777-0077
TWX 910-321-4610
Easylink 62952635
FAX 213-779-9161

WESTERN REGIONAL OFFICE

Teledyne Relays
5369 Camden Avenue
Suite 270
San Jose, California 95124
(408) 978-8899
FAX 408-978-8911

CENTRAL REGIONAL OFFICE

Teledyne Relays
11325 Pegasus Street
Suite W-201
Dallas, Texas 75238
(214) 348-0898
FAX 214-348-0915

NORTH CENTRAL DISTRICT SALES OFFICE

Teledyne Relays
290 Springfield Road
Suite 155
Bloomington, Illinois 60108
(708) 529-1060
Easylink 62023368
FAX 708-529-1120

REPRESENTATIVES

ALABAMA, MISSISSIPPI, WEST TENNESSEE

Elcom
4960 Corporate Drive
Suite 145K
Huntsville, Alabama 35805
(205) 830-4001
FAX 205-830-4058

ARIZONA, SO. NEVADA

Arcom Sales
7509 E. First Street
Scottsdale, Arizona 85251
(602) 947-5745
FAX 602-990-1765

ARKANSAS - See Texas

CALIFORNIA (SOUTHERN)

Teledyne Relays
12525 Daphne Avenue
Hawthorne, California 90250
(213) 777-0077
TWX 910-321-4610
Easylink 62952635
FAX 213-779-9161

CALIFORNIA (NORTHERN)

Teledyne Relays
5369 Camden Avenue
Suite 270
San Jose, California 95124
(408) 978-8899
FAX 408-978-8911

CANADA

Deskin Sales East (Montreal)
5656 Thimens Boulevard
St. Laurent, P.Q. H4R 2K9
Canada
(514) 331-2860
FAX 514-331-8692

Deskin Sales

105 Rocky Lake Drive
Unit 3
Bedford, Nova Scotia B4A 2T3
Canada
(902) 835-1166
FAX 902-835-1202

Deskin Sales

6 Antares Drive
Suite 204
Nepean, Ontario K2E 8A9
Canada
(613) 228-1201
FAX 613-228-1499

Deskin Sales

3520 78th Avenue
Edmonton, Alberta T6B 2X9
Canada
(403) 466-2106
FAX 403-468-3019

Deskin Sales

P.O. Box 173
Transcona, Manitoba R2C 2Z9
Canada
(204) 224-1321
FAX 204-224-2084

Deskin Sales

609 - 14th Street, N.W.
Suite 502
Calgary, Alberta T2N 2A1
Canada
(403) 270-4440
FAX 403-283-2491

Deskin Sales East

155 Clayton Drive
Markham, Ontario L3R 7P3
Canada
(416) 475-1412
FAX 416-474-9105

Deskin Sales West

8650 Cambie Street
Vancouver, B.C. V6P 6M6
Canada
(604) 324-8343
FAX 604-324-6965

COLORADO, WYOMING, MONTANA, IDAHO

Thorson Rocky Mountain
384 Inverness Drive South
Suite 201
Englewood, Colorado 80112
(303) 799-3435
FAX 303-799-3441

CONNECTICUT

VISTAssociates, Inc.
2505 Main Street
Stratford, Connecticut 06497
(203) 375-5456
TWX 710-453-1945
FAX 203-375-6907

DELAWARE - See Pennsylvania

DISTRICT OF COLUMBIA - See Maryland

FLORIDA

Teledyne Relays
900 Fox Valley Drive
Suite 206
Longwood, Florida 32779
(407) 682-9044
Easylink 62012265
FAX 407-682-7644

HHP Associates, Inc.

1177 Louisiana Avenue
Suite 209
Winter Park, Florida 32789
(407) 740-0320
FAX 407-740-0319

GEORGIA, EAST TENNESSEE

Elcom
4045 Wetherburn Way
Suite 5
Norcross, Georgia 30092
(404) 447-8200
FAX 404-447-8340

IDAHO - See Colorado

ILLINOIS (NORTHERN), WISCONSIN

Teledyne Relays
290 Springfield Road
Suite 155
Bloomington, Illinois 60108
(708) 529-1060
Easylink 62023368
FAX 708-529-1120

ILLINOIS (SOUTHERN), MISSOURI (EASTERN)

Rothkopf & Associates, Inc.
8721 Manchester Road
St. Louis, Missouri 63144
(314) 961-4485
FAX 314-961-4736

INDIANA

Leslie M. Devoe Company
4371 East 82nd Street
Suite D
Indianapolis, Indiana 46250
(317) 842-3245
FAX 317-845-8440

REPRESENTATIVES (CONTINUED)

IOWA

Stan Clothier Company
1930 St. Andrews N.E.
Cedar Rapids, Iowa 52402
(319) 393-1576
FAX 319-393-7317

KANSAS, NEBRASKA, MISSOURI (WESTERN)

Stan Clothier Company
815 Clairborne
Suite 275C
Olathe, Kansas 66062
(913) 829-0073
FAX 913-829-0429

KENTUCKY - See Ohio

LOUISIANA - See Texas

MARYLAND, DISTRICT OF COLUMBIA

Arbotek Associates, Inc.
102 West Joppa Road
Towson, Maryland 21204
(410) 825-0775
FAX 410-337-2781

MASSACHUSETTS

VISTAssociates, Inc.
237 Cedar Hill Street
P.O. Box 388
Marlborough, Massachusetts 01752
(508) 481-9277
TWX 710-380-0466
FAX 508-460-1869

MICHIGAN (NORTHERN) - See Illinois

MINNESOTA, NORTH & SOUTH DAKOTA

Stan Clothier Company
9600 West 76th Street
Suite A
Eden Prairie, Minnesota 55344
(612) 944-3456
FAX 612-944-6904

MISSISSIPPI - See Alabama

MISSOURI (EASTERN) - See Illinois (Southern)

MISSOURI (EASTERN) - See Illinois (Southern)

MISSOURI (WESTERN) - See Kansas

MONTANA - See Colorado

NEBRASKA - See Kansas

NEVADA (SOUTHERN) - See Arizona

NEVADA (NORTHERN) - See California (Northern)

NEW JERSEY (NORTH) - See New York (Metropolitan)

NEW JERSEY (SOUTH) - See Pennsylvania (Eastern)

NEW MEXICO

Reptronix
237 Eubank N.E.
Suite C
Albuquerque, New Mexico 87123
(505) 292-1718
FAX 505-299-1611

NEW YORK (Metropolitan), NO. JERSEY

Friedman-Smith Electronics
519 South Fifth Avenue
Mount Vernon, New York 10550
(914) 664-4866
FAX 914-664-4928

NEW YORK (Upstate)

Hotze & Murcan Associates
2500 Brewerton Road
Syracuse, New York 13211
(315) 455-8807
FAX 315-455-8810

NORTH & SOUTH CAROLINA

Elcom
7 Fox Lair Court
Asheville, North Carolina 28805
(704) 298-8709
FAX 404-447-8340

NORTH & SOUTH DAKOTA - See Minnesota

OHIO, KENTUCKY

J.C. Hofstetter Company
5244 Springboro Road
Dayton, Ohio 45439
(513) 296-1010
FAX 513-296-1274

J.C. Hofstetter Company
7014 River Styx Road
Medina, Ohio 44256
(216) 241-4880
FAX 216-725-4471

OKLAHOMA - See Texas

OREGON - See Washington

PENNSYLVANIA (WESTERN)

J.C. Hofstetter Company
P.O. Box 101
Hickory, Pennsylvania 15340
(412) 356-2305
FAX 412-356-7303

PENNSYLVANIA (EASTERN), SO. JERSEY, DELAWARE

Vantage Sales Company
V-105 Executive Mews
1930 East Marlton Pike
Cherry Hill, New Jersey 08003
(609) 424-6777
FAX 609-424-8909

TENNESSEE - See Alabama

TEXAS, ARKANSAS, OKLAHOMA, LOUISIANA

Kruvand Associates, Inc.
11754 Jollyville Road
Suite 109
Austin, Texas 78759
(512) 219-9441
FAX 512-219-1932

Kruvand Associates, Inc.
13405 Floyd Circle
Suite 112
Dallas, Texas 75243
(214) 437-3355
FAX 214-680-8854

UTAH

Thorson Rocky Mountain
1831 E. Fort Union Blvd.
Suite 103
Salt Lake City, Utah 84121
(801) 942-1683
FAX 801-942-1694

VIRGINIA - See Maryland

WASHINGTON

Tekrep Electronics
5500 Olympic Drive
Suite 105-407
Gig Harbor, Washington 98335
(206) 884-5050
FAX 206-884-3170

WISCONSIN - See Illinois

WYOMING - See Colorado

DOMESTIC DISTRIBUTORS

ALABAMA

Pioneer / Alabama
4825 University Square
Huntsville, Alabama 35816
(205) 837-9300
FAX 205-837-9358

Time Electronics
4801 University Square, Suite 15
Huntsville, Alabama 35816
(205) 721-1133

ARIZONA

Time Electronics
1301 West Geneva Drive
Tempe, Arizona 85282
(602) 967-2000
FAX 602-967-5923

CALIFORNIA

Milgray / Los Angeles
912 Pancho Road, Suite C
Camarillo, California 93012-8508
(805) 484-4055
FAX 805-388-8169

Milgray / Orange County
16 Technology Dr., Suite 206
Irvine, California 92718-2329
(714) 753-1282
FAX 714-753-1682

Milgray / San Jose
2860 Zanker Road, Suite 209
San Jose, California 95134
(408) 456-0900
FAX 408-456-0300

Time Electronics
3002 Dow Avenue, Suite 102
Tustin, California 92680
(714) 669-0100
FAX 714-544-2526

Time Electronics
9751 Independence Avenue
Chatsworth, California 91311
(818) 998-7200
FAX 818-998-0143

Time Electronics
1339 Moffet Park Drive
Sunnyvale, California 94089
(408) 734-9888
FAX 408-734-1719

Time Electronics
370 South Crenshaw Blvd., Suite E-104
Torrance, California 90503-1727
(213) 320-0880
FAX 213-320-6372

Time Electronics
9285 Dowdy Drive
San Diego, California 92126
(619) 586-0129
FAX 714-544-2526

CANADA

Deskin Sales
155 Clayton Drive
Markham, Ontario L3R 7P3
Canada
(416) 475-1412
FAX 416-474-9105

Deskin Sales
5656 Thimens Boulevard
St. Laurent, P.Q. H4R 2K9
Canada
(514) 331-2860
FAX 514-331-8692

Deskin Sales
8650 Cambie Street
Vancouver, B.C. V6P 6M6
Canada
(604) 324-8343
FAX 604-324-6965

Deskin Sales
P.O. Box 173
Transcona, Manitoba R2C 2Z9
Canada
(204) 224-1321
FAX 204-224-2084

Deskin Sales
6 Antares Drive, Suite 204
Nepean, Ontario K2E 8A9
Canada
(613) 228-1201
FAX 613-228-1499

Deskin Sales
3520 78th Avenue
Edmonton, Alberta T6B 2X9
Canada
(403) 466-2106
FAX 403-468-3019

Deskin Sales
105 Rocky Lake Drive, Unit 3
Bedford, Nova Scotia B4A 2T3
Canada
(902) 835-1166
FAX 902-835-1202

Deskin Sales
609 - 14th Street, N.W., Suite 502
Calgary, Alberta T2N 2A1
Canada
(403) 270-4440
FAX 403-283-2491

Milgray / Montreal
268 Lakeshore Road
Pointe Claire, Quebec H9S 4K9
Canada
(514) 426-5900
FAX 514-426-5836

Milgray / Toronto
150 Consumers Road, Suite 502
Willowdale, Ontario M2J 1P9
Canada
416-756-4481
FAX 416-756-2598

Time Electronics
2798 Thamesgate Drive, Unit 5
Mississauga, Ontario L4T 4E8
Canada
(416) 672-5300
FAX 416-672-5304

COLORADO

Time Electronics
7399 South Tucson Way, Suite A7
Englewood, Colorado 80112
(303) 799-8851
FAX 303-799-0012

CONNECTICUT

Milgray / Connecticut
Milford Plains Office Park
P.O. Box 418
Milford, Connecticut 06460-0418
(203) 878-5538
FAX 203-878-6970

Time Electronics
10A Centennial Drive
Peabody, Massachusetts 01960
(508) 532-9900
FAX 508-532-9989

Pioneer / Connecticut
112 Main Street
Norwalk, Connecticut 06851
(203) 853-1515
FAX 203-838-9901

Milgray / Florida
1850 Lee Road, Suite 104
Winter Park, Florida 32789-2199
(407) 647-5747
FAX 407-629-0757

Pioneer / Altamonte Springs
337 South-North Lake Blvd., Suite 1000
Altamonte Springs, Florida 32701
(407) 834-9090
FAX 407-834-0865

Pioneer / Clearwater
5500 Rio Vista Drive
Clearwater, Florida 34620
(813) 536-0445
FAX 813-531-5037

Pioneer / Deerfield Beach
674 South Military Trail
Deerfield Beach, Florida 33442
(305) 428-8877
FAX 305-481-2950

Time Electronics
5371 N.W. 33rd Avenue, Suite 210
Fort Lauderdale, Florida 33309
(305) 484-7778
FAX 305-484-7880

Time Electronics
4203 Vineland Road, Suite K7
Orlando, Florida 32811
(407) 841-6565
FAX 407-648-0814

GEORGIA

Electro-Air Corp.
2270 Marietta Blvd. N.W.
Atlanta, Georgia 30318
(404) 351-3545
FAX 404-351-9081

Milgray / Atlanta
3000 Northwoods Pky., Suite 270
Norcross, Georgia 30071-1545
(404) 446-9777
FAX 404-446-1186

Pioneer / Duluth
4250-C Rivergreen Parkway
Duluth, Georgia 30136
(404) 623-1003
FAX 404-623-0665

Time Electronics
4045 Wetherburn Way, Suite 6
Norcross, Georgia 30071
(404) 368-0969
FAX 404-368-0970

ILLINOIS

Milgray / Chicago
Kennedy Corporate Center I
1530 E. Dundee Road, Suite 310
Palatine, Illinois 60067-8319
(708) 202-1900
FAX 708-202-1985

Pioneer / Chicago
2171 Executive Drive, Suite 200
Addison, Illinois 60101
(708) 495-9680
FAX 708-495-9831

DOMESTIC DISTRIBUTORS (CONTINUED)

Time Electronics
2000 Algonquin Road
Schaumburg, Illinois 60173
(708) 303-3000
FAX 708-303-3030

INDIANA

Pioneer/Indiana
9350 N. Priority Way W. Dr.
Indianapolis, Indiana 46240
(317) 573-0880
FAX 317-573-0979

KANSAS

Milgray/Kansas City
6400 Glenwood, Suite 313
Overland Park, Kansas 66202-4021
(913) 236-8800
FAX 913-384-6825

MARYLAND

Milgray/Washington
9801 Broken Land Parkway, Suite 103
Columbia, Maryland 21046-1144
(301) 621-8169
FAX 301-381-3066

Pioneer/Gaithersburg
9100 Gaither Road
Gaithersburg, Maryland 20877
(301) 921-0660
FAX 301-921-4255

Time Electronics
9051 Red Branch Road
Columbia, Maryland 21045
(301) 964-3090
FAX 301-964-9274

MASSACHUSETTS

Time Electronics
10A Centennial Drive
Peabody, Massachusetts 01960
(508) 532-9900
FAX 508-532-9989

Milgray/New England
Ballardvale Park
187 Ballardvale Street
Wilmington, Massachusetts
01887-1046
(508) 657-5900
FAX 508-658-7989

Pioneer/Massachusetts
44 Hartwell Avenue
Lexington, Massachusetts 02173
(617) 861-9200
FAX 617-863-1547

MICHIGAN

Pioneer/Michigan
13485 Stamford
Livonia, Michigan 48150
(313) 525-1800
FAX 313-427-3720

Pioneer/Western Michigan
4505 Broadmoor Avenue, S.E.
Grand Rapids, Michigan 49512
(616) 698-1800
FAX 616-698-1831

MINNESOTA

Pioneer/Twin Cities
7625 Golden Triangle Drive
Eden Prairie, Minnesota 55344
(612) 944-3355
FAX 612-944-3794

Time Electronics
7667 Cahill Road
Edina, Minnesota 55435
(612) 835-1250
FAX 612-835-2119

MISSOURI

Pioneer/St. Louis
2029 Woodland Parkway, #101
St. Louis, Missouri 63146
(314) 432-4350
FAX 314-432-4854

Time Electronics
319 Consort Drive
Manchester, Missouri 63011
(314) 391-6444
FAX 314-391-8603

NEW JERSEY

Milgray/New Jersey
3001 Greentree Exec. Campus, Suite 102
Parsippany, New Jersey 07054-1273
(201) 335-1766
FAX 201-335-2110

Milgray/Delaware Valley
9801 Greentree Exec. Campus, Suite C
Marlton, New Jersey 08053-1551
(609) 983-5010
FAX 609-985-1607

Pioneer/New Jersey
14A Madison Road
Fairfield, New Jersey 07006
(201) 575-3510
FAX 201-575-3454

Time Electronics
4B Eves Drive, Suite 500
Marlton, New Jersey 08053
(609) 596-6700
FAX 609-596-4555

NEW YORK (UPSTATE)

Milgray/Upstate New York
One Corporate Place, Suite 200
1170 Pittsford-Victor Road
Pittsford, New York 14534-3807
(716) 381-9700
FAX 716-381-9495

Pioneer/Binghamton
68 Corporate Drive
Binghamton, New York 13904
(607) 722-9300
FAX 607-722-9562

Pioneer/Rochester
840 Fairport Park
Fairport, New York 14450
(716) 381-7070
FAX 716-381-5955

Time Electronics
7010 Fly Road
East Syracuse, New York 13057
(315) 432-0355
FAX 315-432-8147

Summit Distributors, Inc.
916 Main Street
Buffalo, New York 14203
(716) 887-2800
FAX 716-887-2866

Summit Distributors, Inc.
292 Commerce Drive
Rochester, New York 14623
(716) 334-8110

NEW YORK (METROPOLITAN)

Milgray/New York
77 Schmitt Blvd.
Farmingdale, New York 11735-1410
(516) 391-3000
FAX 516-420-0685

Pioneer/Woodbury
60 Crossways Park West
Woodbury, New York 11797
(516) 921-8700
FAX 516-921-2143

Time Electronics
70 Marcus Blvd.
Hauppauge, New York 11788
(516) 273-0100
FAX 516-273-0037

NORTH CAROLINA

Milgray/Raleigh
2925 Huntleigh Drive, Suite 101
Raleigh, North Carolina 27604-3374
(919) 790-8094
FAX 919-872-8851

Pioneer/Charlotte
9401-L Southern Pine Blvd.
Charlotte, North Carolina 28217
(704) 527-8188
FAX 704-522-8564

Pioneer/Durham
2810 Meridian Parkway, Suite 148
Durham, North Carolina 27713
(919) 544-5400
FAX 919-544-5885

Time Electronics
6060-B Six Forks Road
Raleigh, North Carolina 27609
(919) 847-9650
FAX 919-847-0273

OHIO

Milgray/Cleveland
6155 Rockside Road, Bldg. 1, Suite 206
Cleveland, Ohio 44131-2289
(216) 447-1520
FAX 216-447-1761

Pioneer/Cleveland
4800 East 131st Street
Cleveland, Ohio 44105
(216) 587-3600
FAX 216-663-1004

Pioneer/Dayton
4433 Interpoint Blvd.
Dayton, Ohio 45424
(513) 236-9900
FAX 513-236-8133

Time Electronics
2580 Oakstone Drive, Suite A
Columbus, Ohio 43231
(614) 794-3301
FAX 614-794-3306

OREGON

Time Electronics
15688 S.W. 72nd Avenue
Portland, Oregon 97224
(503) 684-3780
FAX 503-684-3781

PENNSYLVANIA

Pioneer/Horsham
261 Gibraltar Road
Horsham, Pennsylvania 19044
(215) 674-4000
FAX 215-674-3107

Pioneer/Pittsburgh
259 Kappa Drive
Pittsburgh, Pennsylvania 15238
(412) 782-2300
FAX 412-963-8255

TEXAS

Milgray/Dallas
16610 Dallas Parkway, Suite 1300
Dallas, Texas 75248-2617
(214) 248-1603
FAX 214-248-0218

Pioneer/Austin
1826-D Kramer Lane
Austin, Texas 78758
(512) 835-4000
FAX 512-835-9829

Pioneer/Dallas
13765 Beta Road
Dallas, Texas 75244
(214) 386-7300
FAX 214-490-6419

Milgray/Houston
12919 SW Freeway, Suite 130
Stafford, Texas 77477-4113
(713) 240-5360
FAX 713-240-5404

Pioneer/Houston
10530 Rockley Road, Suite 100
Houston, Texas 77099
(713) 495-4700
FAX 713-495-5642

Time Electronics
9300 Jolleyville, Suite 100
Austin, Texas 78758
(512) 346-7346
FAX 512-346-7527

Time Electronics
1876 Firman Drive
Richardson, Texas 75081
(214) 644-4644
FAX 214-644-6668

UTAH

Milgray/Utah
4190 South Highland Dr., Suite 102
Salt Lake City, Utah 84124-2600
(801) 272-4999
FAX 801-272-7005

Time Electronics
1600 W 2200 South, Suite 100
West Valley, Utah 84119
(801) 973-8494
FAX 801-973-7418

WASHINGTON

Time Electronics
11511 N.E. 118th Street
Kirkland, Washington 98033
(206) 820-1525
FAX 206-820-1088

WISCONSIN

Pioneer/Wisconsin
120 Bishops Way, #163
Brookfield, Wisconsin 53005
(414) 784-3480
FAX 414-784-8207

INTERNATIONAL SALES REPRESENTATIVES

AUSTRALIA

VSI - Promark Electronics Pty, Ltd.
16 Dickson Avenue
Artarmon NSW, 2064
Australia
4398622
FAX 4396435

VSI - Promark Electronics Pty, Ltd.
Suite 3
366 Whitehorse Road
Nunawading, VIC. 3131
Australia
(03) 878-1255

Coherent Scientific Pty, Ltd.
138 Greenhill Road
Unley 5061
South Australia
(08) 271-4755
FAX 08-271-1202

AUSTRIA

Elra
Ruepgasse 11
A-1020 Vienna
Austria
(0043) 222/21417850
TLX 135507
FAX (0043) 222/263834

BELGIUM

Alcom Electronics b.v.b.a.
Singel 3
B-2550 Kontich
Belgium
(03) 458-3033
FAX 03-458-31-26

BRAZIL

Hitech Commercial E Industrial Ltda.
Av. Eng. Luiz Carlos Berrini, 801
11 Andar-Brooklin
04571 Sao Paulo, SP
Brazil
(55-11) 240-2650
TLX 11-53288

CANADA

Deskin Sales
155 Clayton Drive
Markham, Ontario L3R 7P3
Canada
(416) 475-1412
FAX 416-474-9105

Deskin Sales
5656 Thimens Boulevard
St. Laurent, P.Q. H4R 2K9
Canada
(514) 331-2860
TWX 610-421-3793
TLX 05-824-838
FAX 514-331-8692

Deskin Sales
6 Antares Drive
Suite 204
Nepean, Ontario K2E 8A9
Canada
(613) 228-1201
FAX 613-228-1499

Deskin Sales
8650 Cambie Street
Vancouver, B.C. V6P 6M6
Canada
(604) 324-8343
FAX 604-324-6965

Deskin Sales
3520 78th Avenue
Edmonton, Alberta T6B 2X9
Canada
(403) 466-2106
FAX 403-468-3019

Deskin Sales
P.O. Box 173
Transcona, Manitoba R2C 2Z9
Canada
(204) 224-1321
FAX 204-224-2084

Deskin Sales
105 Rocky Lake Drive
Unit 3
Bedford, Nova Scotia B4A 2T3
Canada
(902) 835-1166
FAX 902-835-1202

Deskin Sales
609 - 14th Street, N.W.
Suite 502
Calgary, Alberta T2N 2A1
Canada
(403) 270-4440
FAX 403-283-2491

DENMARK

Exatec A/S
Dortheavej 1-3
DK-2400 Copenhagen NV
Denmark
(0045) 31-191022
TLX 055-27253
FAX 0045-31-193120

FINLAND

Repicomp Oy
Tammisalontie 4
SF 00830 Helsinki
P.O. Box 58
SF 00931 Helsinki
Finland
(00358) 0-7557201
TLX 057
FAX 00358-0-788256

HONG KONG

Renful Tech. Ltd.
Room 2429-2432
Sun Hung Kai Centre
30 Harbour Road
Wanchai
Hong Kong
827-0500
FAX 827-1267

INDIA

Spectra Innovations Inc.
780 Montague Expressway
Suite 208
San Jose, California 95131-1316
U.S.A.
408-954-8474
FAX 408-954-8399
TLX 405746 SPECTRA SJ UD

Spectra Innovations Inc.
c/o Pernat United
24 Ferena, Colaba
Opp. Fariyas Hotel
Bombay - 400, 005
India
22-233-117 or 287-2220
FAX 022-287-2220 Attn: 1302
TLX 115-7922 NATU IN

Spectra Innovations Inc.
c/o Supra Technologies
Flat No. 52, IV B, II Floor
Bharani Complex
Sir Ronaldross Road
Secunderabad - 500003
India
0842-846-161
FAX 0842-842477
TLX 0425 6630 PCO IN

Spectra Innovations Inc.
c/o Spectel Technologies
1826-27 L.N. Street
Pahargunj, New Delhi - 110 055
India
011-526630
FAX 011-526630
TLX 0316-1273 NDI IN

Spectra Innovations Inc.
c/o Lavs International
G-2, Sudarshan Garden
102 Velachery Road
Guindy Madras 600 032
Tamil Nadu
India
044-235-1366
FAX 044-732-66
TLX 041-7598 INTR IN

Spectra Innovations Inc.
Manipal Centre
Unit No-S-822
47, Dickenson Rd. Off M.G. Road
Bangalore-560, 042
India
91-812-261468
FAX 91-812-261468 (IC FAX 217)
TLX 845-2696 PCO IN ICTP-705

ISRAEL

STG International Ltd.
7, Derech Hashalom
67892, Tel Aviv
Israel
972-326-5231
FAX 972-326-5141

ITALY

Mitec S.r.l. Technologie
E Componenti Elettronici
Via S. Gimignano, N 38
20146 Milano
Italy
(02) 48301939
TLX 322029 Mitec I
FAX 02-48301959

M2R S.r.l.
Prodotti E Technologie
Per L'Elettronica
Via Tiberina, 82
00188 Roma
Italy
(06) 3002898
FAX 06-6911221

KOREA

Hanaro Corporation
Hana Bldg. 122-30
Chungdam-Dong
Gangnam-Ku, Seoul
Korea 135-100
(02) 516-1144
FAX 02-516-1151
Easylink 62057328

INTERNATIONAL SALES REPRESENTATIVES (CONTINUED)

NETHERLANDS

Alcom Electronics BV
Postbus 358
Esse Baan 1
NL 2908 LJ Capelle A/D IJssel
Netherlands
(10) 4519533
TLX 26160
FAX 10-4586482

NEW ZEALAND

Professional Electronics Ltd.
P.O. Box 31143
Milford, Auckland
New Zealand
(64) 9-463-048
TLX AK290NZ
FAX 64-9-463-045

NORWAY

Nortec Electronics A/S
P.O. Box 123
Smedsvingen 4B
1364 Hvalstad
Norway
(02) 846210
TLX 77546
FAX 02-846545

PAKISTAN

S+D International
Cavish Court
A-35, Block 7 & 8, KCHSU
Shahrah-E-Faisal, Karachi-75350
Pakistan
442051-57/442068
TLX 25684
FAX 92-21-436777

PORTUGAL

Componenta Componentes
Electronicos, Ltda.
Rua Luis De Camoes, 128
1300 Lisboa
Portugal
(1) 3621283
TLX 61562
FAX 1-3637655

SCOTLAND

Aardvark Electronic Components
Pitreevie Business Park
Dunfermline, Fife KY11 5PU
United Kingdom
(0383) 620735
FAX 0383-620736

SINGAPORE

Device Electronics PTE, Ltd.
605B Mac Pherson Road, #04-12
Citimac Industrial Complex
Singapore 1336
2886455
FAX 2879197

SOUTH AFRICA

Agatronics Components (Pty, Ltd.)
P.O. Box 51518
Randburg 2125
South Africa
11-7891065
TLX 4-24159
FAX 8860344

SPAIN

Amitron Pasivos S.A.
Avda De Valladolid 47 D
28008 Madrid
Spain
(0034) 1-5420906
FAX 0034-1-5590809

SWEDEN

Egevo AB
P.O. Box 8100
Fagerstagatan 4
S-163 08 Spanga
Sweden
(8) 7959650
FAX 8-7957883

SWITZERLAND

Walter Blum AG
Tramstrasse 10
CH-8050 Zurich
Switzerland
4113126872
FAX 4113113048

TAIWAN

Micro Electronics Co.
11th Floor, 75 Sec.
3 Ming-Sheng E. Road
Taipei, Taiwan
Republic of China
886-2-5063320
FAX 886-2-5048081

International Distributors

CANADA - See Desk Sales above

Milgray / Toronto
150 Consumers Road, Suite 502
Willowdale, Ontario M2J 1P9
Canada
(416) 756-4481
FAX 416-756-2598

Milgray / Montreal
268 Lakeshore Road
Pointe Claire, Quebec H9S 4K9
Canada
(514) 426-5900
FAX 514-426-5836

Time Electronics
2798 Thamesgate Drive, Unit 5
Mississauga, Ontario L4T 4E8
Canada
(416) 672-5300
FAX 416-672-5304

ENGLAND

STC Electronic Services
Edinburgh Way, Harlow
Essex CM20 2DE
England
0279-626-777
TLX 818801

MCP Electronics Ltd.
City Gate House
399-425 Eastern Avenue
Grants Hill, Ilford
Essex IG2 6LR
England
081-518-2000
TLX 8954213
FAX 081-518-3222

FRANCE

Prodyne
Z.A.C. de Courtaboeuf
Technopolis Batiment Alpha
3, Avenue Du Canada
F-91966 Les Ulis Cedex B
France
(0033) 1-69283637
FAX (0033) 1-69282999

Tekelec Airtronic
Cite Des Bruyeres
Rue Carle Vernet
92310 Sevres
France
46-23-24-25
TLX 204552
FAX 45072191

GERMANY

Hot Electronic
Vertriebs GmbH
Postfach 1261
Wendelsteinweg 11
8028 Taufkirchen-Potzham
Germany
(089) 612-1092-96
TLX 529528
FAX 089-6128667

Hot Electronic
Vertriebes, Fuer
Bauelemente und Geraete mbH
Schulstr, 22
7060 Schorndorf
Germany
(071) 81-3093
TLX 7246622
FAX 21671

ITALY

Tekelec Airtronic S.P.A.
Via Mameli 31
20129 Milano
Italy
2-7380641
TLX 312402
FAX (0039) 2-73-85-462

PUERTO RICO

Milgray Electronics
Puerto Rico, Inc.
Calle No. 1 Carr #188
Urb. Ind./San Isidro
Canovanas 00629
Puerto Rico
(809) 876-8200
FAX 809-876-8285



12525 Daphne Avenue, Hawthorne, California 90250-3384 (213) 777-0077